

This catalog covers:

'09~'11 ER650 C9F/CAF/CBF

GRID NO.

A-1

This grid covers:

Title



PARTS CATALOG

'09~'11 ER650 C9F/CAF/CBF

(ER-6n)

Publications	A-2
Model Identification	A-4
Engine	B-1
Chassis	E-1

© Kawasaki Heavy Industries, Ltd. 2010

Engine No. Location:

Upper crankcase, front side

Year & Model

Color

'09 ER650C9F

1. KMT.Candy Burnt Orange (15T)
2. KMT.Metallic Diablo Black (15Q)
3. KMT.Pearl Stardust White (15S)

VIN No. Range

JKAER650CCDA00001 ~ A47086

Engine No. Range

ER650AEA00001 ~

'10 ER650CAF

1. Ebony (H8)
2. KMT.Pearl Blazing Orange (848)
3. Lime Green (777)

JKAER650CCDA47087 ~ A61492

ER650AEA00001 ~

'11 ER650CBF

1. KMT.Metallic Flat Sage Green (35A)
2. KMT.Metallic Spark Black (15Z)
3. KMT.Pearl White (G3)

JKAER650CCDA61493 ~

ER650AEA00001 ~

This catalog covers:

'09~'11 ER650 C9F/CAF/CBF

GRID NO.

A-2

This grid covers:

Publications

Year & Model	Owner's Manual	A&P Manual		Service Manual		Microfiche
		General	Supplement	Basic	Supplement	
2009 ER650C9F	99976-1426(EN/FR/DE) 99976-1427(IT/ES/NL) 99986-1450(English)	99931-1506-01		99924-1418-01		99912-1582-03
2010 ER650CAF	99976-1563(EN/FR/DE) 99976-1564(IT/ES/NL) 99986-1555(English)	See above		99924-1418-02		See above
2011 ER650CBF	99976-1580(EN/FR/DE) 99976-1581(IT/ES/NL) 99986-1577(English)	See above		99924-1418-03		See above

This catalog covers:

'09~'11 ER650 C9F/CAF/CBF

GRID NO.

A-4

This grid covers:

Model I.D. '09~'10 ER650 C9F/CAF

ER650C9F

Left Side View

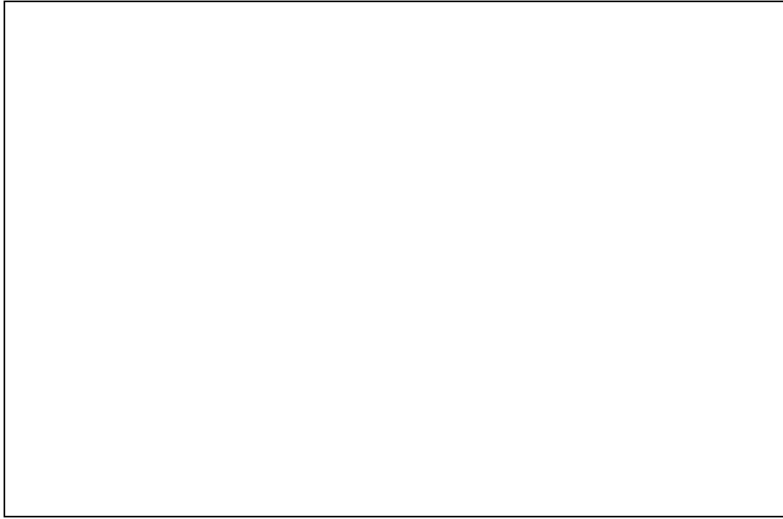

Right Side View



ER650CAF

Left Side View

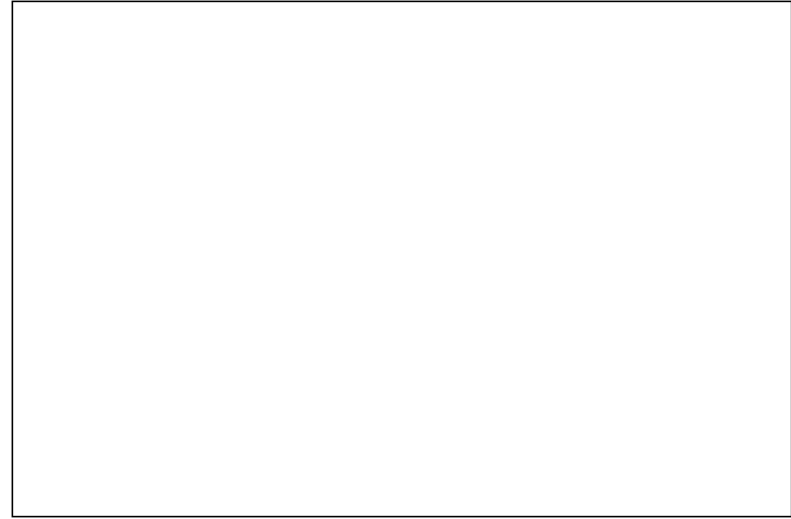

Right Side View



This catalog covers:

'09~'11 ER650 C9F/CAF/CBF

GRID NO.

A-5

This grid covers:

Model I.D. '11 ER650CBF

ER650CBF

Left Side View

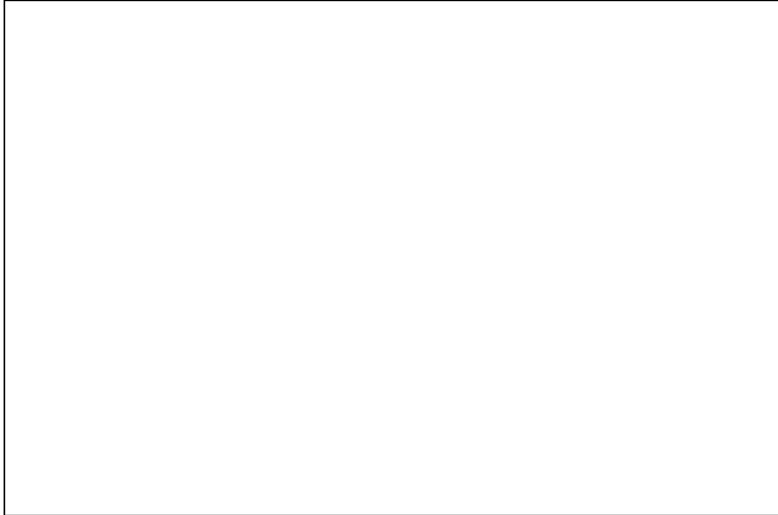

Right Side View

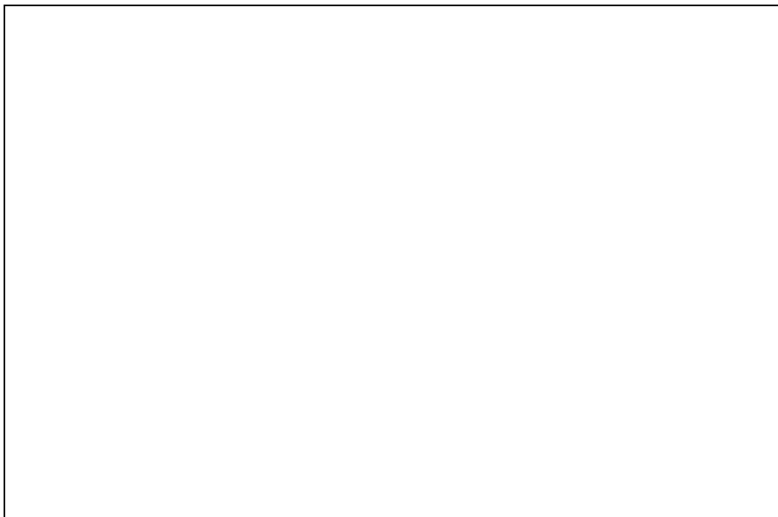

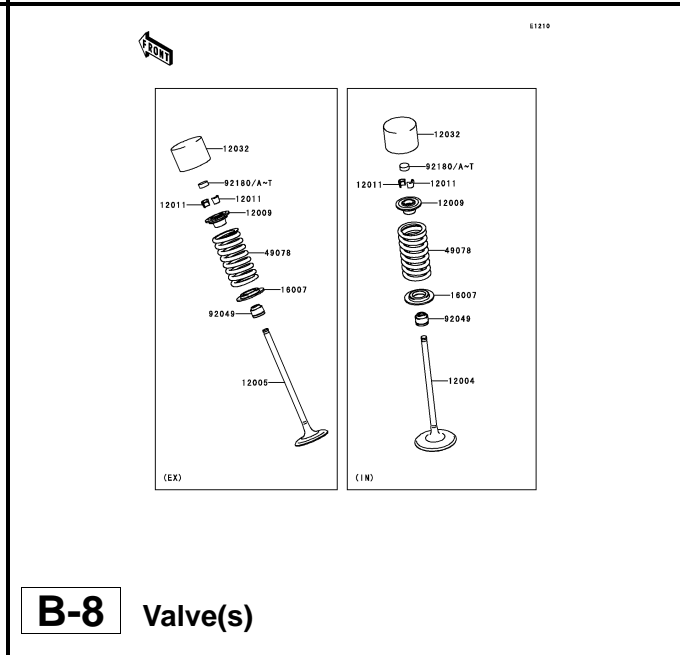
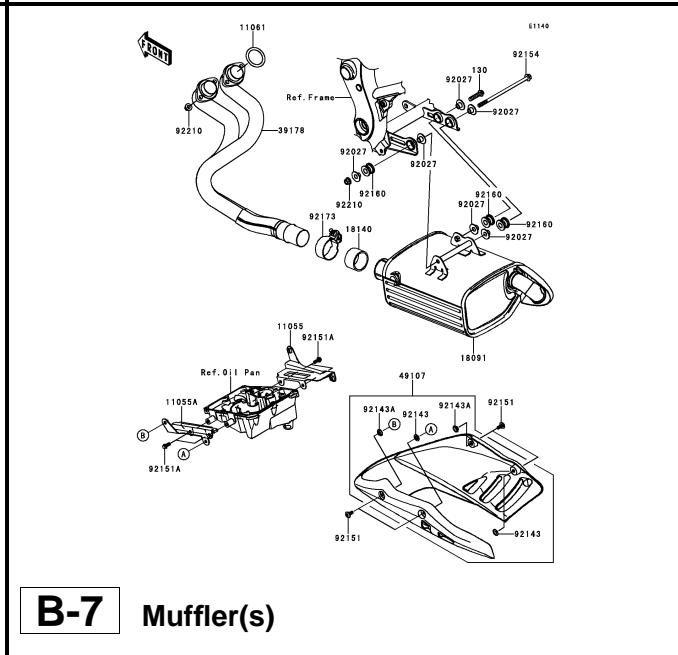
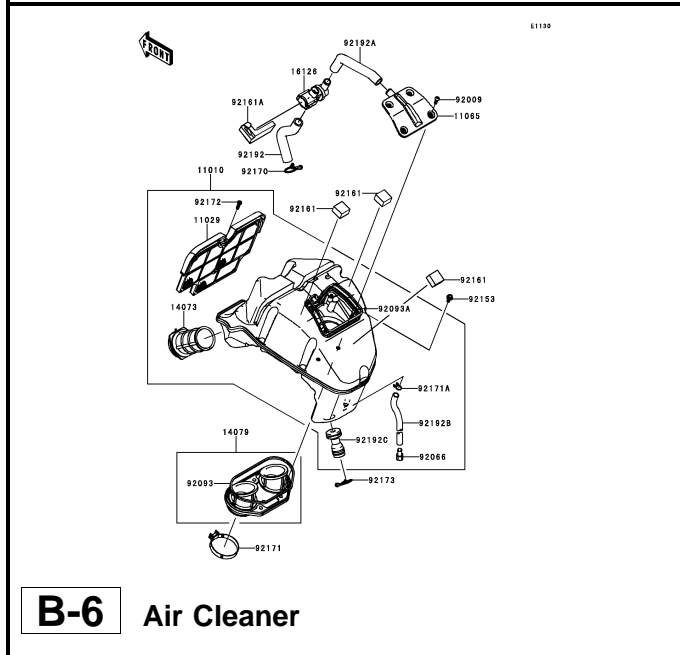
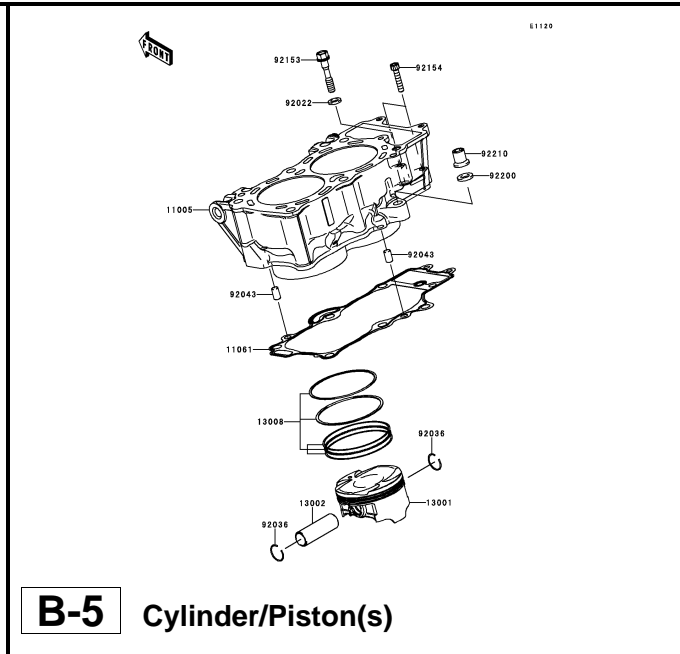
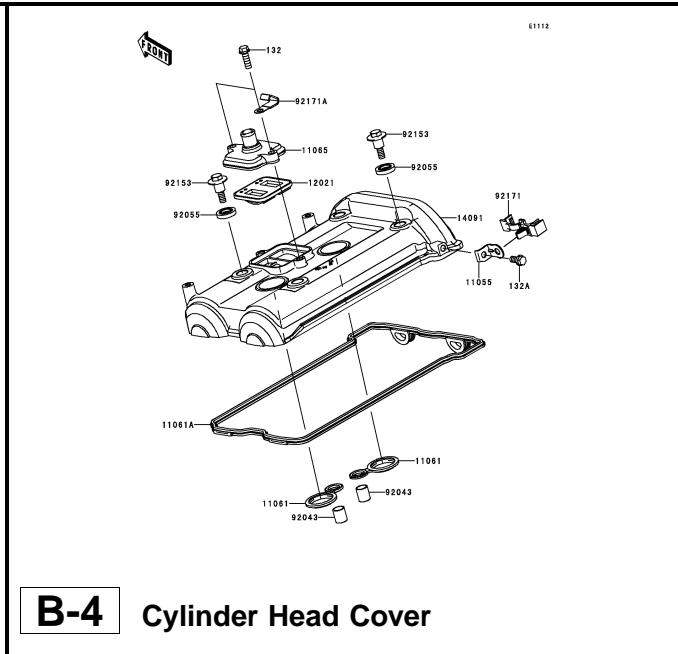
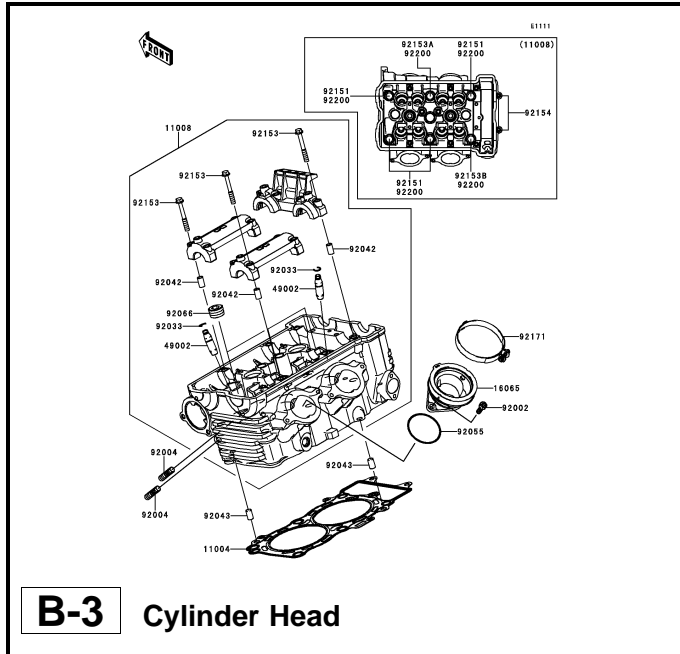

This catalog covers:

'09~'11 ER650 C9F/CAF/CBF Engine

GRID NO.

B-2

This grid covers:

Pictorial Index

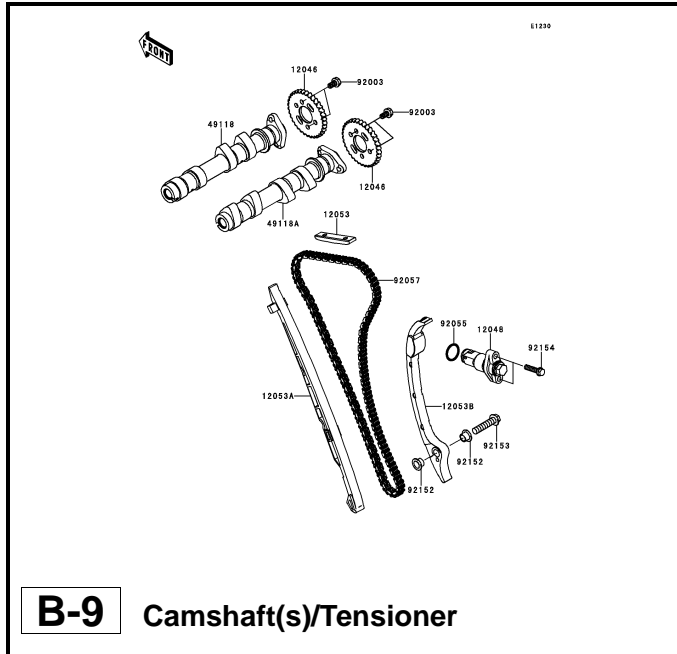

B-9 Camshaft(s)/Tensioner

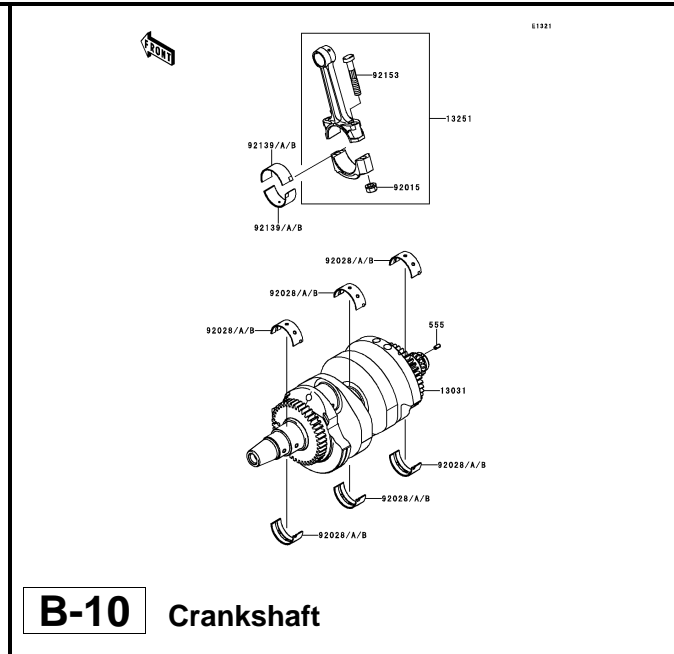

B-10 Crankshaft

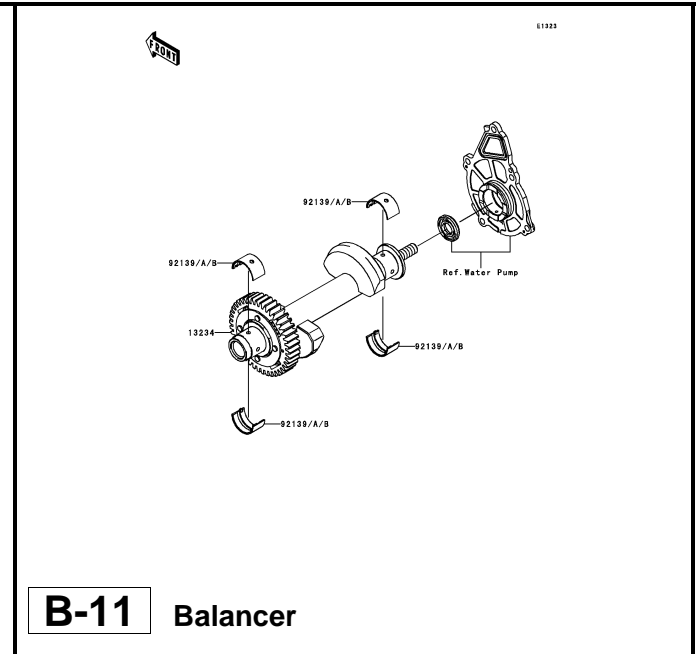

B-11 Balancer

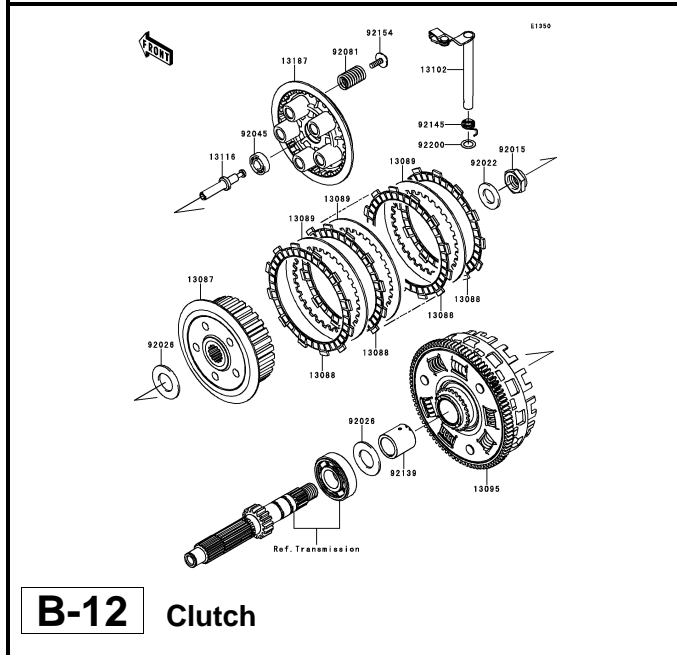

B-12 Clutch

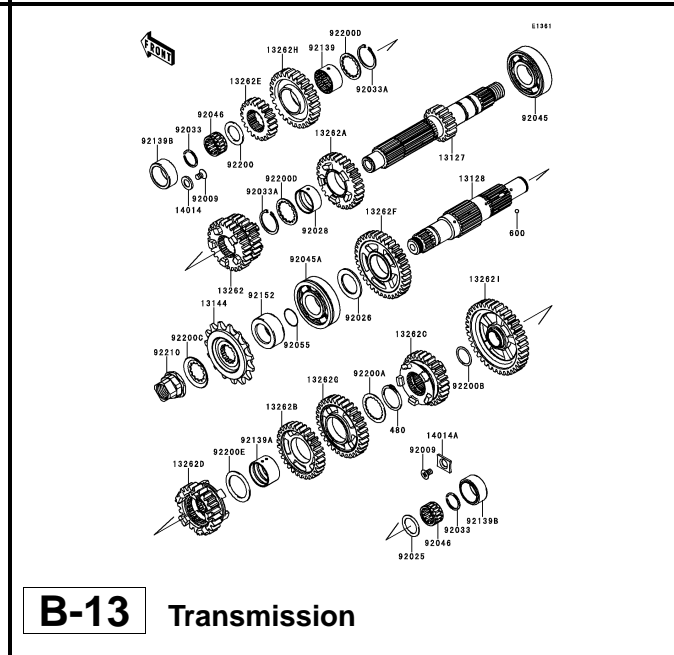

B-13 Transmission

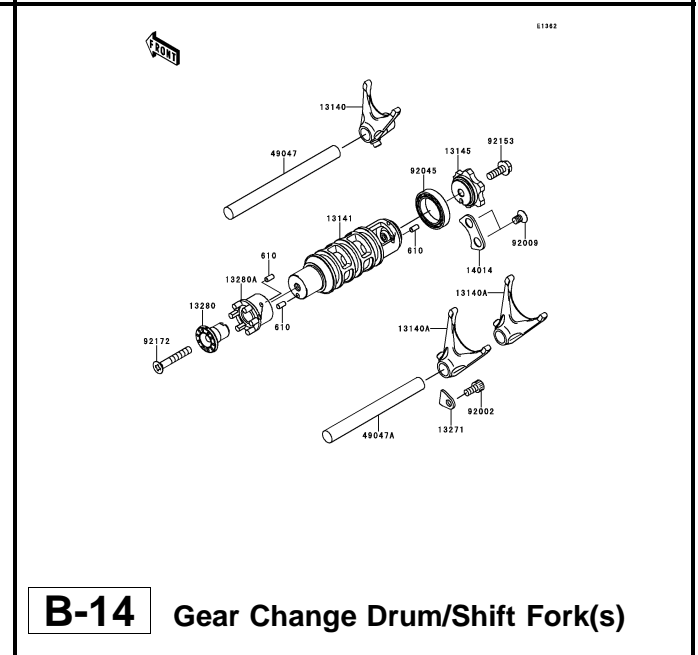

B-14 Gear Change Drum/Shift Fork(s)

This catalog covers:

'09~'11 ER650 C9F/CAF/CBF Engine

GRID NO.

C-1

This grid covers:

Pictorial Index

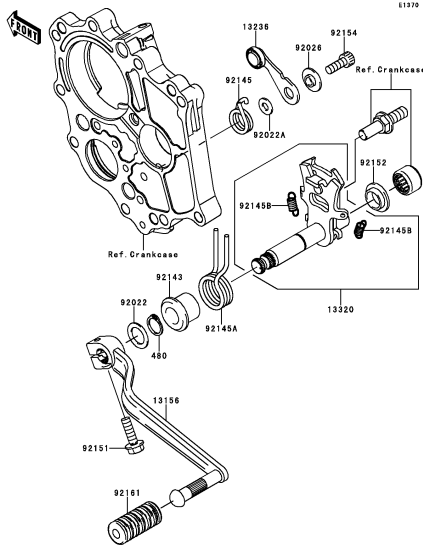

C-3 Gear Change Mechanism

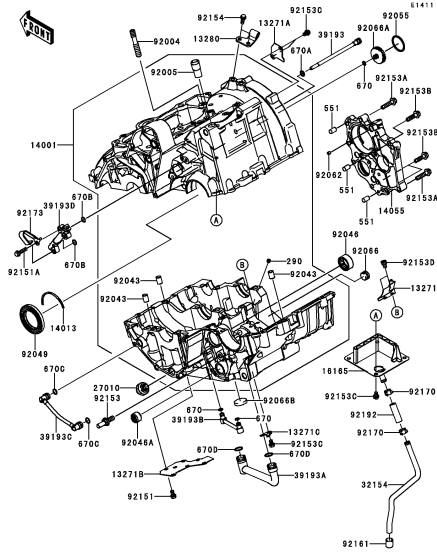

C-4 Crankcase(1/2)

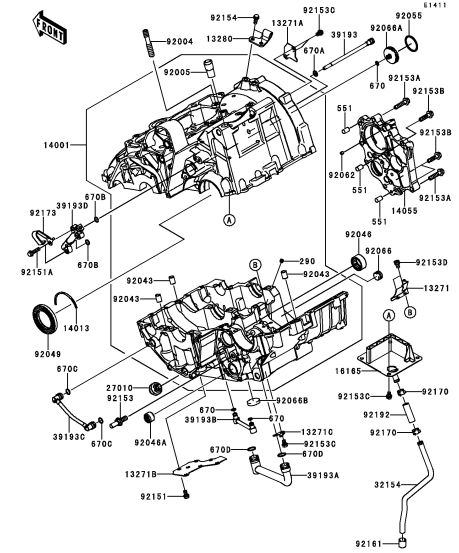

C-5 Crankcase(2/2)

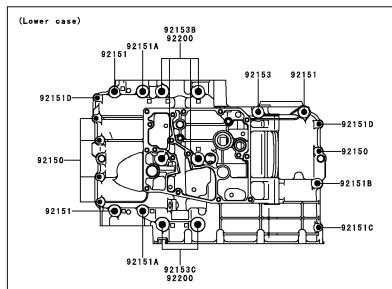
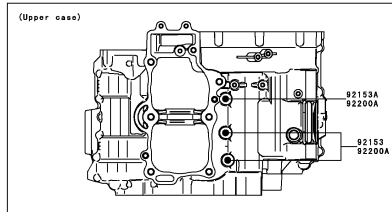

C-6 Crankcase Bolt Pattern

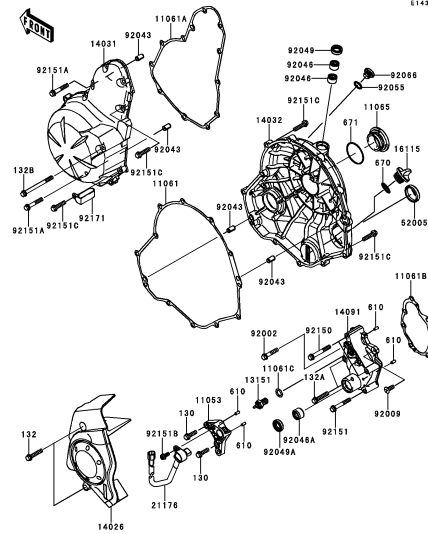

C-7 Engine Cover(s)

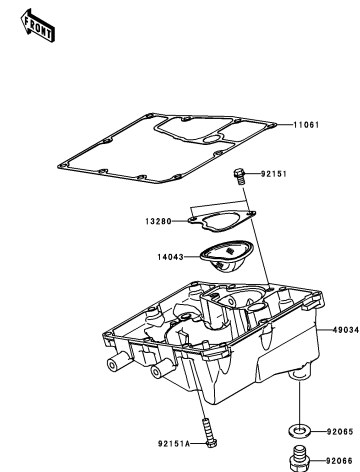

C-8 Oil Pan

This catalog covers:

'09~'11 ER650 C9F/CAF/CBF Engine

GRID NO.

C-2

This grid covers:

Pictorial Index

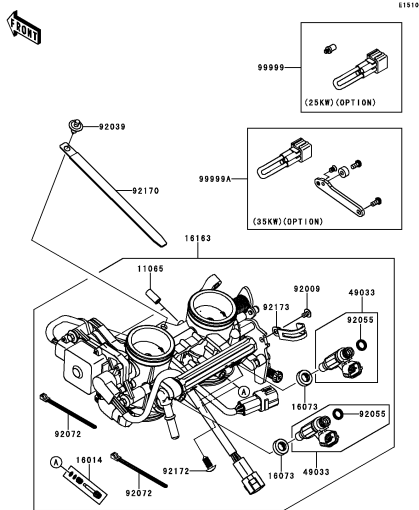

C-9 Throttle

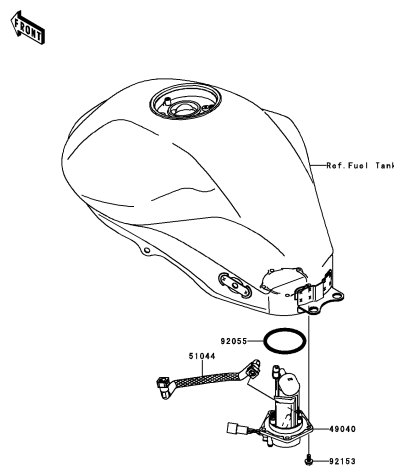

C-10 Fuel Pump

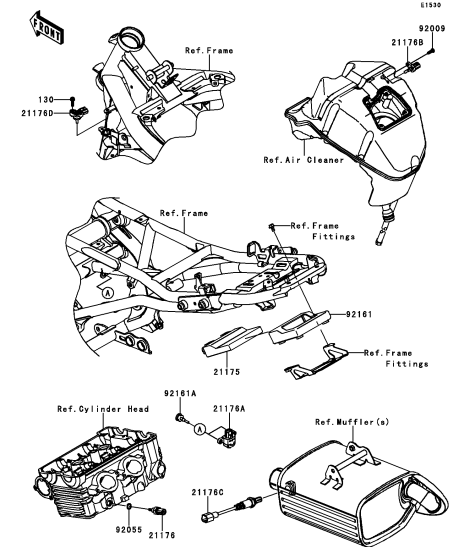

C-11 Fuel Injection

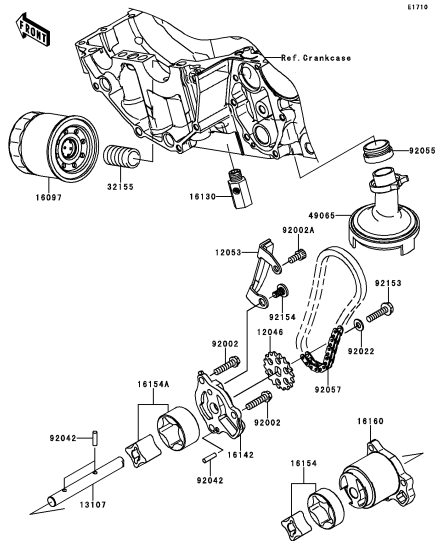

C-12 Oil Pump

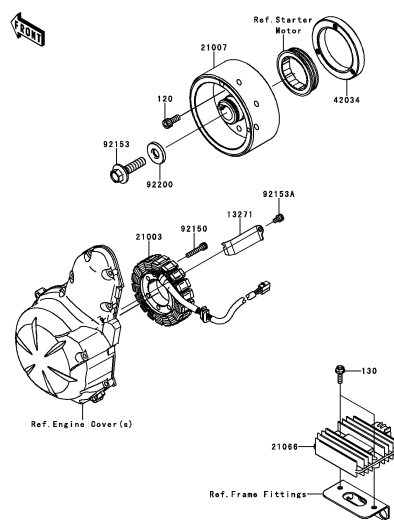

C-13 Generator

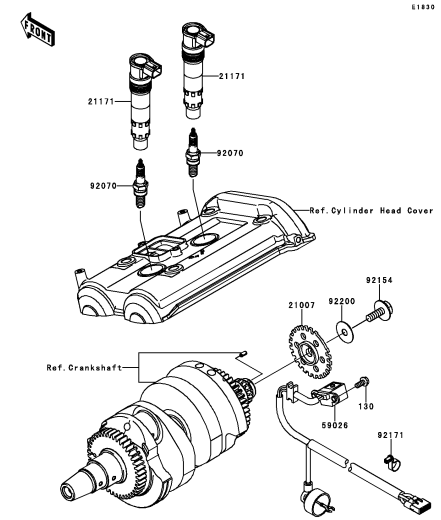

C-14 Ignition System

This catalog covers:

'09~'11 ER650 C9F/CAF/CBF Engine

GRID NO.

D-1

This grid covers:

Pictorial Index

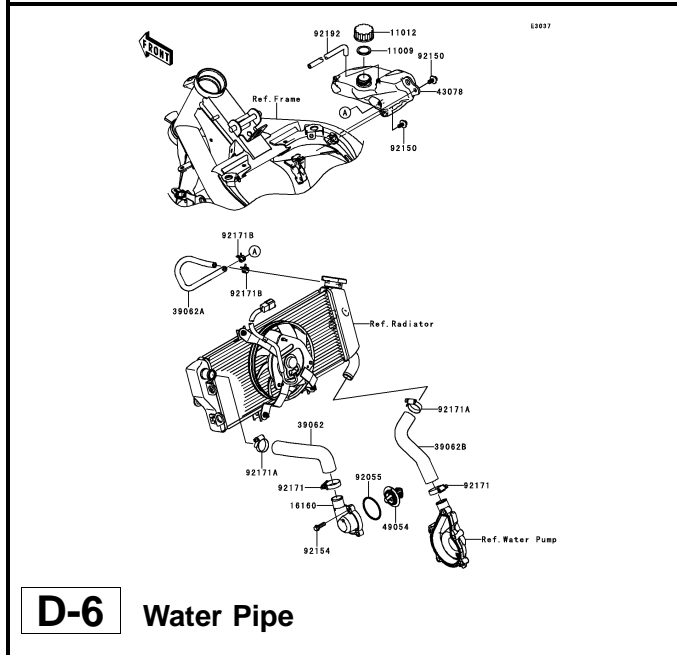
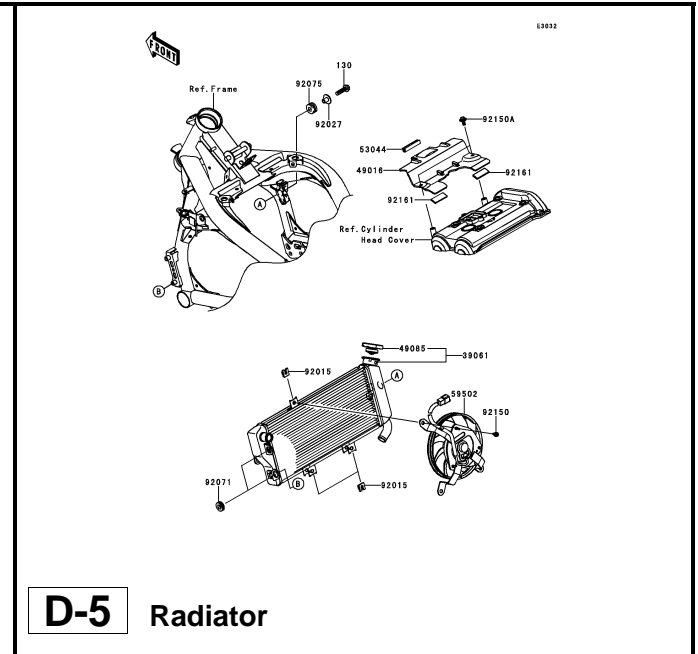
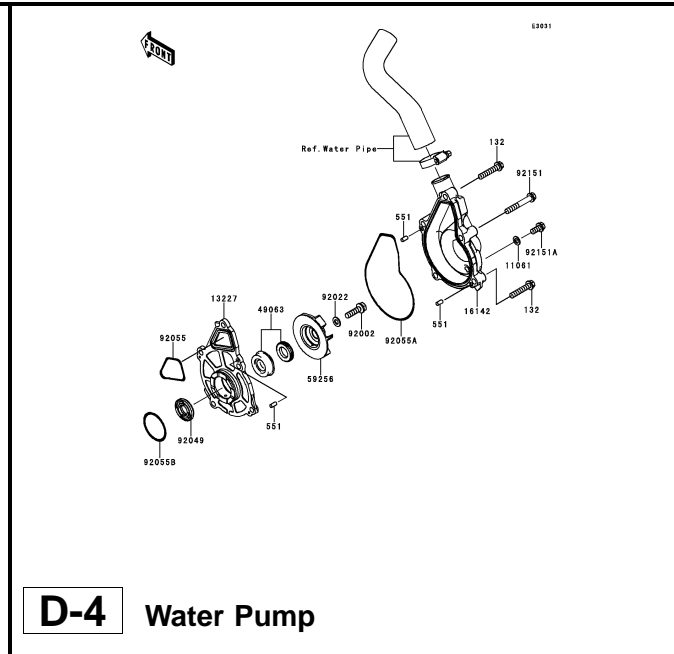
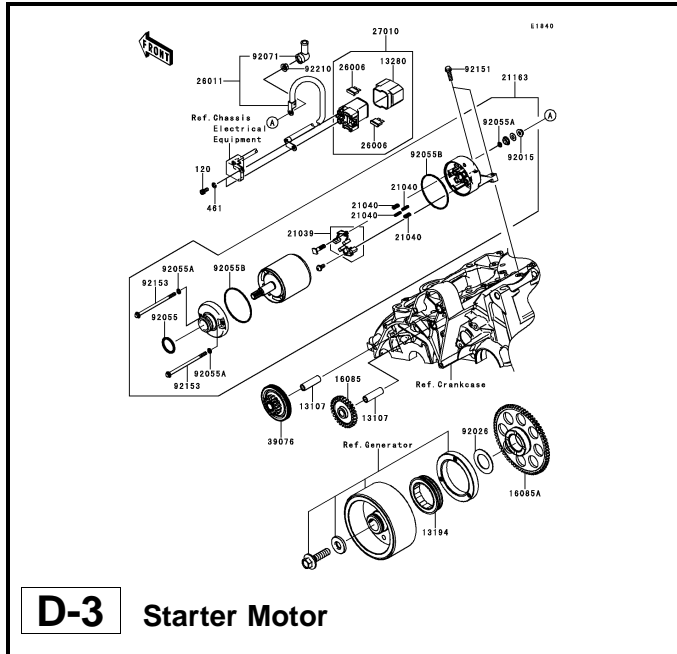

This catalog covers:

'09~'11 ER650 C9F/CAF/CBF Engine

GRID NO.

D-2

This grid covers:

Pictorial Index

This catalog covers:

'09~'11 ER650 C9F/CAF/CBF Chassis

GRID NO.

E-1

This grid covers:

Pictorial Index

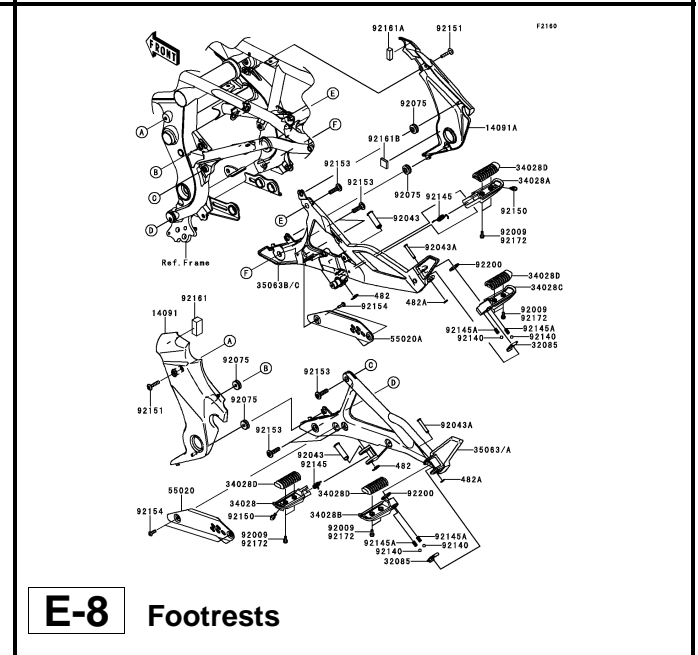
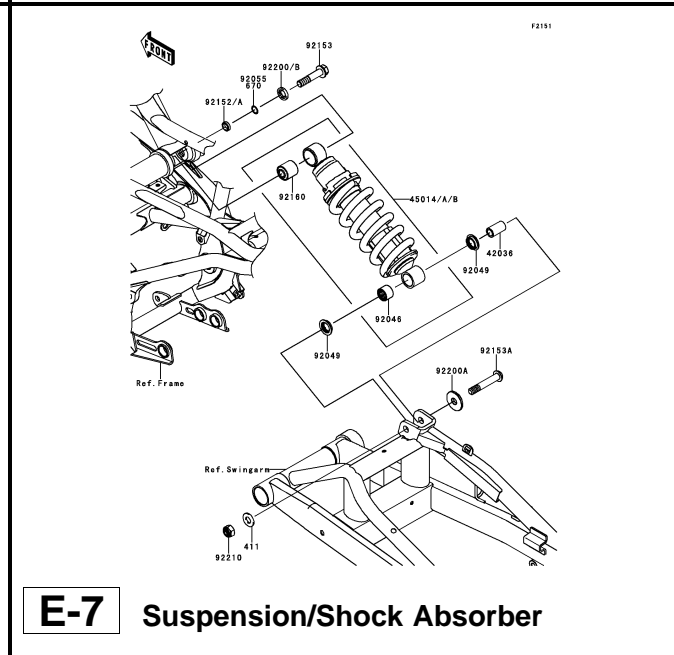
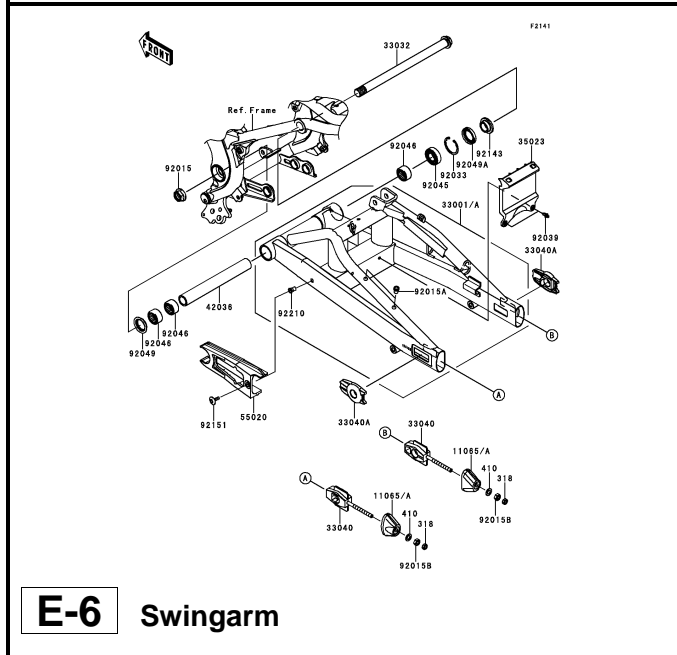
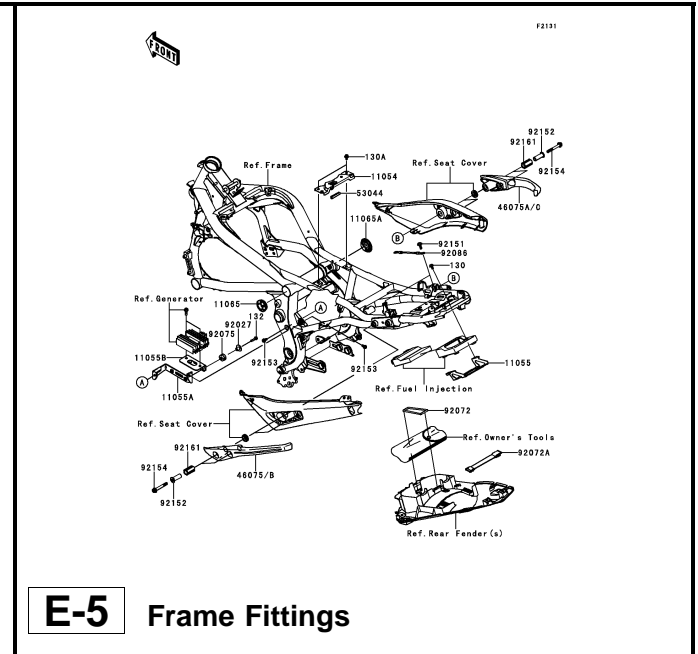
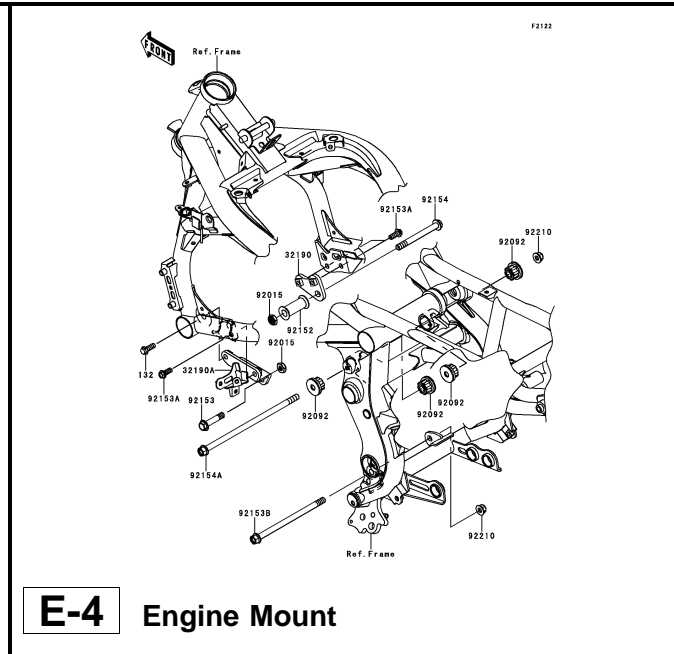
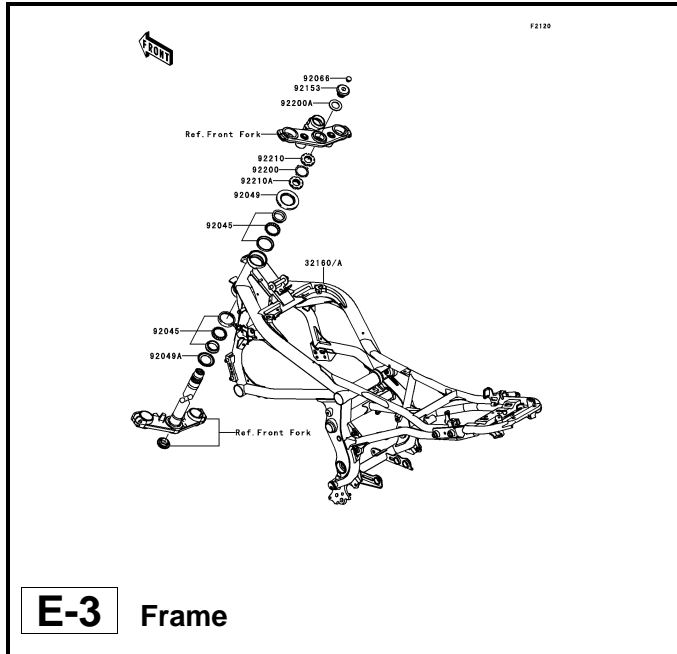

This catalog covers:

'09~'11 ER650 C9F/CAF/CBF Chassis

GRID NO.

E-2

This grid covers:

Pictorial Index

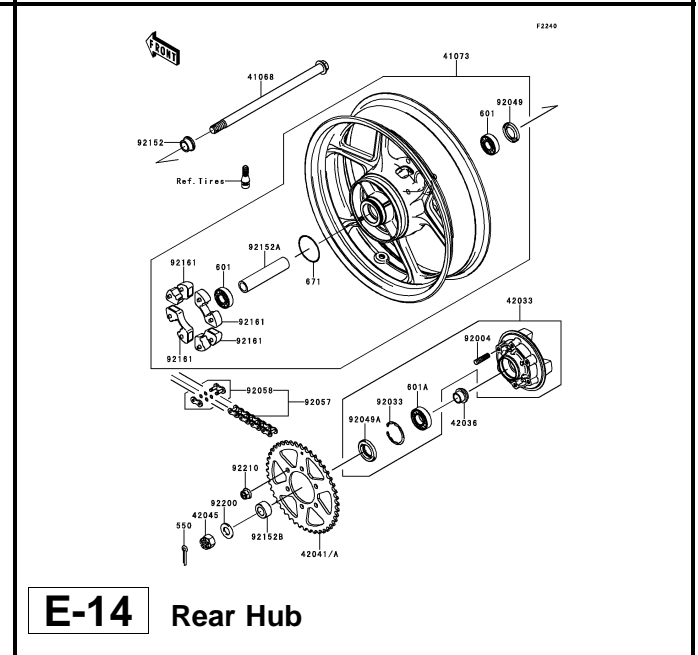
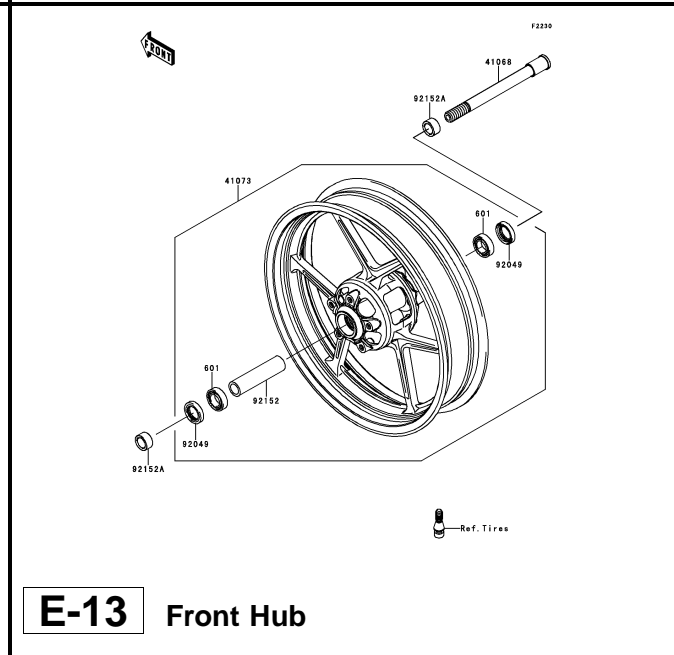
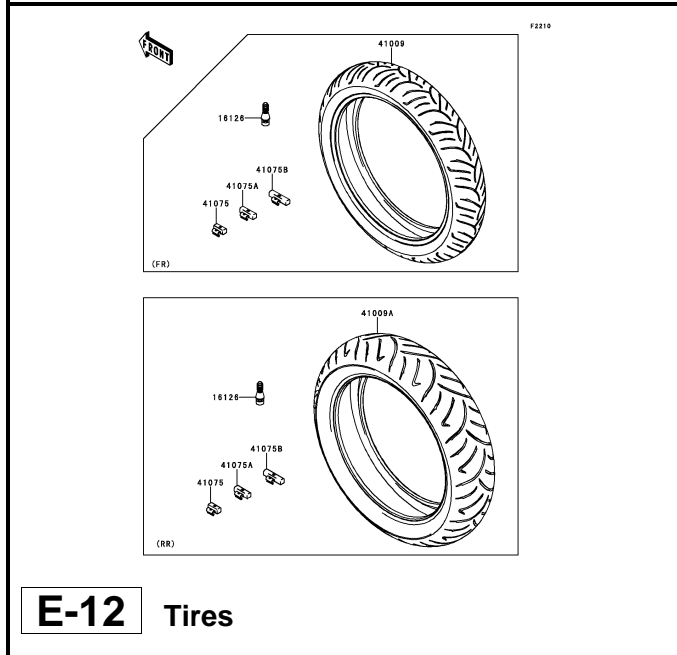
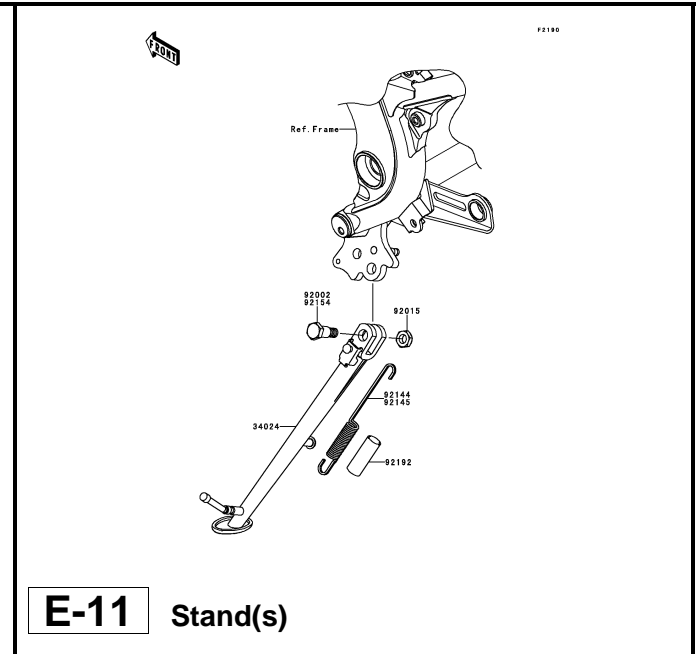
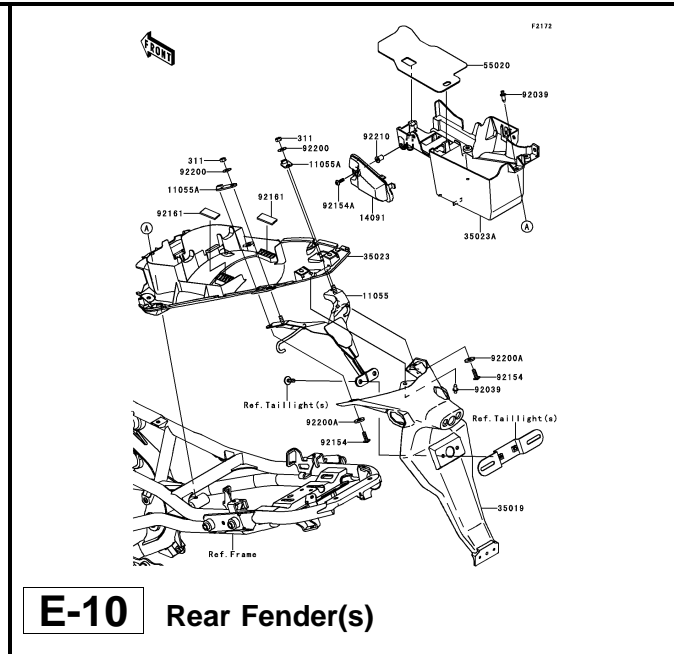
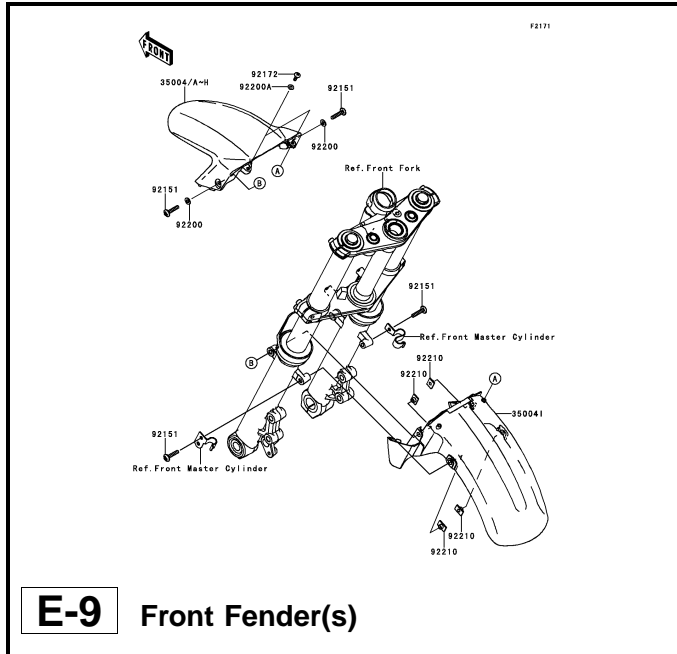

This catalog covers:

'09~'11 ER650 C9F/CAF/CBF Chassis

GRID NO.

F-1

This grid covers:

Pictorial Index

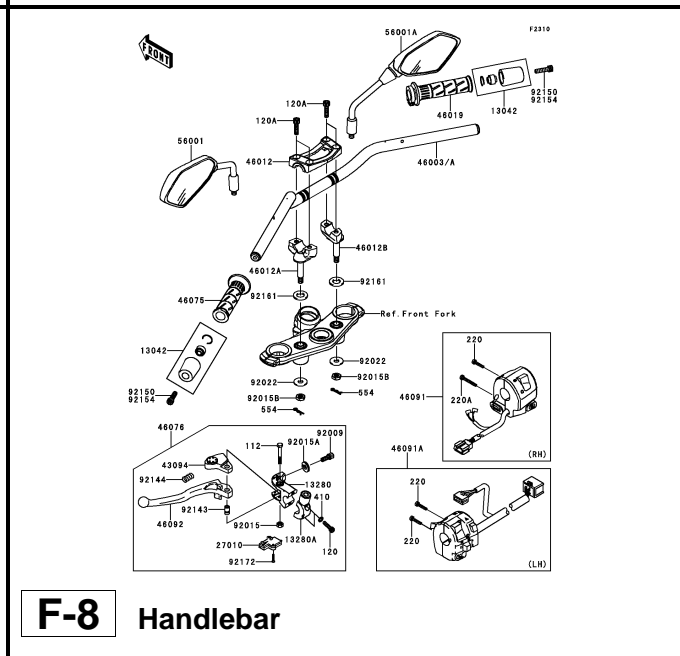
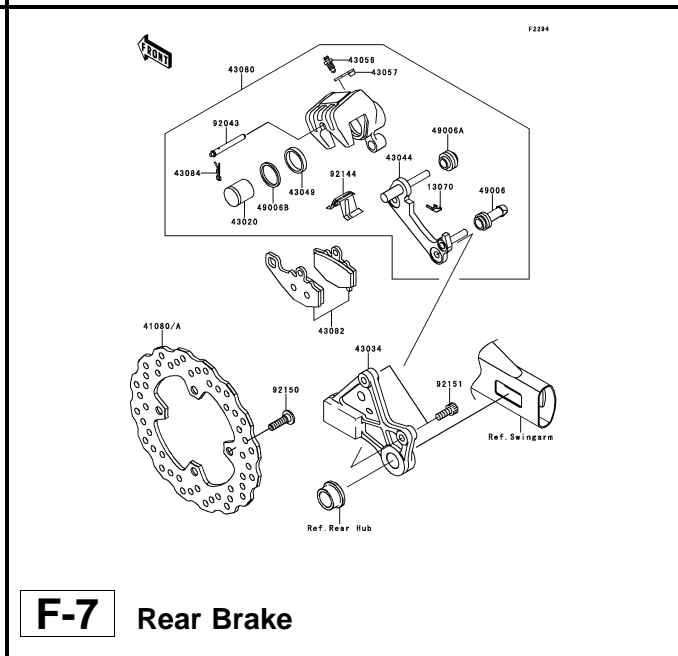
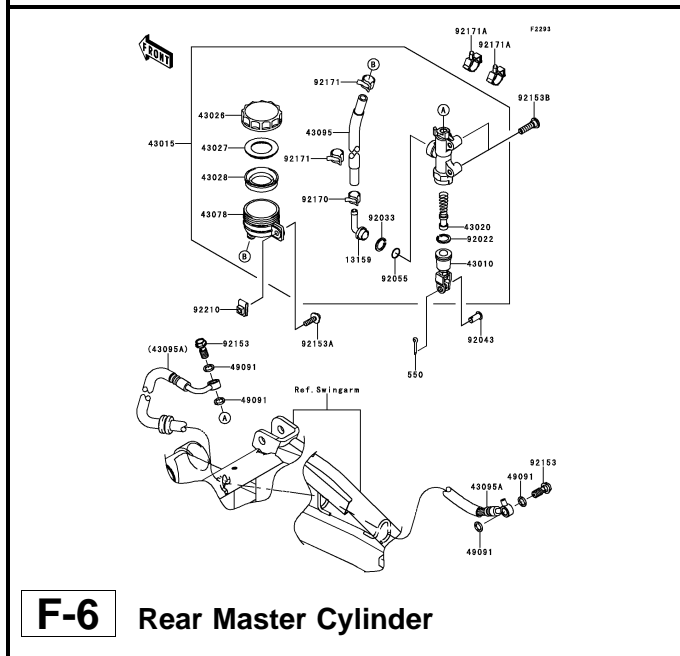
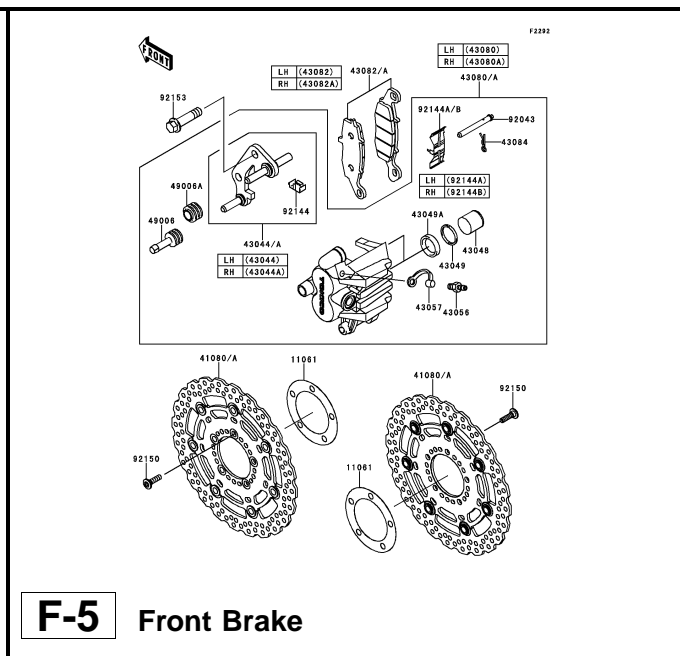
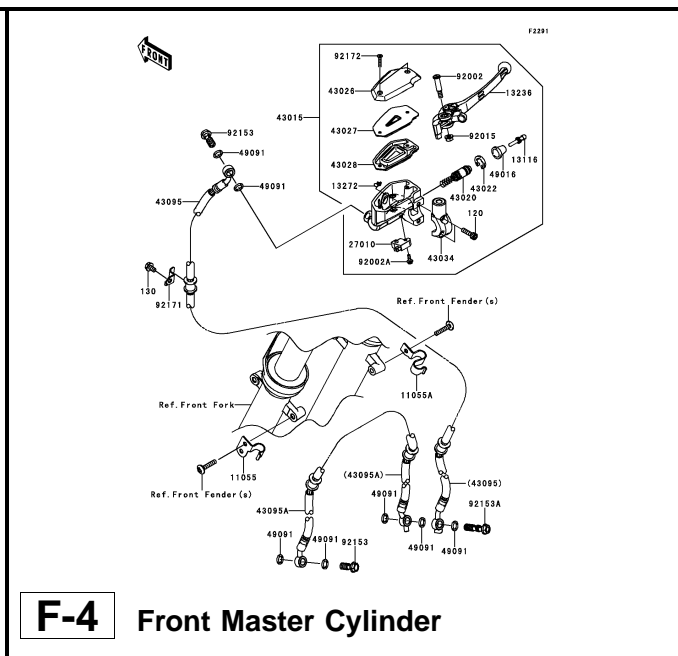
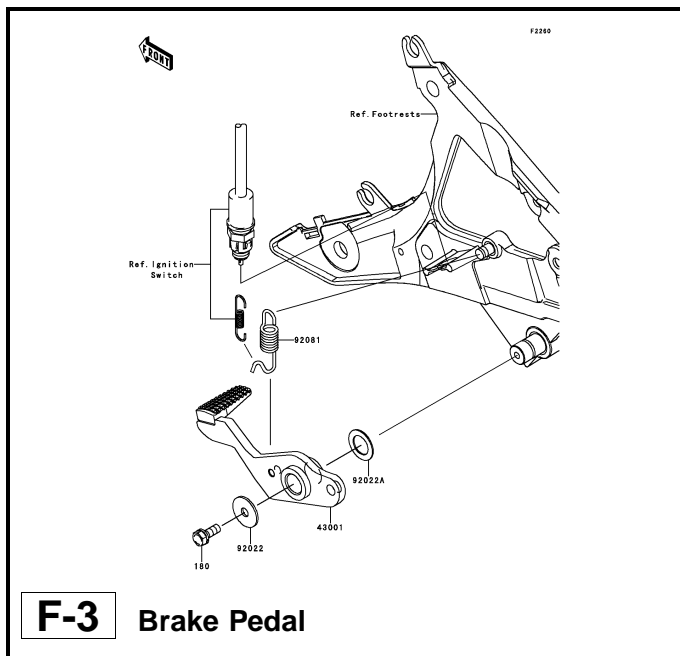

This catalog covers:

'09~'11 ER650 C9F/CAF/CBF Chassis

GRID NO.

F-2

This grid covers:

Pictorial Index

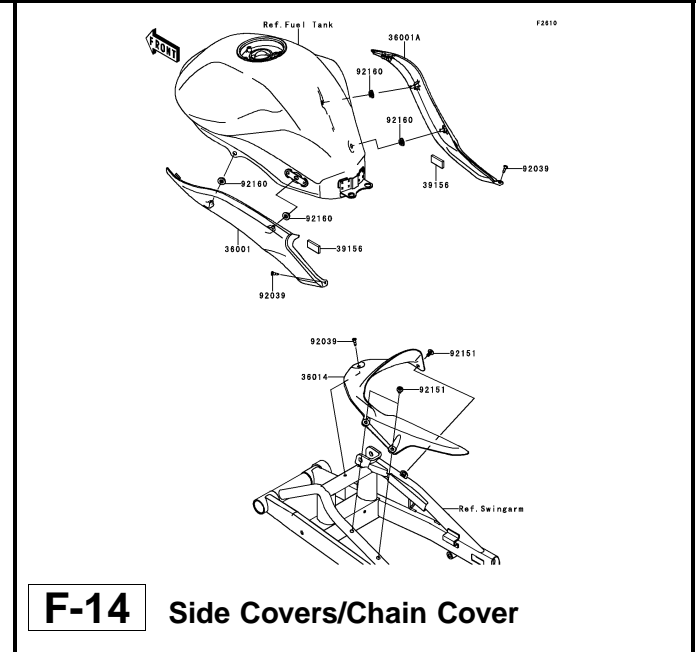
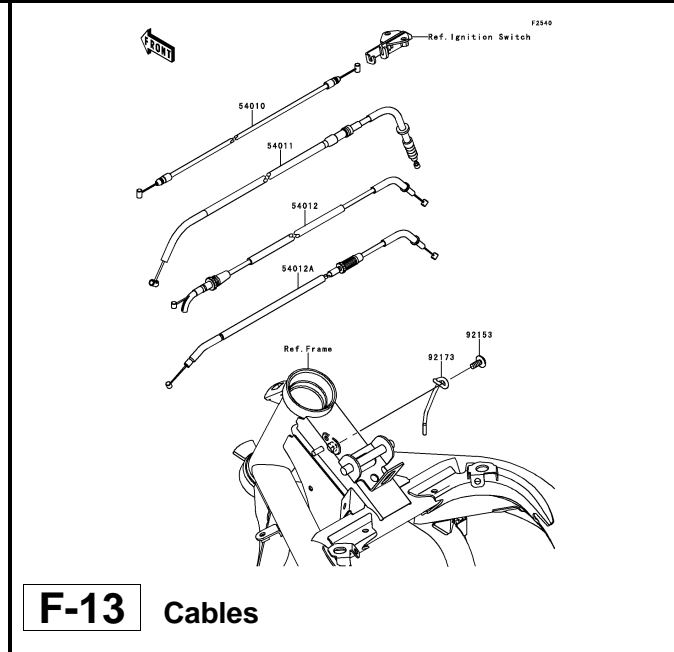
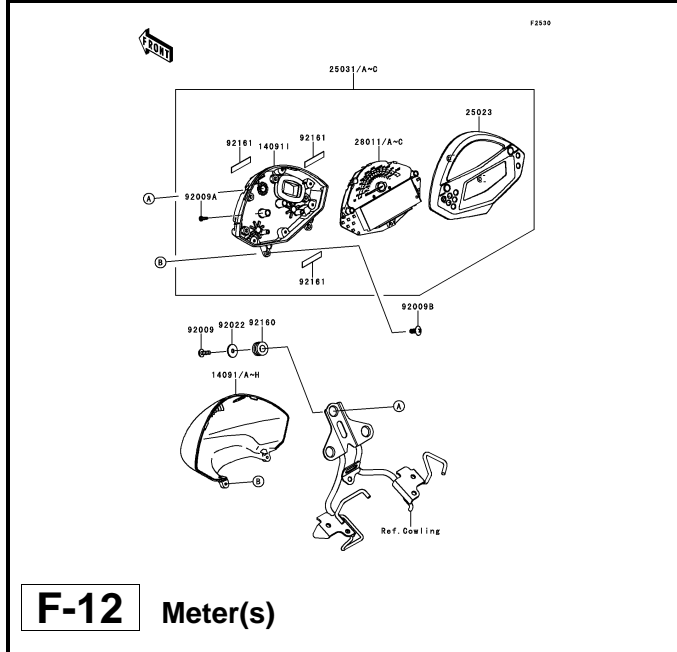
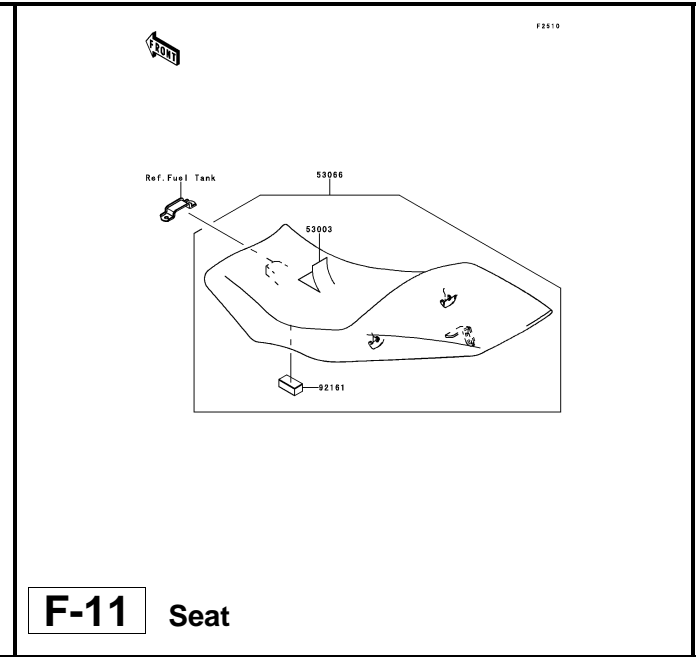
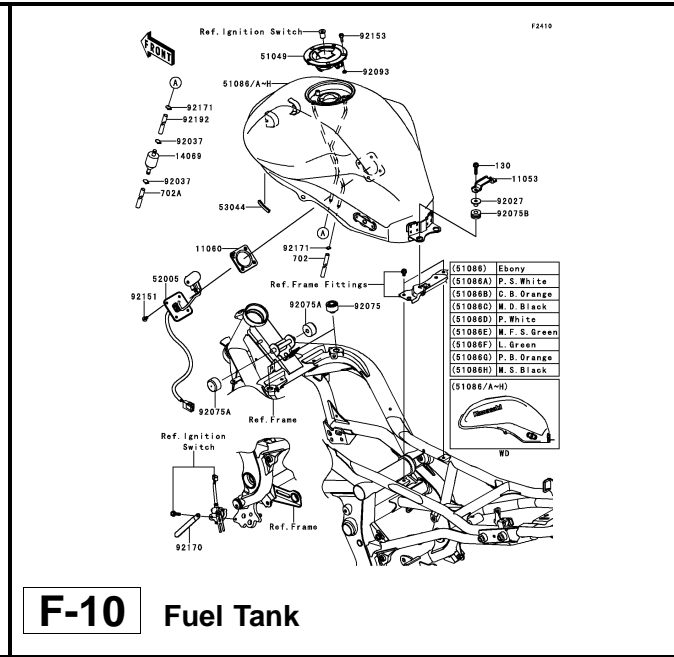
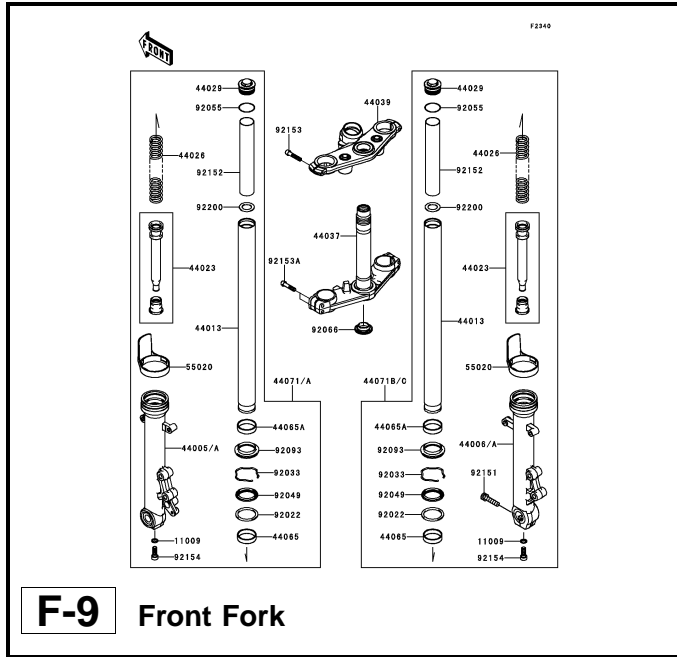

This catalog covers:

'09~'11 ER650 C9F/CAF/CBF Chassis

GRID NO.

G-1

This grid covers:

Pictorial Index

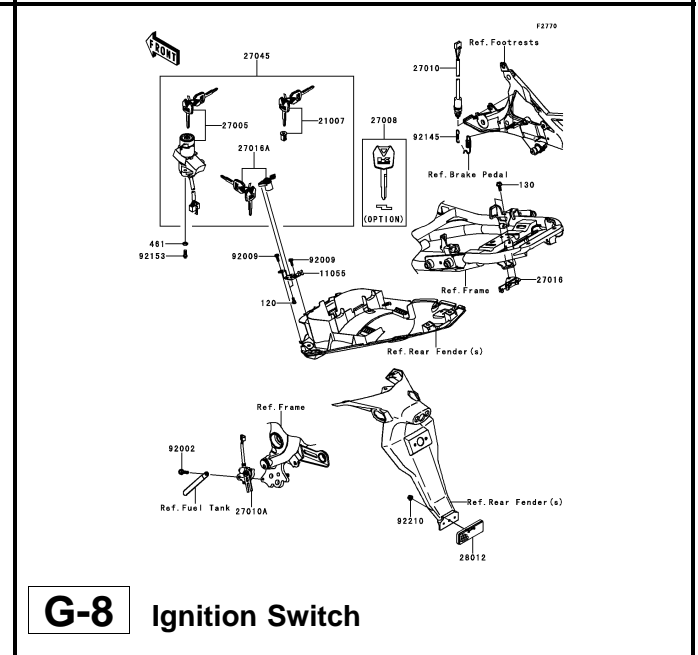
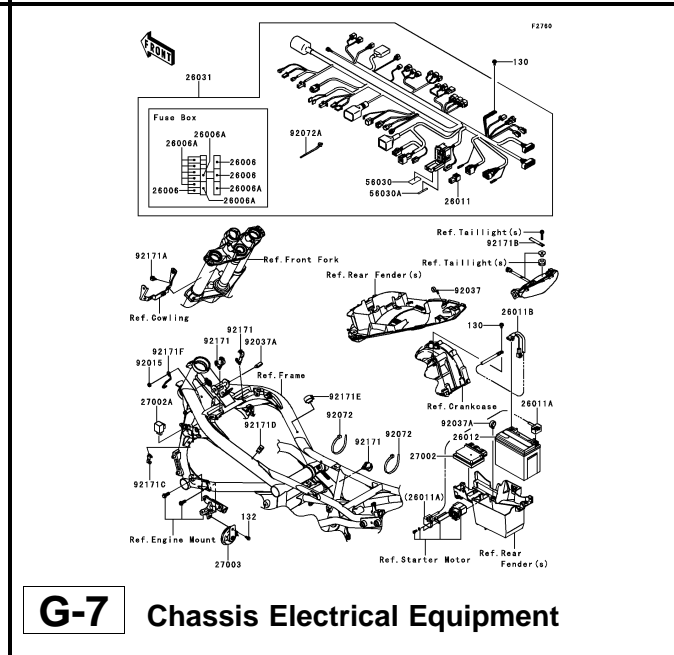
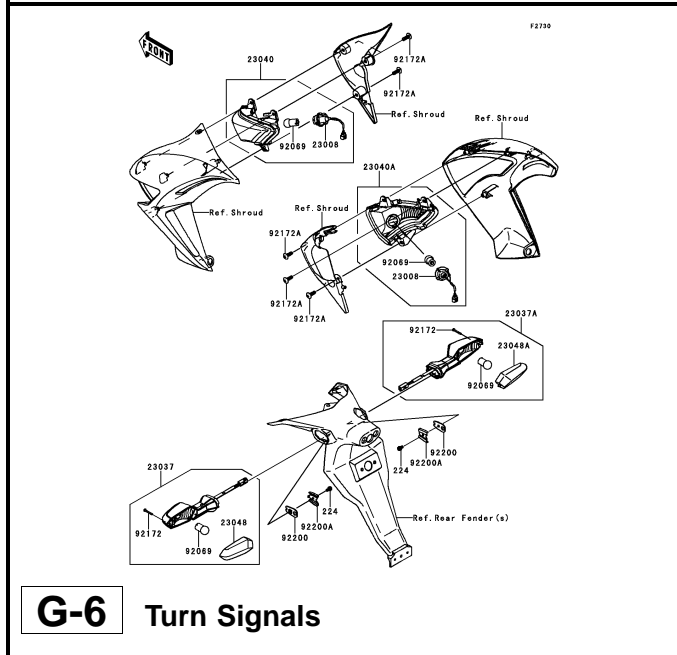
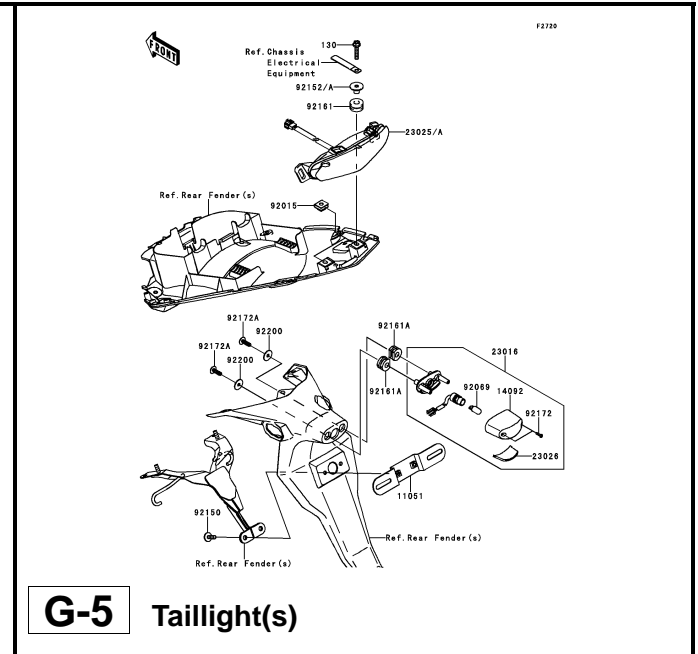
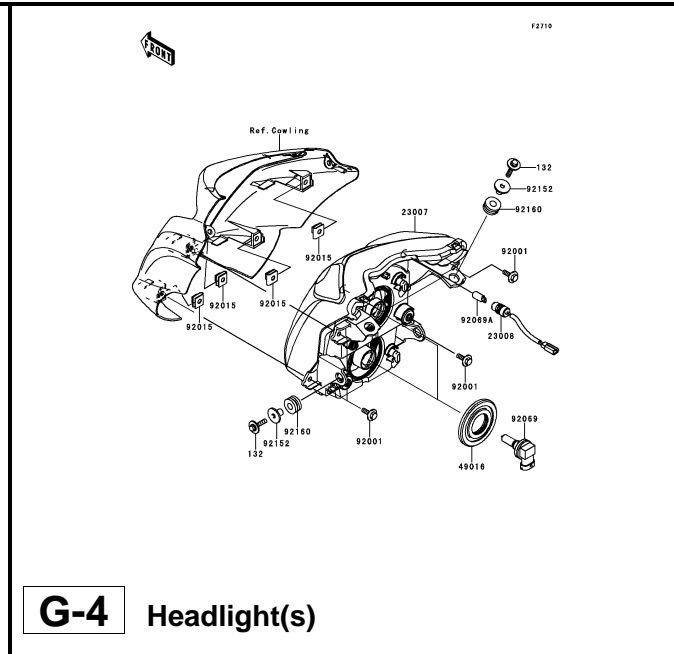
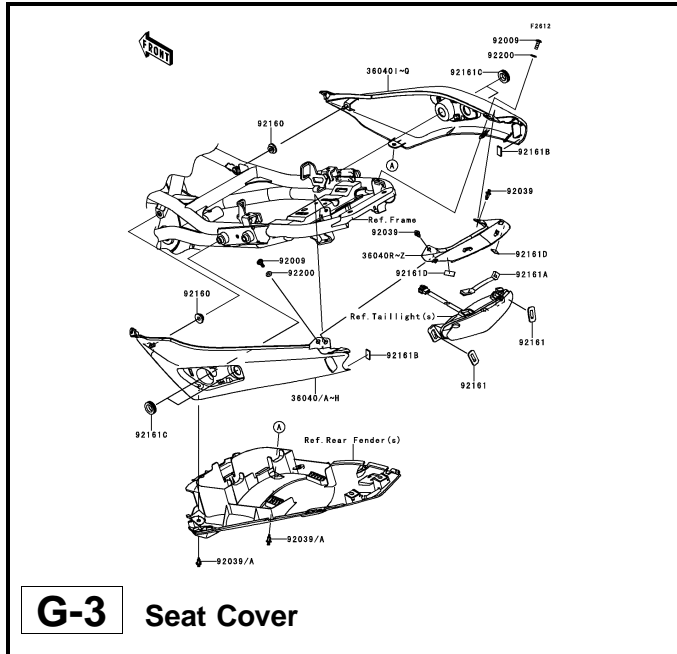

This catalog covers:

'09~'11 ER650 C9F/CAF/CBF Chassis

GRID NO.

G-2

This grid covers:

Pictorial Index

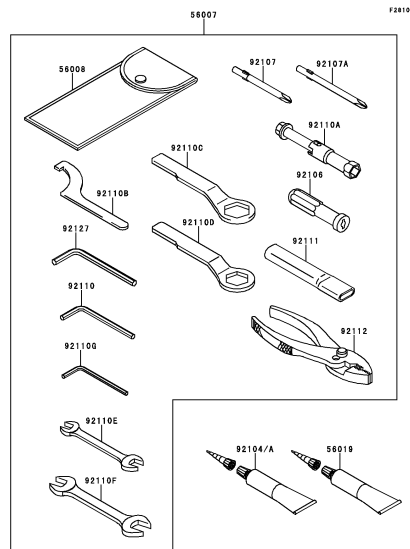

G-9 Owner's Tools

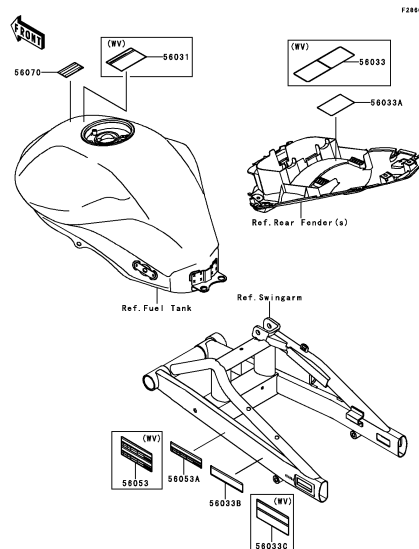

G-10 Labels

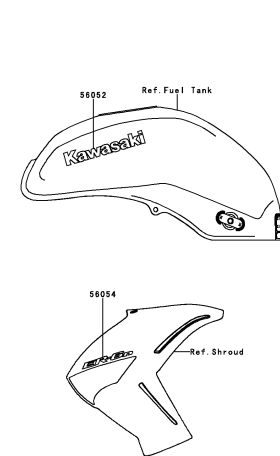

G-11 Decals(C.B.Orange)(P.S.White)(C9F)

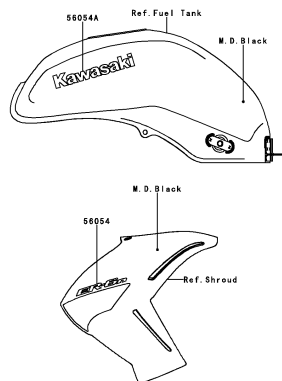

G-12 Decals(M.D.Black)(C9F)

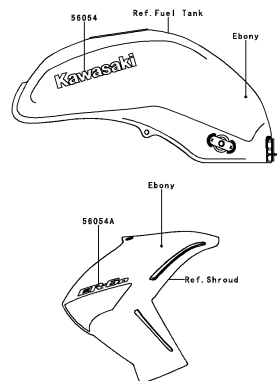

G-13 Decals(Ebony)(CAF)

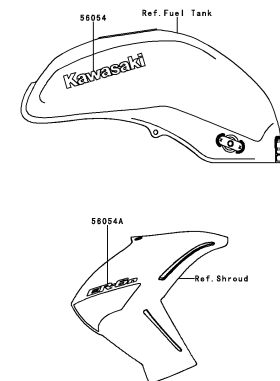

G-14 Decals(Orange)(CAF)(P.White)(CBF)

This catalog covers:

'09~'11 ER650 C9F/CAF/CBF Chassis

GRID NO.

H-1

This grid covers:

Pictorial Index

F2810

H-3 Decals(L.Green)(CAF)

F2811

H-4 Decals(M.F.S.Green)(CBF)

F2811F

H-5 Decals(M.S.Black)(CBF)

F2871

H-6 Cowling

F2875

(49125/A-Q)	(49125/I) P. White	(49125P/D) M. S. Black
(49125A/J)	Ebony	(49125P/P) M. F. S. Green
(49125B/K)	M. D. Black	(49125H/Q) P. D. Orange
(49125C/L)	P. S. White	
(49125D/M)	C. B. Orange	
(49125E/N)	M. F. S. Black	

H-7 Shroud

F2820

Owner's Manual (Local Procurement)

Ref. No.	Language
99976/A-E	English
99976/B/D	French
99976/C	German
99976A/C/E	Italian
99976A/C/E	Spanish
99986/A/B	Dutch
99986/A/B	English

Service Manual

Ref. No.	Language
99901	English
99904	Dutch
99903	French
99905	German
99905	Italian
99905	Spanish

A&P Manual

Ref. No.	Language
99903	Dutch
99903	English
99904	German
99905	French
99905	Italian
99905	Spanish

H-8 Manual

This catalog covers:

'09~'11 ER650 C9F/CAF/CBF Chassis

GRID NO.

H-2

This grid covers:

Pictorial Index

This catalog covers:

'09~'11 ER650 C9F/CAF/CBF Engine

GRID NO.

B-3

This grid covers:

Cylinder Head

E1111

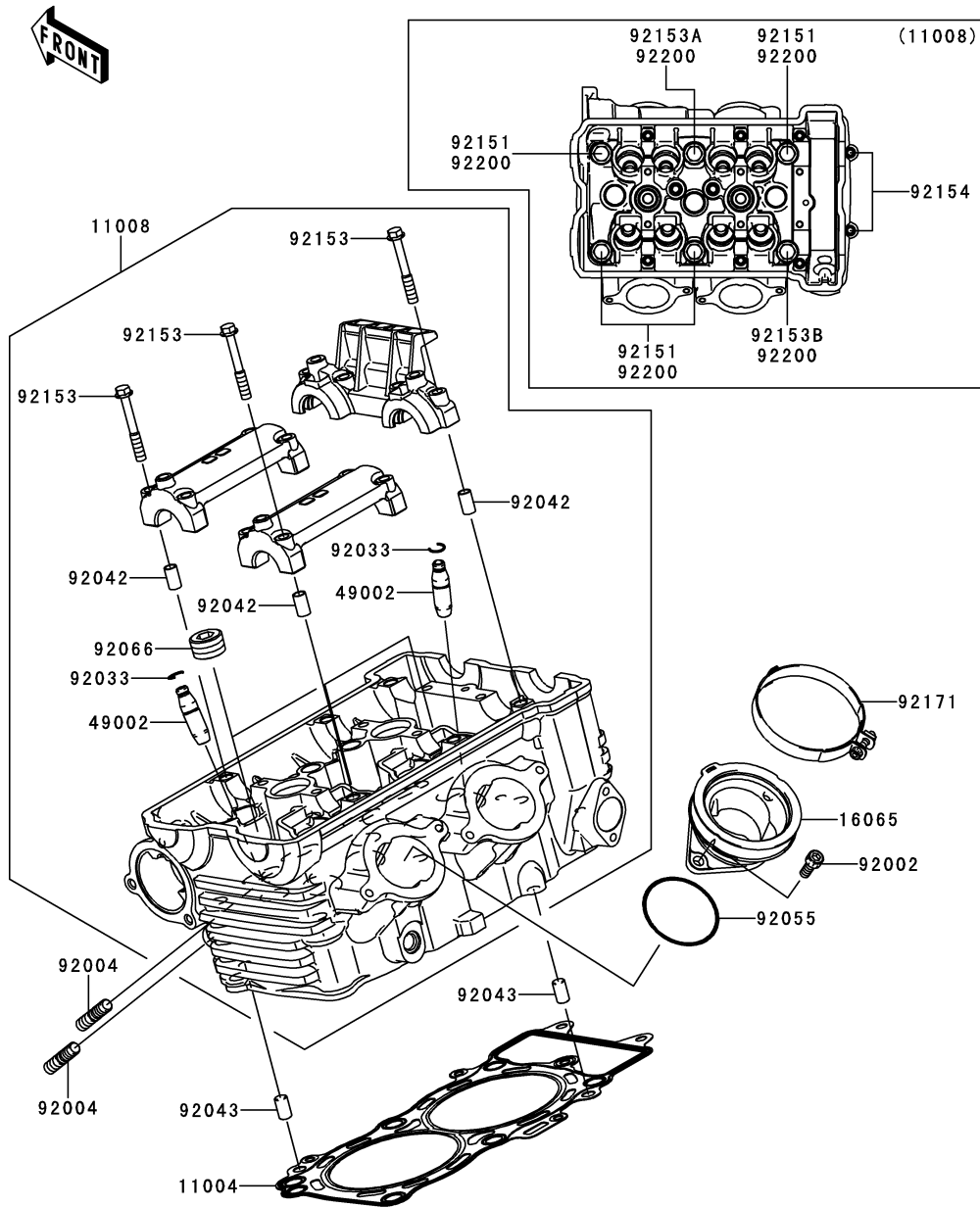

Ref. No.	Part No.	Description	Spec Code	Quantity-ER650		
				'09	'10	'11
				C9F	CAF	CBF
11004	11004-0064	GASKET-HEAD	1	1	1	
11008	11008-0182	HEAD-COMP-CYLINDER	1	1	1	
16065	16065-0024	HOLDER, THROTTLE BODY	2	2	2	
49002	49002-1116	GUIDE-VALVE	AR	AR	AR	
92002	92002-1143	BOLT, 6X16	4	4	4	
92004	92004-0025	STUD, 8X22	4	4	4	
92033	92033-1247	RING-SNAP	8	8	8	
92042	92042-007	PIN, DOWEL, 6.3X8X14	6	6	6	
92043	92043-1567	PIN, 8X14	2	2	2	
92055	92055-1600	RING-O, 47X1.9	2	2	2	
92066	92066-0002	PLUG, PT1/2X12.5	3	3	3	
92151	92151-1152	BOLT, 10X158	4	4	4	
92153	92153-0339	BOLT, 6X45	12	12	12	
92153A	92153-0972	BOLT, FLANGED-SMALL, 10X176	1	1	1	
92153B	92153-1321	BOLT, FLANGED-SMALL, 10X80	1	1	1	
92154	92154-0116	BOLT, SOCKET, 6X30	2	2	2	
92171	92171-1089	CLAMP	2	2	2	
92200	92200-0363	WASHER, 10.5X19X2.3	6	6	6	

This catalog covers:

'09~'11 ER650 C9F/CAF/CBF Engine

GRID NO.

B-4

This grid covers:

Cylinder Head Cover

E1112

Ref. No.	Part No.	Description	Spec Code	Quantity-ER650		
				'09	'10	'11
				C9F	CAF	CBF
11055	11055-1122	BRACKET	1	1	1	
11061	11061-0105	GASKET,SPARK PLUG HOLE	2	2	2	
11061A	11061-0170	GASKET,HEAD COVER	1	1	1	
11065	11065-0286	CAP	1	1	1	
12021	12021-1130	VALVE-ASSY-REED	1	1	1	
14091	14091-1702	COVER,HEAD	1	1	1	
92043	92043-4009	PIN,10.1X12X14	2	2	2	
92055	92055-0195	RING-O,HEAD COVER BOLT	4	4	4	
92153	92153-0793	BOLT,HEAD COVER	4	4	4	
92171	92171-0789	CLAMP,BRAKE HOSE	1	1	1	
92171A	92171-0813	CLAMP	1	1	1	
132	132BA0618	BOLT-FLANGED-SMALL,6X18	2	2	2	
132A	132BB0612	BOLT-FLANGED-SMALL,6X12	1	1	1	

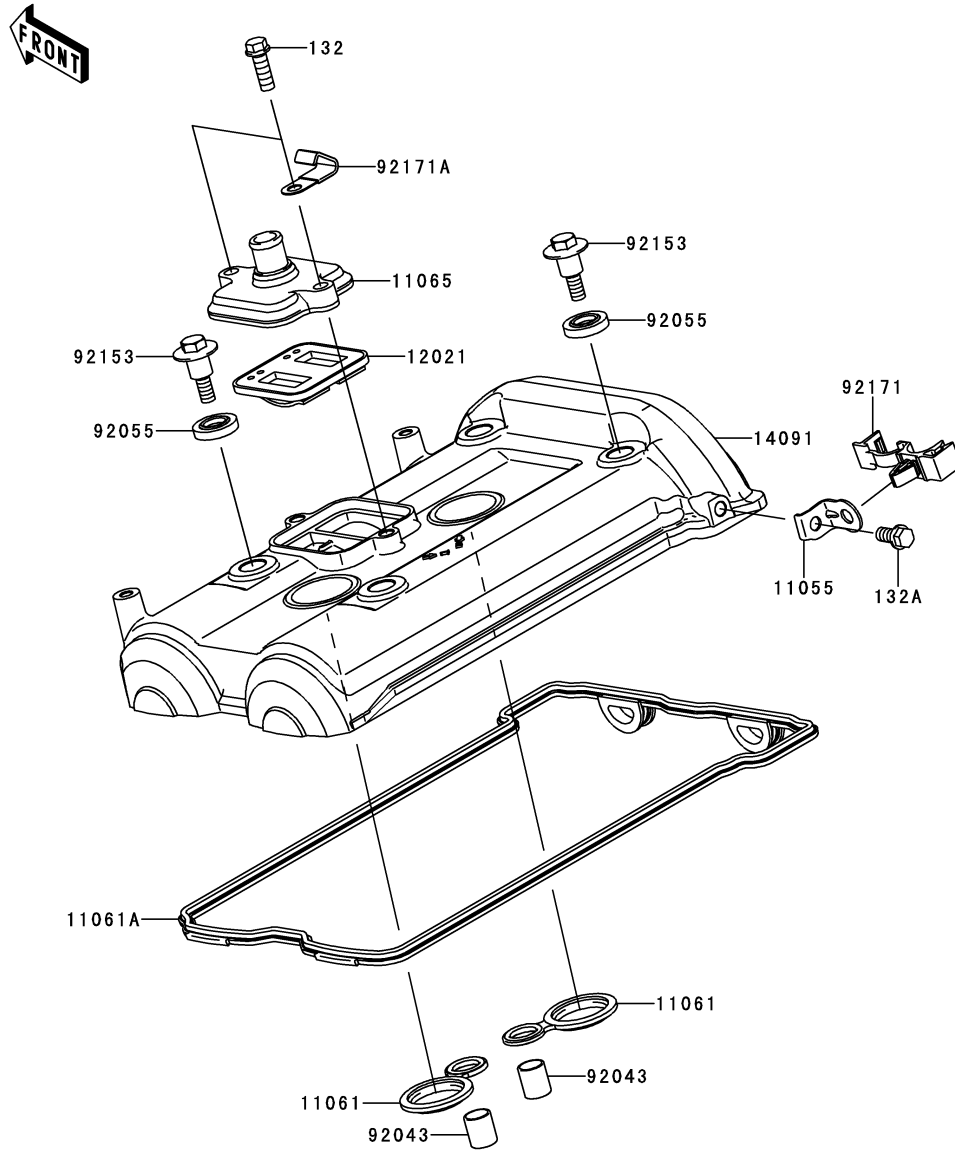

This catalog covers:

'09~'11 ER650 C9F/CAF/CBF Engine

GRID NO.

B-5

This grid covers:

Cylinder/Piston(s)

E1120

Ref. No.	Part No.	Description	Spec Code	Quantity-ER650		
				'09	'10	'11
				C9F	CAF	CBF
11005	11005-0114	CYLINDER-ENGINE	1	1	1	
11061	11061-0171	GASKET,CYLINDER BASE	1	1	1	
13001	13001-0087	PISTON-ENGINE	2	2	2	
13002	13002-0007	PIN-PISTON	2	2	2	
13008	13008-1196	RING-SET-PISTON	2	2	2	
92022	92022-1401	WASHER,9X15.5X2	1	1	1	
92036	92036-008	RING-SNAP,PISTON PIN	4	4	4	
92043	92043-1567	PIN,8X14	2	2	2	
92153	92153-1011	BOLT,8X43	1	1	1	
92154	92154-0116	BOLT,SOCKET,6X30	2	2	2	
92200	92200-0363	WASHER,10.5X19X2.3	1	1	1	
92210	92210-0223	NUT	1	1	1	

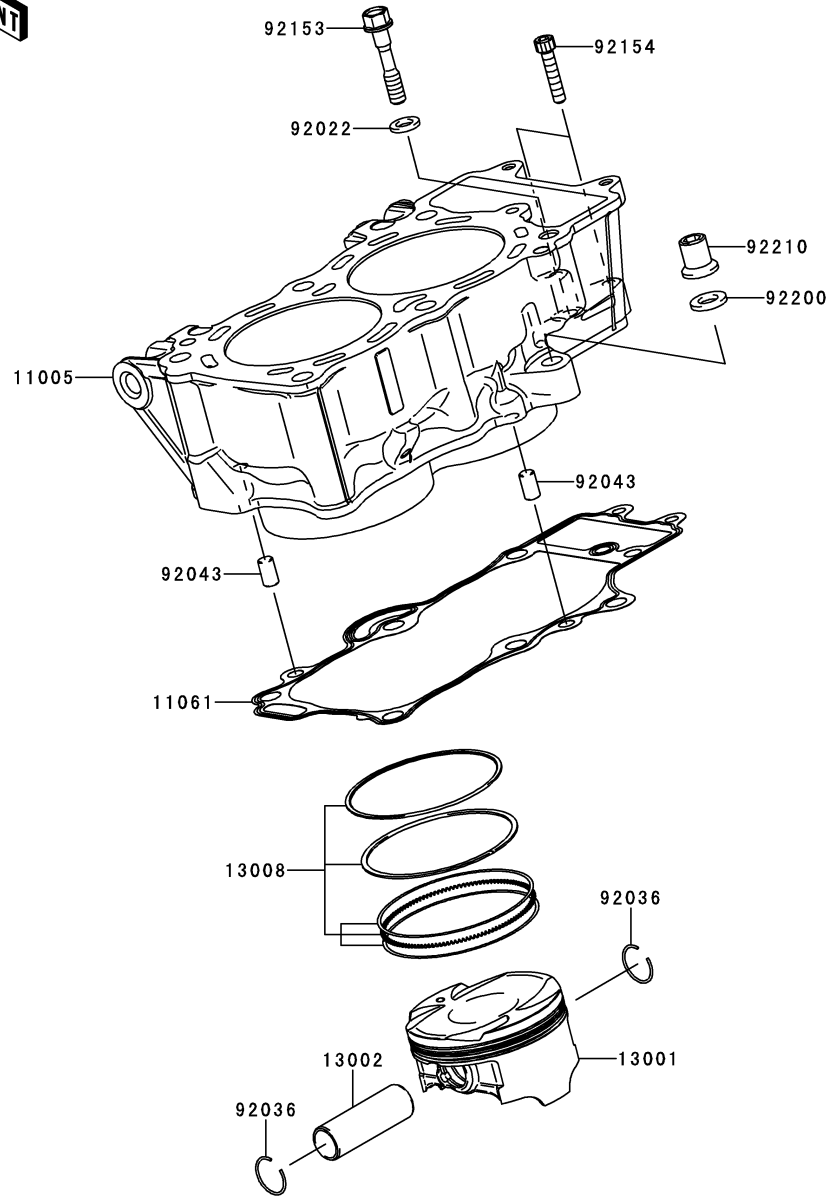

This catalog covers:

'09~'11 ER650 C9F/CAF/CBF Engine

GRID NO.

B-6

This grid covers:

Air Cleaner

E1130

Ref. No.	Part No.	Description	Spec Code	Quantity-ER650		
				'09	'10	'11
				C9F	CAF	CBF
11010	11010-0156	FILTER-ASSY-AIR	1	1	1	
11029	11029-0011	ELEMENT-ASSY-AIR FILTER	1	1	1	
11065	11065-0120	CAP,UPPER CASE	1	1	1	
14073	14073-0210	DUCT,INLET	2	2	2	
14079	14079-0064	HOLDER-ASSY	1	1	1	
16126	16126-0019	VALVE,AIR SWITING	1	1	1	
92009	92009-1984	SCREW,TAPPING,5X16	4	4	4	
92066	92066-0127	PLUG,DRAIN,8.5X15	1	1	1	
92093	92093-0046	SEAL	1	1	1	
92093A	92093-0142	SEAL,CAP	1	1	1	
92153	92153-0759	BOLT,SOCKET,6X12	4	4	4	
92161	92161-0302	DAMPER,T=15	3	3	3	
92161A	92161-0309	DAMPER	1	1	1	
92170	92170-1017	CLAMP	1	1	1	
92171	92171-0314	CLAMP	2	2	2	
92171A	92171-1584	CLAMP,DRAIN	1	1	1	
92172	92172-0298	SCREW,TAPPING,5X20	1	1	1	
92173	92173-0001	CLAMP,22X2	1	1	1	
92192	92192-0232	TUBE,HEAD-ASV	1	1	1	
92192A	92192-0680	TUBE,A/C-ASV	1	1	1	
92192B	92192-0709	TUBE,8X12X245	1	1	1	
92192C	92192-0818	TUBE,BREATHER	1	1	1	

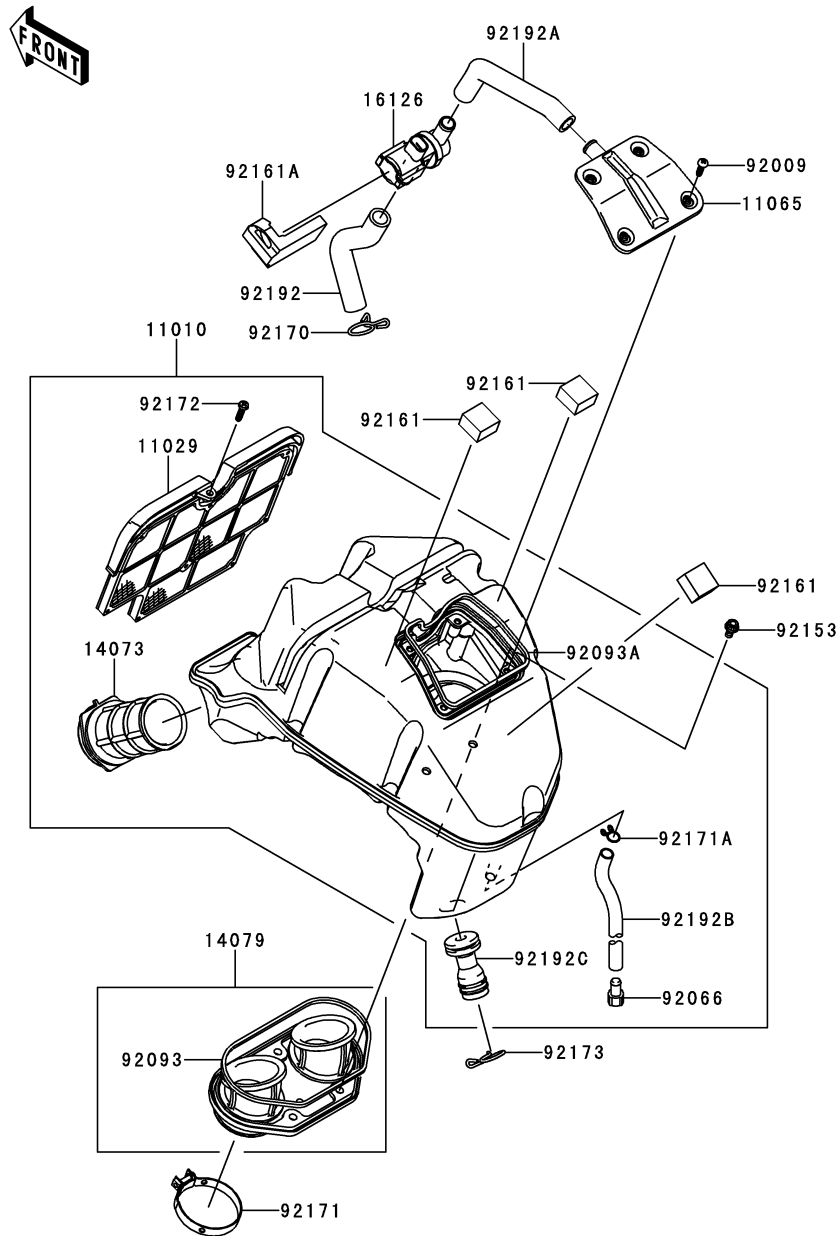

This catalog covers:

'09~'11 ER650 C9F/CAF/CBF Engine

GRID NO.

B-7

This grid covers:

Muffler(s)

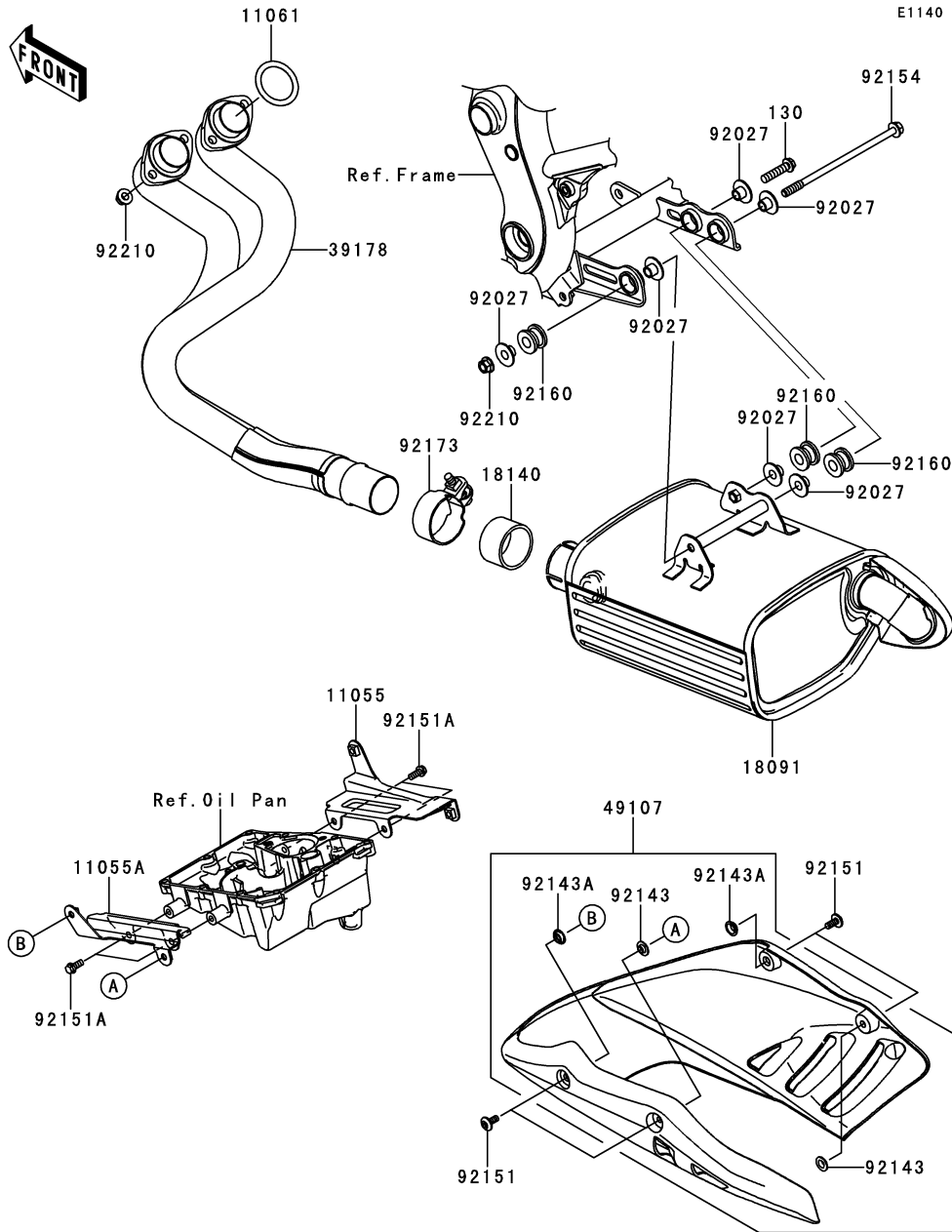

Ref. No.	Part No.	Description	Spec Code	Quantity-ER650		
				'09	'10	'11
				C9F	CAF	CBF
11055	11055-1106	BRACKET,RH	1	1	1	
11055A	11055-1107	BRACKET,LH	1	1	1	
11061	11061-0278	GASKET,EXHAUST PIPE	2	2	2	
18091	18091-0502	BODY-COMP-MUFFLER	1	1	1	
18140	18140-0002	GASKET-MUFFLER	1	1	1	
39178	39178-0073	MANIFOLD-COMP-EXHAUST	1	1	1	
49107	49107-0074-6Z	COVER-EXHAUST PIPE,F.BLACK	1	1	1	
92027	92027-1653	COLLAR,FLANGED,8.8X10.6	6	6	6	
92143	92143-1087	COLLAR	2	2	2	
92143A	92143-1196	COLLAR	2	2	2	
92151	92151-1654	BOLT,SOCKET,6X14	4	4	4	
92151A	92151-1755	BOLT,FLANGED,6X14	4	4	4	
92154	92154-0189	BOLT,FLANGED,8X165	1	1	1	
92160	92160-1116	DAMPER,MUFFLER MOUNT	3	3	3	
92173	92173-0110	CLAMP	1	1	1	
92210	92210-1114	NUT,8MM	5	5	5	
130	130CD0835	BOLT-FLANGED,8X35	1	1	1	

This catalog covers:

'09~'11 ER650 C9F/CAF/CBF Engine

GRID NO.

B-8

This grid covers:

Valve(s)

E1210

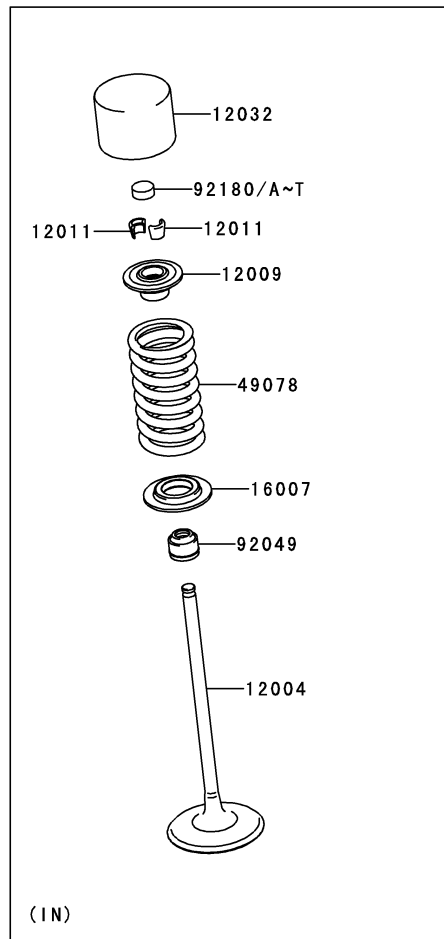
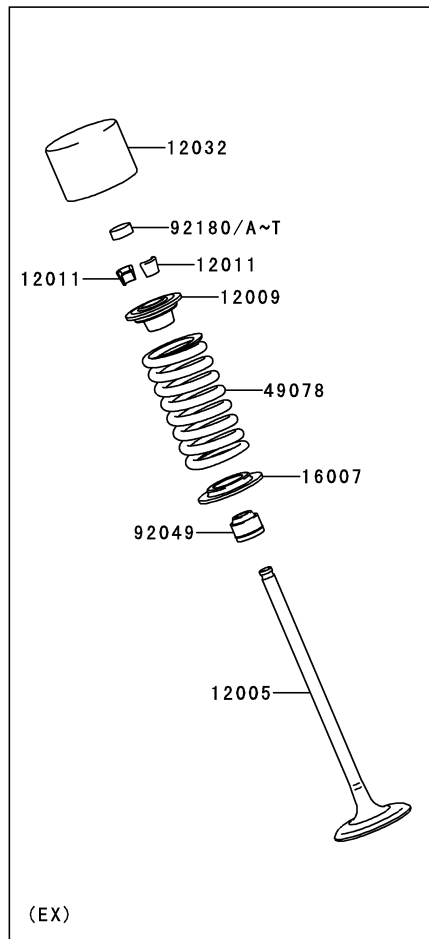

Ref. No.	Part No.	Description	Spec Code	Quantity-ER650			
				'09	'10	'11	
				C9F	CAF	CBF	
12004	12004-0015	VALVE-INTAKE	4	4	4		
12005	12005-0035	VALVE-EXHAUST	4	4	4		
12009	12009-1091	RETAINER-VALVE SPRING	8	8	8		
12011	12011-1053	COLLET	16	16	16		
12032	12032-0009	TAPPET	8	8	8		
16007	16007-1228	SEAT-SPRING	8	8	8		
49078	49078-0065	SPRING-ENGINE VALVE	8	8	8		
92049	92049-1349	SEAL-OIL,VSB 4.3 7.5 5.3 8.3	8	8	8		
92180	92180-1014	SHIM,T=2.50	AR	AR	AR		
92180A	92180-1016	SHIM,T=2.55	AR	AR	AR		
92180B	92180-1018	SHIM,T=2.60	AR	AR	AR		
92180C	92180-1020	SHIM,T=2.65	AR	AR	AR		
92180D	92180-1022	SHIM,T=2.70	AR	AR	AR		
92180E	92180-1024	SHIM,T=2.75	AR	AR	AR		
92180F	92180-1026	SHIM,T=2.80	AR	AR	AR		
92180G	92180-1028	SHIM,T=2.85	AR	AR	AR		
92180H	92180-1030	SHIM,T=2.90	AR	AR	AR		
92180I	92180-1032	SHIM,T=2.95	AR	AR	AR		
92180J	92180-1034	SHIM,T=3.00	8	8	8		
92180K	92180-1036	SHIM,T=3.05	AR	AR	AR		
92180L	92180-1038	SHIM,T=3.10	AR	AR	AR		
92180M	92180-1040	SHIM,T=3.15	AR	AR	AR		
92180N	92180-1042	SHIM,T=3.20	AR	AR	AR		
92180O	92180-1044	SHIM,T=3.25	AR	AR	AR		
92180P	92180-1046	SHIM,T=3.30	AR	AR	AR		
92180Q	92180-1048	SHIM,T=3.35	AR	AR	AR		
92180R	92180-1050	SHIM,T=3.40	AR	AR	AR		
92180S	92180-1052	SHIM,T=3.45	AR	AR	AR		
92180T	92180-1054	SHIM,T=3.50	AR	AR	AR		

This catalog covers:

'09~'11 ER650 C9F/CAF/CBF Engine

GRID NO.

B-9

This grid covers:

Camshaft(s)/Tensioner

E1230

Ref. No.	Part No.	Description	Spec Code	Quantity-ER650		
				'09	'10	'11
				C9F	CAF	CBF
12046	12046-0041	SPROCKET,CAM,34T	2	2	2	
12048	12048-0038	TENSIONER-ASSY	1	1	1	
12053	12053-0051	GUIDE-CHAIN,UPP	1	1	1	
12053A	12053-0059	GUIDE-CHAIN,FR	1	1	1	
12053B	12053-0075	GUIDE-CHAIN,RR	1	1	1	
49118	49118-0042	CAMSHAFT-COM,EX	1	1	1	
49118A	49118-0072	CAMSHAFT-COM,IN	1	1	1	
92003	92003-208	BOLT,FLANGED,6X11	4	4	4	
92055	92055-086	RING-O,18.8X1.9	1	1	1	
92057	92057-0100	CHAIN,CAM,92RH 2015-134M	1	1	1	
92152	92152-0306	COLLAR,8.2X10.6X6.9	2	2	2	
92153	92153-1394	BOLT,FLANGED-SMALL,8X35	1	1	1	
92154	92154-0117	BOLT,FLANGED-SMALL,6X25	2	2	2	

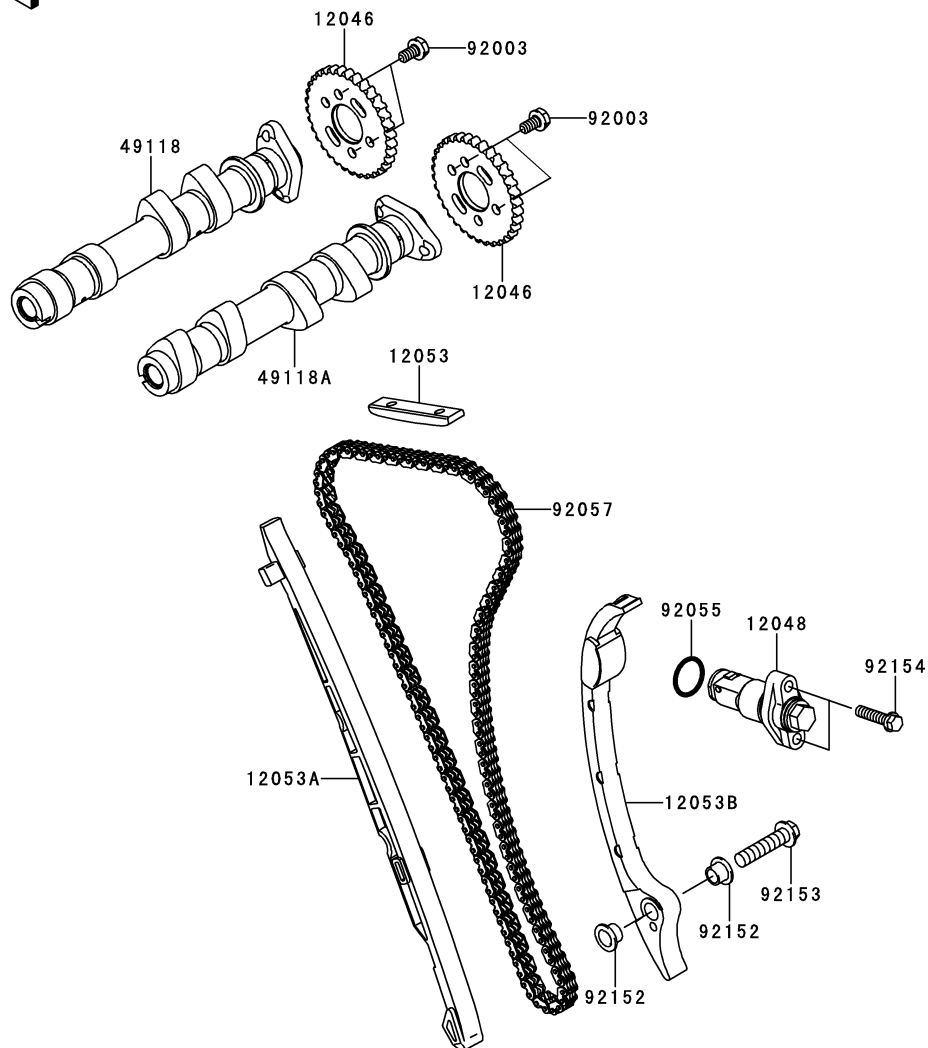

This catalog covers:

'09~'11 ER650 C9F/CAF/CBF Engine

GRID NO.

B-10

This grid covers:

Crankshaft

E1321

Ref. No.	Part No.	Description	Spec Code	Quantity-ER650		
				'09	'10	'11
				C9F	CAF	CBF
13031	13031-0097	CRANKSHAFT-COMP	1	1	1	
13251	13251-0010-KK	ROD-ASSY-CONNECTING,K	AR	AR	AR	
92015	92015-1311	NUT,FLANGED,8MM	4	4	4	
92028	92028-1903	BUSHING,CRANKSHAFT,BLUE	6	6	6	
92028A	92028-1904	BUSHING,CRANKSHAFT,BLACK	AR	AR	AR	
92028B	92028-1905	BUSHING,CRANKSHAFT,BROWN	AR	AR	AR	
92139	92139-0114	BUSHING,CON-ROD,BLUE	4	4	4	
92139A	92139-0115	BUSHING,CON-ROD,BLACK	AR	AR	AR	
92139B	92139-0116	BUSHING,CON-ROD,BROWN	AR	AR	AR	
92153	92153-0957	BOLT,CON-ROD,8X49	4	4	4	
555	555A0408	PIN-SPRING,4X8	1	1	1	

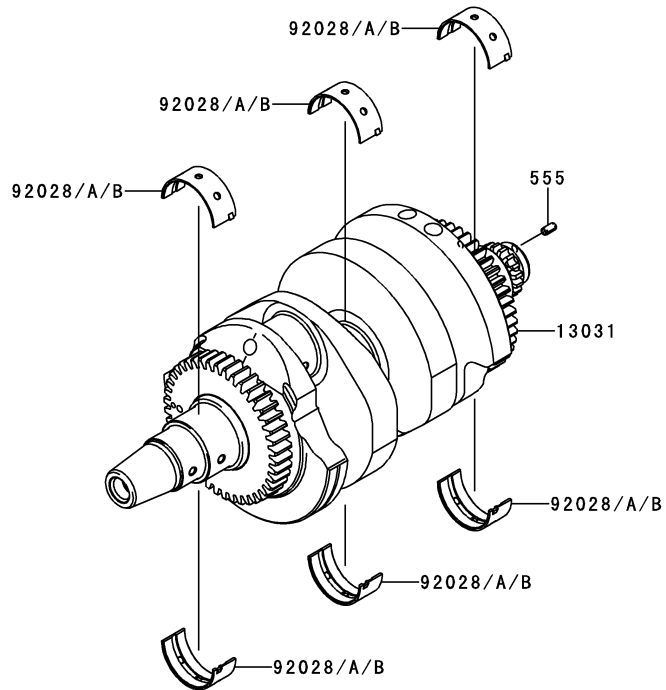
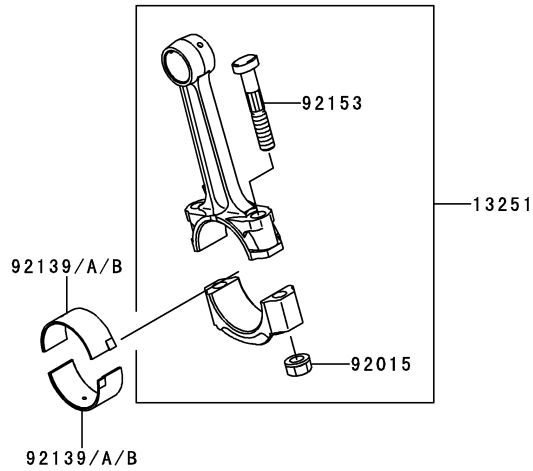

This catalog covers:

'09~'11 ER650 C9F/CAF/CBF Engine

GRID NO.

B-11

This grid covers:

Balancer



E1323

Ref. No.	Part No.	Description	Spec Code	Quantity-ER650			
				'09	'10	'11	
				C9F	CAF	CBF	
13234	13234-0043	SHAFT-COMP,BALANCER	1	1	1		
92139	92139-0117	BUSHING,BALANCER,BLUE	4	4	4		
92139A	92139-0118	BUSHING,BALANCER,BLACK	AR	AR	AR		
92139B	92139-0119	BUSHING,BALANCER,BROWN	AR	AR	AR		

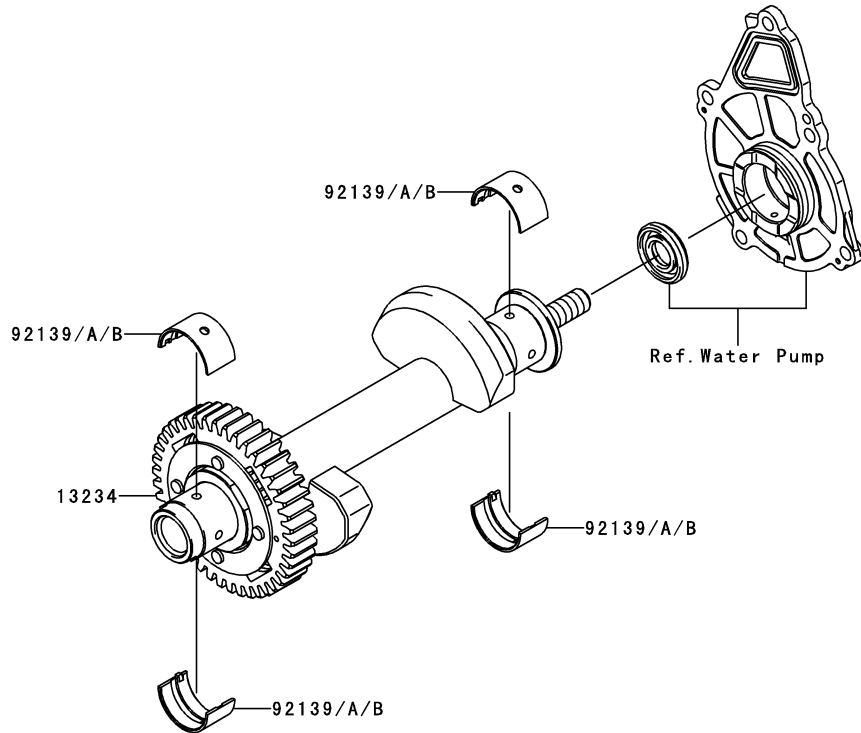

This catalog covers:

'09~'11 ER650 C9F/CAF/CBF Engine

GRID NO.

B-12

This grid covers:

Clutch

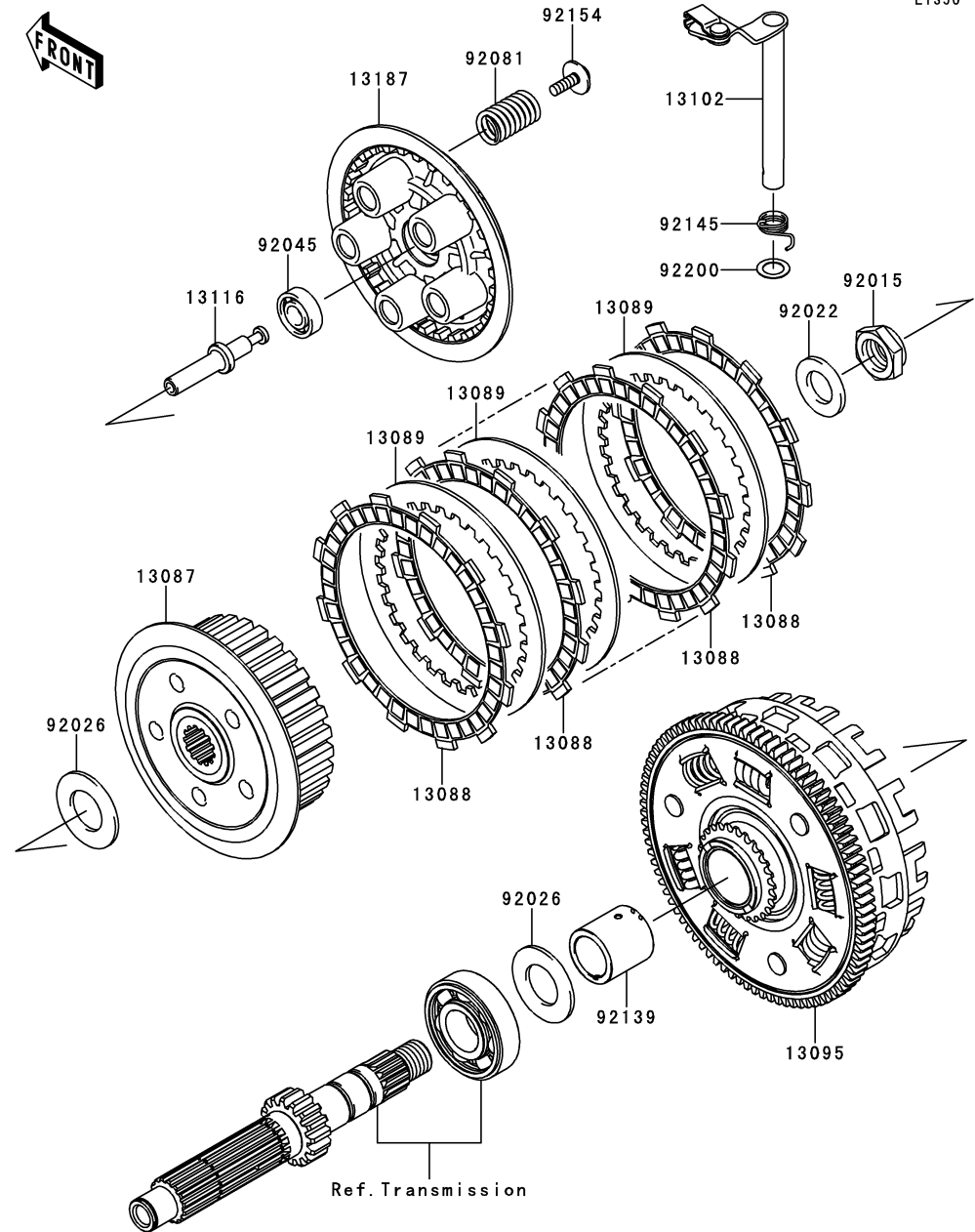

E1350

Ref. No.	Part No.	Description	Spec Code	Quantity-ER650		
				'09	'10	'11
				C9F	CAF	CBF
13087	13087-0046	HUB-CLUTCH	1	1	1	
13088	13088-1105	PLATE-FRICTION	7	7	7	
13089	13089-0016	PLATE-CLUTCH,T=2.3	6	6	6	
13095	13095-0115	HOUSING-COMP-CLUTCH	1	1	1	
13102	13102-0037	RELEASE-COMP-CLUTCH	1	1	1	
13116	13116-0035	ROD-PUSH	1	1	1	
13187	13187-0017	PLATE-CLUTCH OPERATING	1	1	1	
92015	92015-1555	NUT,20MM	1	1	1	
92022	92022-1868	WASHER,20.3X36X3.7	1	1	1	
92026	92026-022	SPACER,25.5X47X2.5	2	2	2	
92045	92045-1235	BEARING-BALL,6001C3ML01	1	1	1	
92081	92081-1033	SPRING,CLUTCH	5	5	5	
92139	92139-0106	BUSHING	1	1	1	
92145	92145-0066	SPRING,CLUTCH RELEASE	1	1	1	
92154	92154-0079	BOLT,UPSET-WP,6X20	5	5	5	
92200	92200-1487	WASHER,12X18.5X0.5	1	1	1	

This catalog covers:

'09~'11 ER650 C9F/CAF/CBF Engine

GRID NO.

B-13

This grid covers:

Transmission

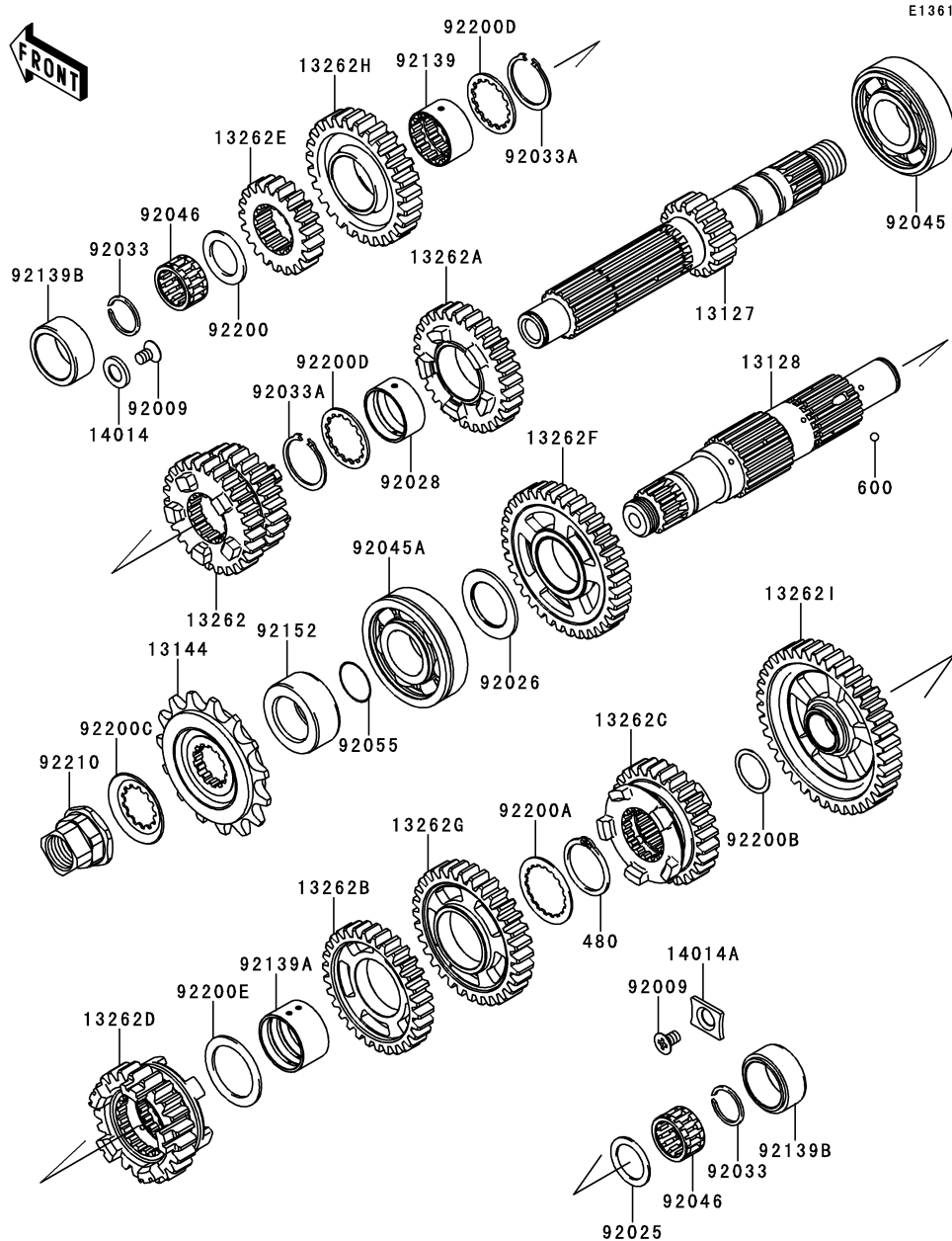

Ref. No.	Part No.	Description	Spec Code	Quantity-ER650		
				'09	'10	'11
				C9F	CAF	CBF
13127	13127-0028	SHAFT-TRANSMISSION INPUT,16T	1	1	1	
13128	13128-0020	SHAFT-TRANSMISSION OUTPUT	1	1	1	
13144	13144-0024	SPROCKET-OUTPUT,15T,#520	1	1	1	
13262	13262-0245	GEAR,INPUT 3RD&4TH,24T&27T	1	1	1	
13262A	13262-0246	GEAR,INPUT 5TH,29T	1	1	1	
13262B	13262-0251	GEAR,OUTPUT 4TH,30T	1	1	1	
13262C	13262-0252	GEAR,OUTPUT 5TH,28T	1	1	1	
13262D	13262-0253	GEAR,OUTPUT TOP,23T	1	1	1	
13262E	13262-0335	GEAR,INPUT 2ND,21T	1	1	1	
13262F	13262-0337	GEAR,OUTPUT 2ND,36T	1	1	1	
13262G	13262-0338	GEAR,OUTPUT 3RD,32T	1	1	1	
13262H	13262-0447	GEAR,INPUT TOP,27T	1	1	1	
13262I	13262-0498	GEAR,OUTPUT LOW,39T	1	1	1	
14014	14014-0019	PLATE-POSITION,9.5X17X2.3	1	1	1	
14014A	14014-0020	PLATE-POSITION,RH	1	1	1	
92009	92009-1375	SCREW,6X10	2	2	2	
92025	92025-1455	SHIM,20.3X28X1.1	1	1	1	
92026	92026-1529	SPACER,25.3X39X2.0	1	1	1	
92028	92028-1449	BUSHING,INPUT GEAR	1	1	1	
92033	92033-015	RING-SNAP,20MM	2	2	2	
92033A	92033-1037	RING-SNAP,25.9X30.6X1.2	2	2	2	
92045	92045-0042	BEARING-BALL,25X62X17	1	1	1	
92045A	92045-1224	BEARING-BALL,6305N2SH2	1	1	1	
92046	92046-1185	BEARING-NEEDLE,KMJ20X26X13.8X1	2	2	2	
92055	92055-0196	RING-O,21.5X1.5	1	1	1	
92139	92139-0107	BUSHING,INPUT TOP GEAR	1	1	1	
92139A	92139-0108	BUSHING,OUT 3RD&4TH GEAR	1	1	1	
92139B	92139-0120	BUSHING,BEARING-NEEDLE	2	2	2	
92152	92152-0300	COLLAR,25X40X17.2	1	1	1	
92200	92200-0221	WASHER,20.2X30X1.8	1	1	1	
92200A	92200-0222	WASHER,30.3X38X1.0	1	1	1	
92200B	92200-0291	WASHER,20.2X25.0X0.5	1	1	1	
92200C	92200-0506	WASHER	1	1	1	
92200D	92200-1240	WASHER,28.5X34.0X1.5	2	2	2	
92200E	92200-1278	WASHER,29.9X40X1.5	1	1	1	
92210	92210-0222	NUT,M20,L=24MM	1	1	1	
480	480J2900	CIRCLIP	1	1	1	
600	600A0500	BALL-STEEL,5/32"	3	3	3	

This catalog covers:

'09~'11 ER650 C9F/CAF/CBF Engine

GRID NO.

B-14

This grid covers:

Gear Change Drum/Shift Fork(s)

E1362

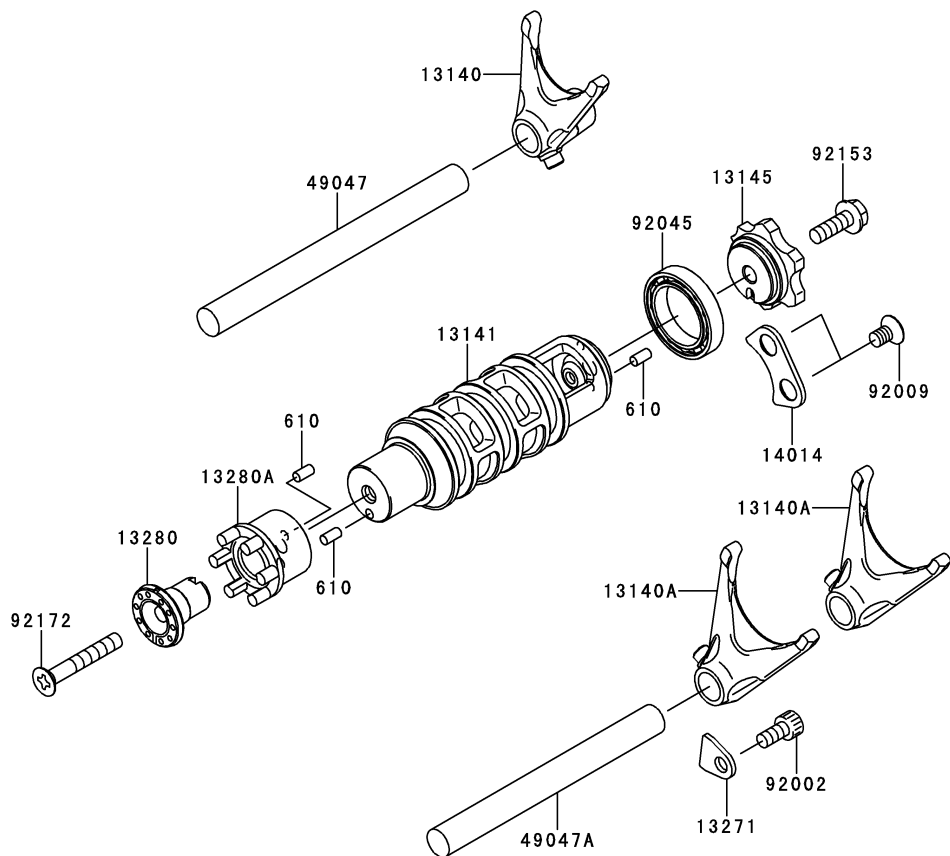

Ref. No.	Part No.	Description	Spec Code	Quantity-ER650		
				'09	'10	'11
				C9F	CAF	CBF
13140	13140-0025	FORK-SHIFT,INPUT	1	1	1	
13140A	13140-0026	FORK-SHIFT,OUTPUT	2	2	2	
13141	13141-0018	DRUM-CHANGE	1	1	1	
13145	13145-0020	CAM-CHANGE DRUM	1	1	1	
13271	13271-0626	PLATE	1	1	1	
13280	13280-0183	HOLDER,NEUTRAL SWITCH	1	1	1	
13280A	13280-0192	HOLDER	1	1	1	
14014	14014-0018	PLATE-POSITION	1	1	1	
49047	49047-0029	ROD-SHIFT,INPUT	1	1	1	
49047A	49047-0030	ROD-SHIFT,OUTPUT	1	1	1	
92002	92002-1796	BOLT,SOCKET,6X12	1	1	1	
92009	92009-1375	SCREW,6X10	2	2	2	
92045	92045-1122	BEARING-BALL,6805	1	1	1	
92153	92153-0958	BOLT,FLANGED,6X18	1	1	1	
92172	92172-0209	SCREW-CSK-CROS,6X40	1	1	1	
610	610A0408	ROLLER,4X8	3	3	3	

This catalog covers:

'09~'11 ER650 C9F/CAF/CBF Engine

GRID NO.

C-3

This grid covers:

Gear Change Mechanism

E1370

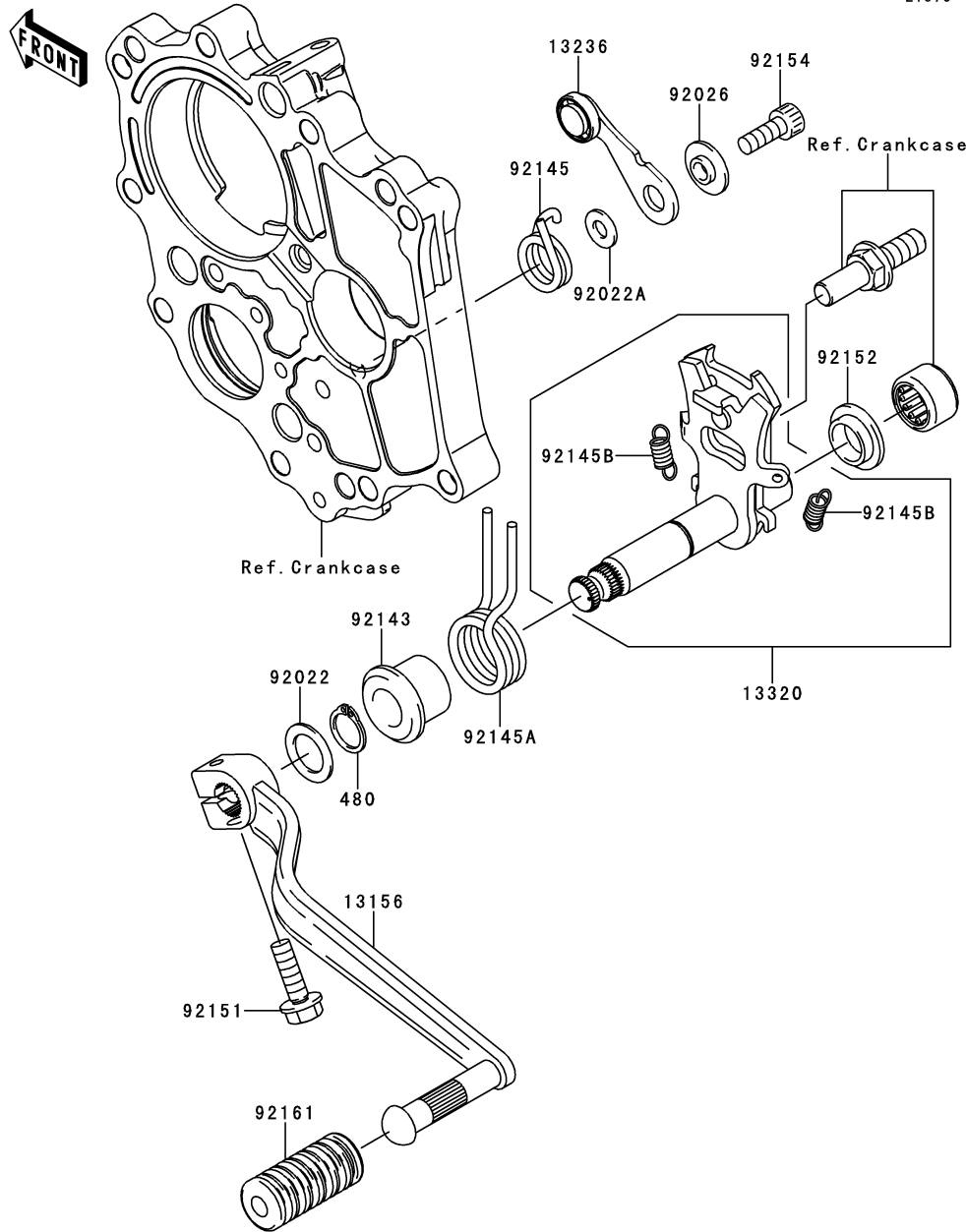

Ref. No.	Part No.	Description	Spec Code	Quantity-ER650		
				'09	'10	'11
				C9F	CAF	CBF
13156	13156-0130	LEVER-CHANGE,PEDAL	1	1	1	
13236	13236-0170	LEVER-COMP,POSITION	1	1	1	
13320	13320-0019	LEVER-ASSY,CHANGE SHAFT	1	1	1	
92022	92022-1496	WASHER,13.3X20X1	1	1	1	
92022A	92022-1827	WASHER,6X12.8X1.2	1	1	1	
92026	92026-1217	SPACER	1	1	1	
92143	92143-1498	COLLAR,RETURN SPRING	1	1	1	
92145	92145-0304	SPRING,POSITION	1	1	1	
92145A	92145-0326	SPRING,RETURN	1	1	1	
92145B	92145-0703	SPRING,5.5X0.7X18	2	2	2	
92151	92151-1226	BOLT,FLANGED,6X20	1	1	1	
92152	92152-1075	COLLAR	1	1	1	
92154	92154-0235	BOLT,SOCKET,6X16	1	1	1	
92161	92161-1300	DAMPER,CHANGE PEDAL	1	1	1	
480	480J1300	CIRCLIP-TYPE-C,13MM	1	1	1	

This catalog covers:

'09~'11 ER650 C9F/CAF/CBF Engine

GRID NO.

C-4

This grid covers:

Crankcase(1/2)

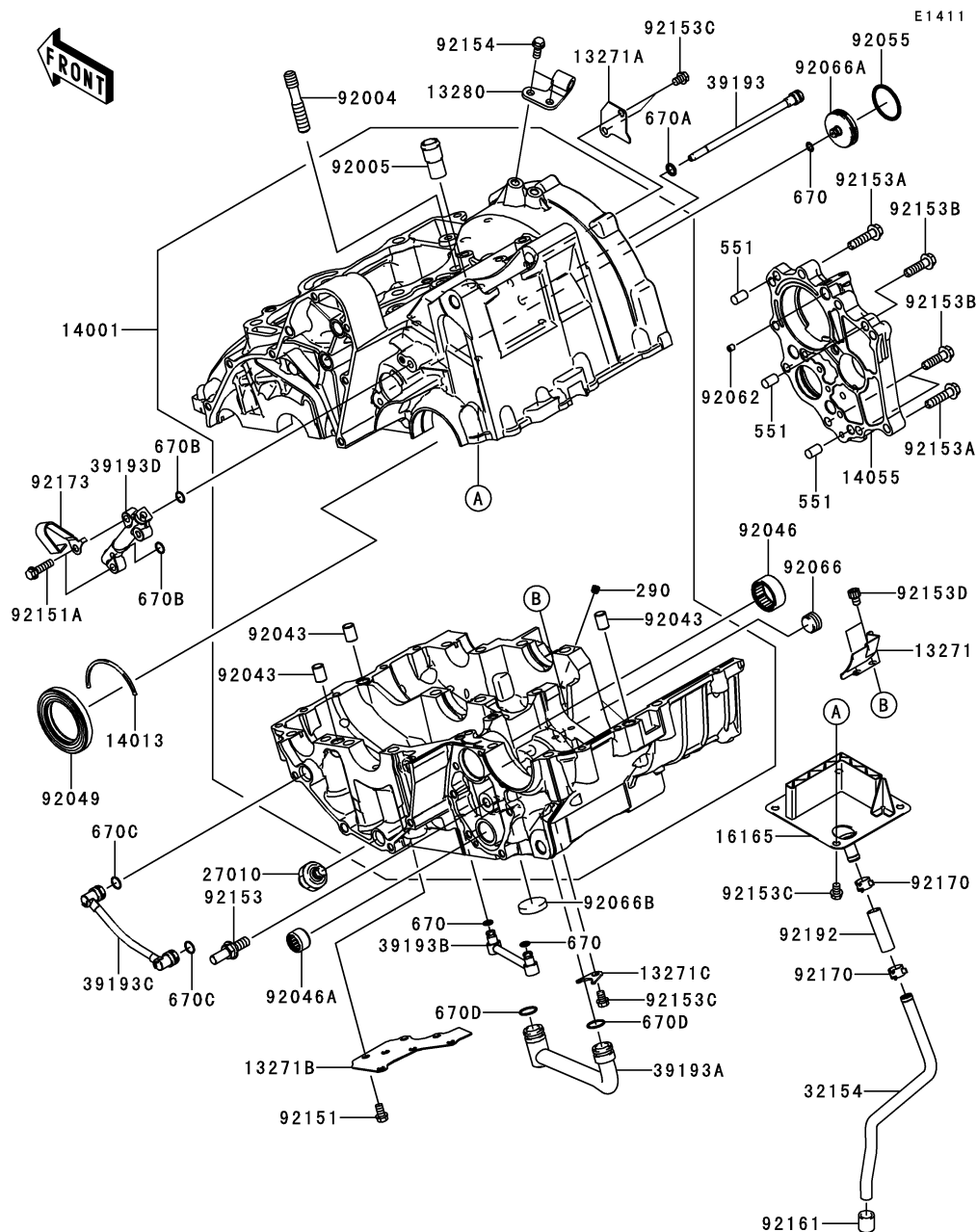

Ref. No.	Part No.	Description	Spec Code	Quantity-ER650			
				'09	'10	'11	
				C9F	CAF	CBF	
13271	13271-0575	PLATE,OIL SHIELDING	1	1	1		
13271A	13271-0577	PLATE	1	1	1		
13271B	13271-0584	PLATE	1	1	1		
13271C	13271-1187	PLATE,OIL PIPE	1	1	1		
13280	13280-0224	HOLDER,CLUTCH CABLE	1	1	1		
14001	14001-0140	SET-CRANKCASE	1	1	1		
14013	14013-1004	RING-POSITION,T=1.98	1	1	1		
14055	14055-0037	CASE-GEAR,TRANSMISSION	1	1	1		
16165	16165-0001	SEPARATOR,BREATHER	1	1	1		
27010	27010-1313	SWITCH,OIL PRESSURE	1	1	1		
32154	32154-0661	PIPE,BREATHER	1	1	1		
39193	39193-0029	PIPE-OIL	1	1	1		
39193A	39193-0031	PIPE-OIL	1	1	1		
39193B	39193-0032	PIPE-OIL	1	1	1		
39193C	39193-0033	PIPE-OIL	1	1	1		
39193D	39193-0046	PIPE-OIL	1	1	1		
92004	92004-0024	STUD,10X34.5	1	1	1		
92005	92005-1238	FITTING,BREATHER	1	1	1		
92043	92043-1037	PIN,DOWEL,10X14	3	3	3		
92046	92046-0017	BEARING-NEEDLE,24BTM3013	1	1	1		
92046A	92046-1148	BEARING-NEEDLE,HK1312	1	1	1		
92049	92049-1501	SEAL-OIL,HTC40628	1	1	1		
92055	92055-0006	RING-O,29.7X2.4	1	1	1		
92062	92062-1086	NOZZLE,5X6,SILVER	1	1	1		
92066	92066-0003	PLUG,PT3/8X10	1	1	1		
92066A	92066-0056	PLUG,INPUT SHAFT	1	1	1		
92066B	92066-0061	PLUG,25X5	1	1	1		
92151	92151-1389	BOLT,FLANGED-SMALL,6X10	6	6	6		
92151A	92151-1937	BOLT,6X22	2	2	2		
92153	92153-0530	BOLT,8X20	1	1	1		
92153A	92153-0962	BOLT,FLANGED,6X30	6	6	6		
92153B	92153-0963	BOLT,FLANGED,7X26	3	3	3		
92153C	92153-0964	BOLT,FLANGED-SMALL,6X8	7	7	7		
92153D	92153-1414	BOLT,SOCKET,6X8	2	2	2		
92154	92154-0115	BOLT,FLANGED-SMALL,6X14	2	2	2		
92161	92161-0267	DAMPER	1	1	1		
92170	92170-1167	CLAMP	2	2	2		
92173	92173-0059	CLAMP	1	1	1		
92192	92192-0225	TUBE,9X12X38	1	1	1		
290	290Q0606	SCREW-SET-SOCKET,6X6	1	1	1		

This catalog covers:

'09~'11 ER650 C9F/CAF/CBF Engine

GRID NO.

C-5

This grid covers:

Crankcase(2/2)

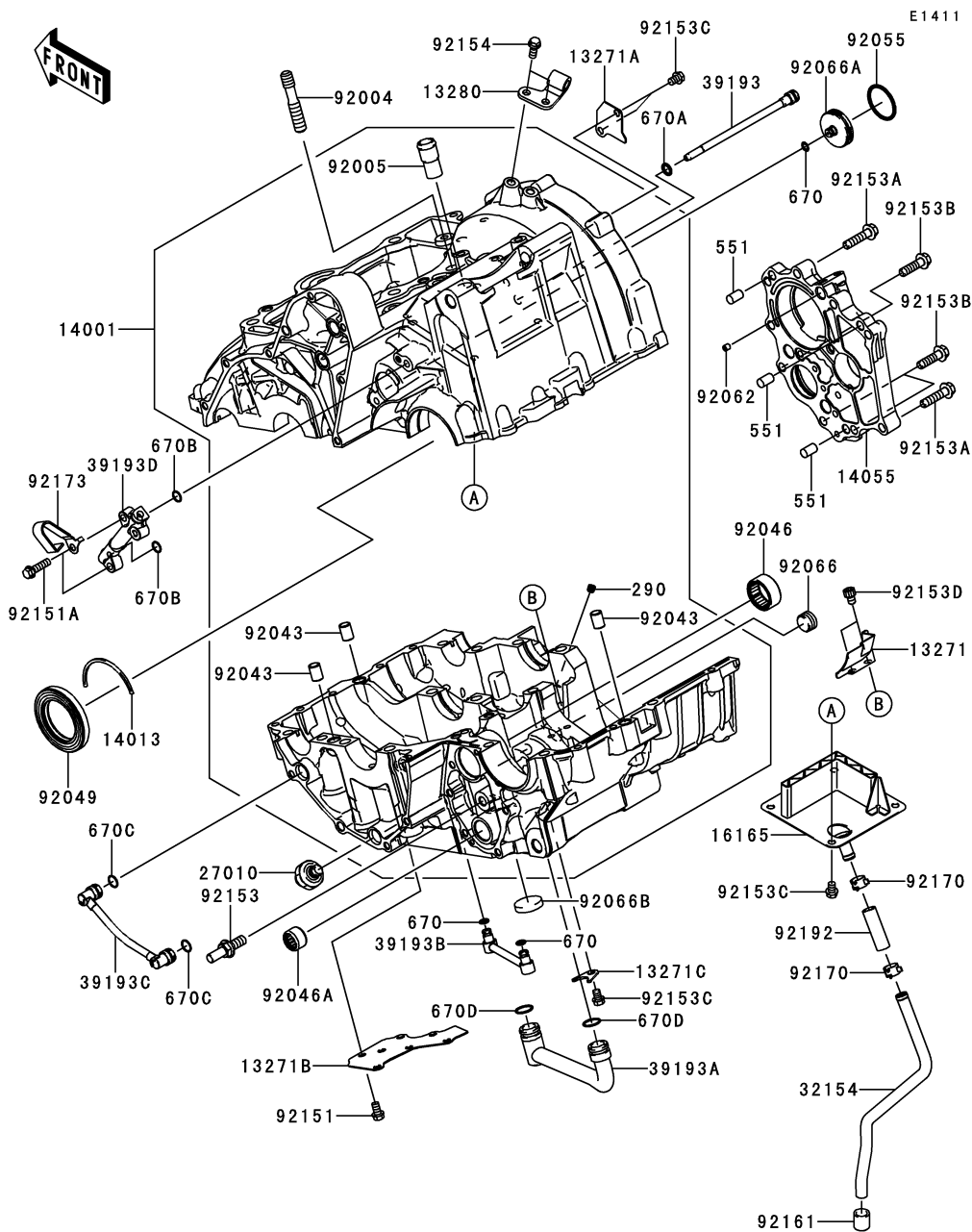

Ref. No.	Part No.	Description	Spec Code	Quantity-ER650		
				'09	'10	'11
				C9F	CAF	CBF
551	551A0814	PIN-DOWEL,8X14	3	3	3	
670	670D1505	O RING	3	3	3	
670A	670D1508	O RING,8MM	1	1	1	
670B	670D1509	O RING,9MM	2	2	2	
670C	670D1510	O RING,10MM	2	2	2	
670D	670D2014	O RING,14MM	2	2	2	

This catalog covers:

'09~'11 ER650 C9F/CAF/CBF Engine

GRID NO.

C-6

This grid covers:

Crankcase Bolt Pattern

E1412

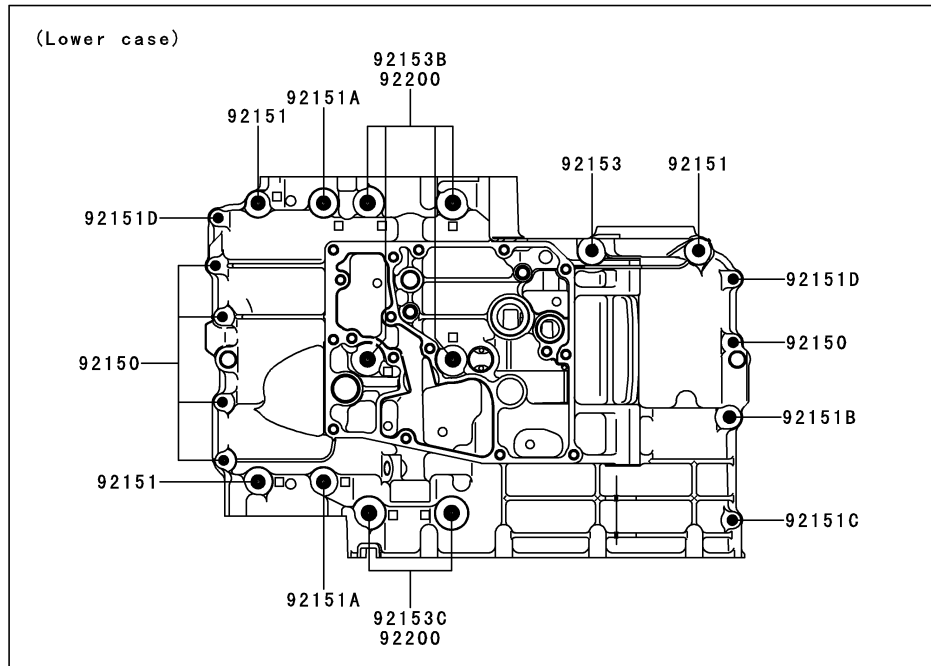
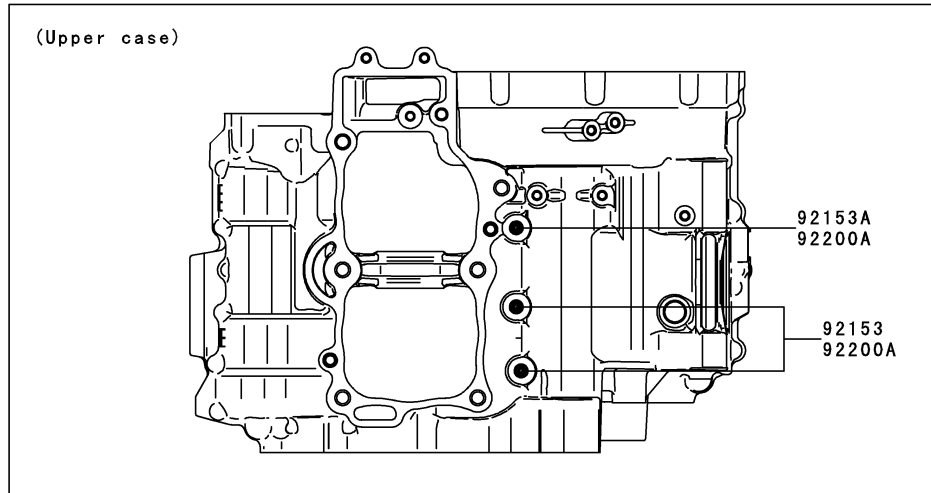

Ref. No.	Part No.	Description	Spec Code	Quantity-ER650			
				'09	'10	'11	
				C9F	CAF	CBF	
92150	92150-1301	BOLT,6X38	5	5	5		
92151	92151-1461	BOLT,8X60	3	3	3		
92151A	92151-1462	BOLT,8X73	2	2	2		
92151B	92151-1463	BOLT,8X50	1	1	1		
92151C	92151-1464	BOLT,6X32	1	1	1		
92151D	92151-1465	BOLT,6X45	2	2	2		
92153	92153-0959	BOLT,FLANGED,8X110	3	3	3		
92153A	92153-0960	BOLT,FLANGED,8X120	1	1	1		
92153B	92153-1449	BOLT,FLANGED,9X113	4	4	4		
92153C	92153-1450	BOLT,FLANGED,9X83	2	2	2		
92200	92200-0115	WASHER,9.2X19X23	6	6	6		
92200A	92200-1063	WASHER,8.5X16X1.2	3	3	3		

This catalog covers:

'09~'11 ER650 C9F/CAF/CBF Engine

GRID NO.

C-7

This grid covers:

Engine Cover(s)

E1431

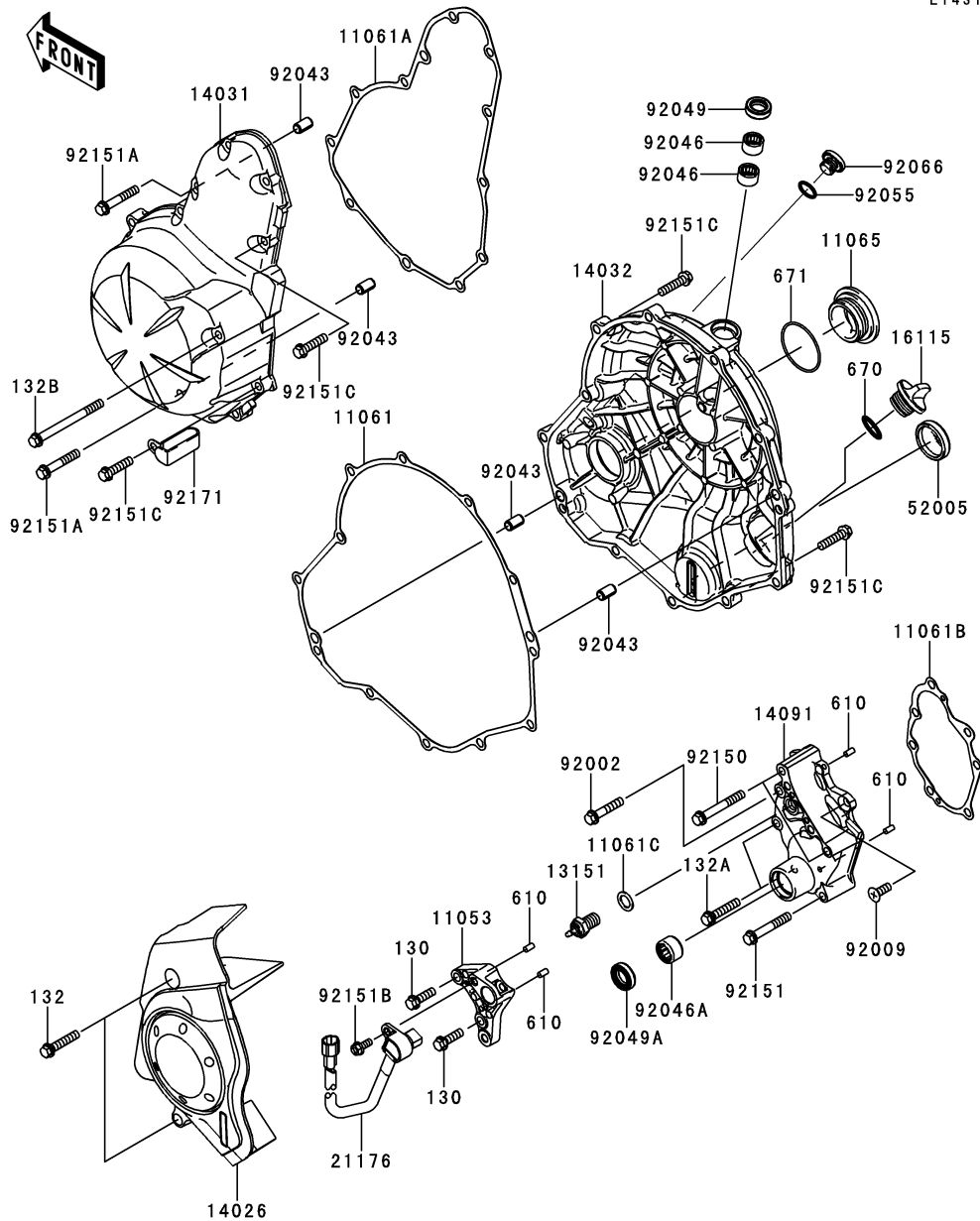

Ref. No.	Part No.	Description	Spec Code	Quantity-ER650		
				'09	'10	'11
				C9F	CAF	CBF
11053	11053-1739	BRACKET	1	1	1	
11061	11061-0164	GASKET,CLUTCH COVER	1	1	1	
11061A	11061-0165	GASKET,GENERATOR COVER	1	1	1	
11061B	11061-0166	GASKET,TRANSMISSION COVER	1	1	1	
11061C	11061-0373	GASKET,10.5X16X1	1	1	1	
11065	11065-0281	CAP	1	1	1	
13151	13151-1102	SWITCH-COMP,NEUTRAL	1	1	1	
14026	14026-0071	COVER-CHAIN	1	1	1	
14031	14031-0096	COVER-GENERATOR	1	1	1	
14032	14032-0115	COVER-CLUTCH	1	1	1	
14091	14091-1673	COVER,TRANSMISSION	1	1	1	
16115	16115-1053	CAP-OIL FILLER	1	1	1	
21176	21176-0065	SENSOR,SPEED	1	1	1	
52005	52005-0071	GAUGE,OIL LEVEL	1	1	1	
92002	92002-1534	BOLT,6X30	1	1	1	
92009	92009-1360	SCREW,6X16	1	1	1	
92043	92043-1263	PIN,6.2X8X14	4	4	4	
92046	92046-1010	BEARING-NEEDLE,HK1210	2	2	2	
92046A	92046-1148	BEARING-NEEDLE,HK1312	1	1	1	
92049	92049-1475	SEAL-OIL,CLUTCH RELEASE	1	1	1	
92049A	92049-1519	SEAL-OIL,TC13225.5	1	1	1	
92055	92055-1011	RING-O,13.0X1.9	1	1	1	
92066	92066-0131	PLUG,12X9.1	1	1	1	
92150	92150-1884	BOLT,6X45	2	2	2	
92151	92151-1131	BOLT,6X40	1	1	1	
92151A	92151-1135	BOLT,6X35	2	2	2	
92151B	92151-1305	BOLT,FLANGED,5X12	1	1	1	
92151C	92151-1930	BOLT,FLANGED-SMALL,6X25	21	21	21	
92171	92171-1873	CLAMP	1	1	1	
130	130BA0620	BOLT-FLANGED,6X20	2	2	2	
132	132BB0630	BOLT-FLANGED-SMALL,6X30	2	2	2	
132A	132BC0630	BOLT-FLANGED-SMALL,6X30	2	2	2	
132B	132BC0670	BOLT-FLANGED-SMALL,6X70	1	1	1	
610	610A0408	ROLLER,4X8	4	4	4	
670	670B2020	O RING,20MM	1	1	1	
671	671B2540	O RING,40MM	1	1	1	

This catalog covers:

'09~'11 ER650 C9F/CAF/CBF Engine

GRID NO.

C-8

This grid covers:

Oil Pan



E1434

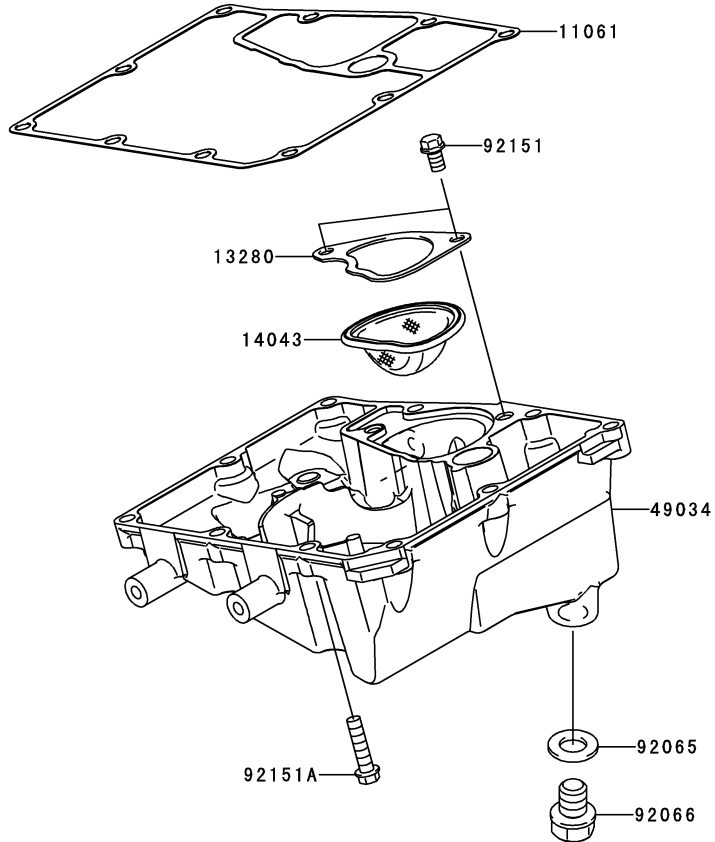

Ref. No.	Part No.	Description	Spec Code	Quantity-ER650				
				'09	'10	'11		
				C9F	CAF	CBF		
11061	11061-0167	GASKET,OIL PAN	1	1	1			
13280	13280-0134	HOLDER,OIL FILTER	1	1	1			
14043	14043-0008	FILTER,OIL(SCAVENGE)	1	1	1			
49034	49034-0030	PAN-OIL	1	1	1			
92065	92065-097	GASKET,12X22X2	1	1	1			
92066	92066-1174	PLUG,OIL DRAIN,12X15	1	1	1			
92151	92151-1389	BOLT,FLANGED-SMALL,6X10	2	2	2			
92151A	92151-1930	BOLT,FLANGED-SMALL,6X25	10	10	10			

This catalog covers:

'09~'11 ER650 C9F/CAF/CBF Engine

GRID NO.

C-9

This grid covers:

Throttle

E1510

Ref. No.	Part No.	Description	Spec Code	Quantity-ER650			
				'09	'10	'11	
				C9F	CAF	CBF	
11065	11065-0018	CAP	2	2	2		
16014	16014-0002	SCREW-PILOT AIR	2	2	2		
16073	16073-3707	INSULATOR	2	2	2		
16163	16163-0138	THROTTLE-ASSY,TTK38	1	1	1		
49033	49033-0011	NOZZLE-INJECTION	2	2	2		
92009	92009-1860	SCREW,CLAMP	1	1	1		
92039	92039-0068	RIVET	1	1	1		
92055	92055-1622	RING-O,INJECTION NOZZLE	2	2	2		
92072	92072-0012	BAND,SUB-HARNESS	2	2	2		
92170	92170-1114	CLAMP,L=150	1	1	1		
92172	92172-0064	SCREW,PIPE INJECTION	2	2	2		
92173	92173-0288	CLAMP	1	1	1		
99999	99999-0143	KIT.,25KW	1	1	1		
	(OPTION)						
99999A	99999-0271	KIT.,35KW,FOR SPAIN	1	1	1		
	(OPTION)						

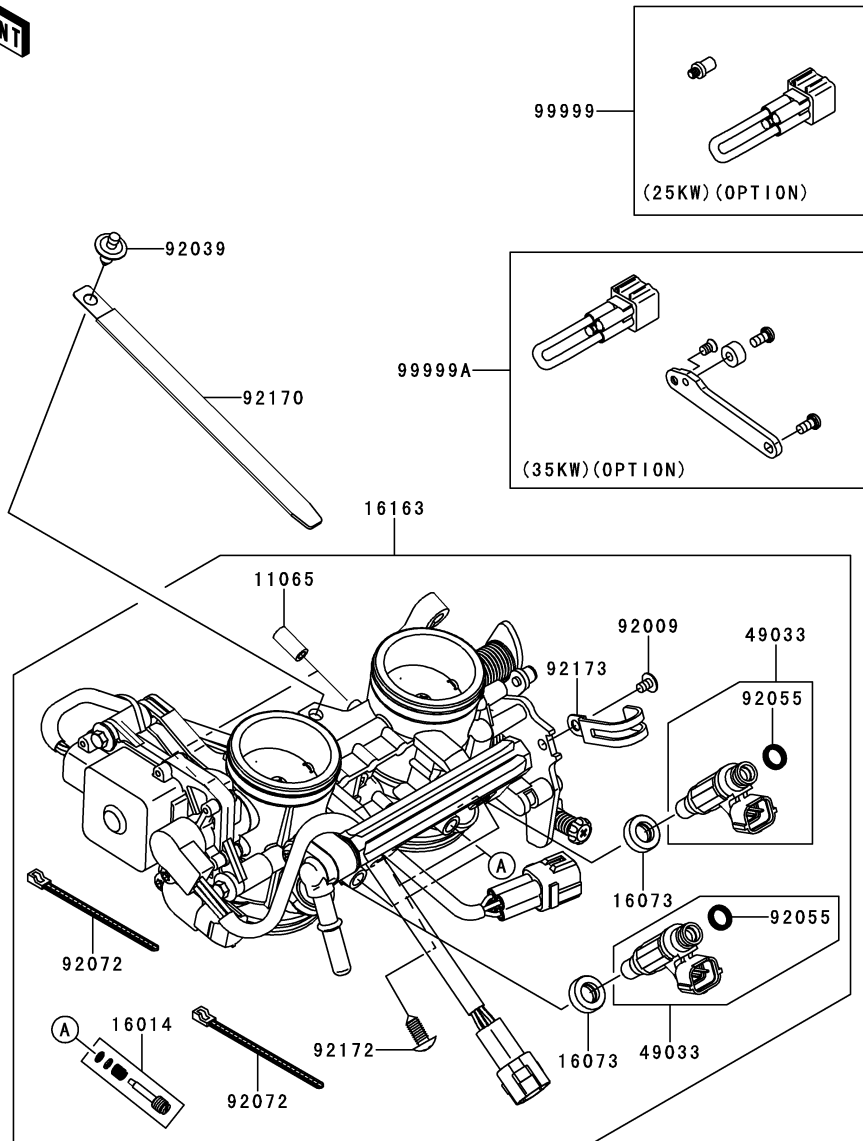

This catalog covers:

'09~'11 ER650 C9F/CAF/CBF Engine

GRID NO.

C-10

This grid covers:

Fuel Pump

E1520

Ref. No.	Part No.	Description	Spec Code	Quantity-ER650			
				'09	'10	'11	
				C9F	CAF	CBF	
49040	49040-0026	PUMP-FUEL		1	1	1	
51044	51044-0029	TUBE-ASSY		1	1	1	
92055	92055-0185	RING-O,64.6X5.7		1	1	1	
92153	92153-1295	BOLT,FLANGED,6X12		5	5	5	

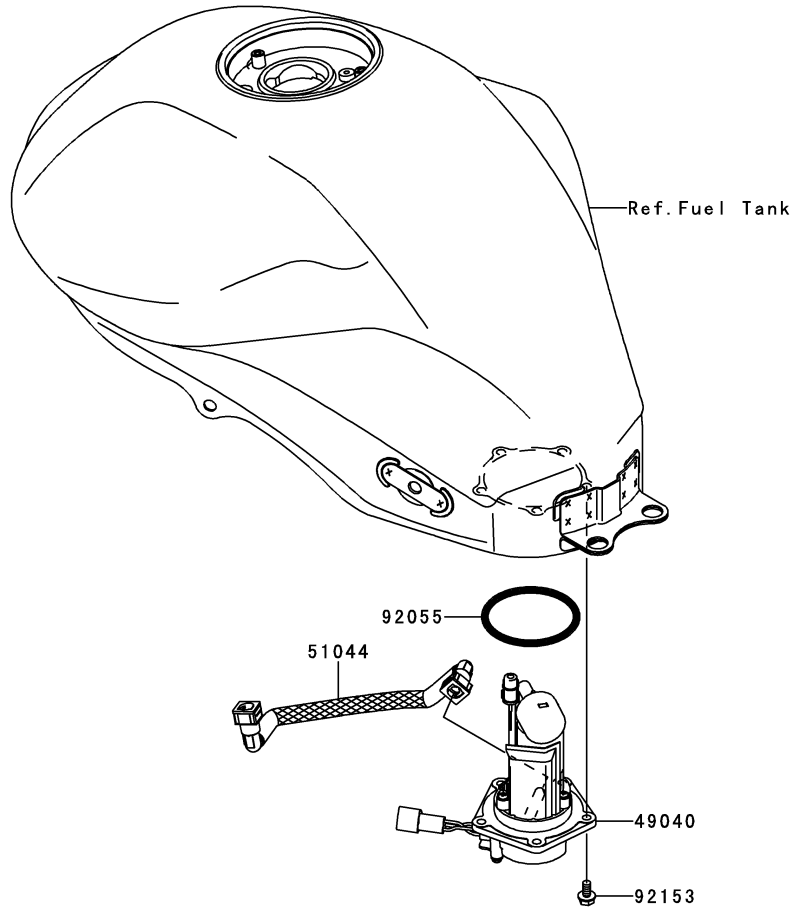

This catalog covers:

'09~'11 ER650 C9F/CAF/CBF Engine

GRID NO.

C-11

This grid covers:

Fuel Injection

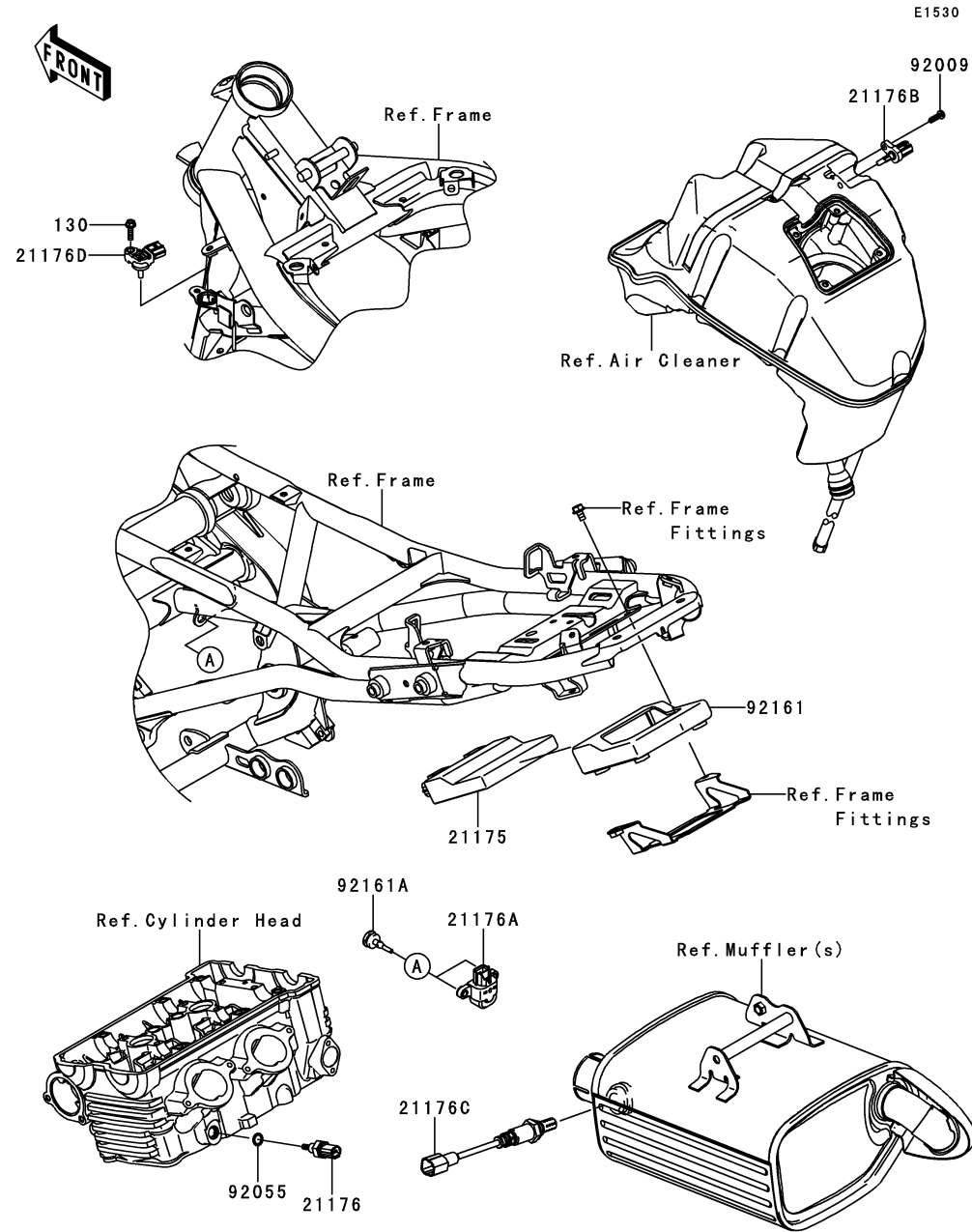

Ref. No.	Part No.	Description	Spec Code	Quantity-ER650		
				'09	'10	'11
				C9F	CAF	CBF
21175	21175-0187	CONTROL UNIT-ELECTRONIC	1	1	1	
21176	21176-0009	SENSOR,WATER TEMP	1	1	1	
21176A	21176-0026	SENSOR,VEHICLE-DOWN	1	1	1	
21176B	21176-0048	SENSOR,AIR TEMPERATURE	1	1	1	
21176C	21176-0105	SENSOR,OXYGEN	1	1	1	
21176D	21176-0111	SENSOR,PRESSURE	1	1	1	
92009	92009-1984	SCREW,TAPPING,5X16	1	1	1	
92055	92055-0016	RING-O,9.5X1.9	1	1	1	
92161	92161-0630	DAMPER,ECU	1	1	1	
92161A	92161-0839	DAMPER	2	2	2	
130	130BA0518	BOLT-FLANGED,5X18	1	1	1	

This catalog covers:

'09~'11 ER650 C9F/CAF/CBF Engine

GRID NO.

C-12

This grid covers:

Oil Pump

E1710

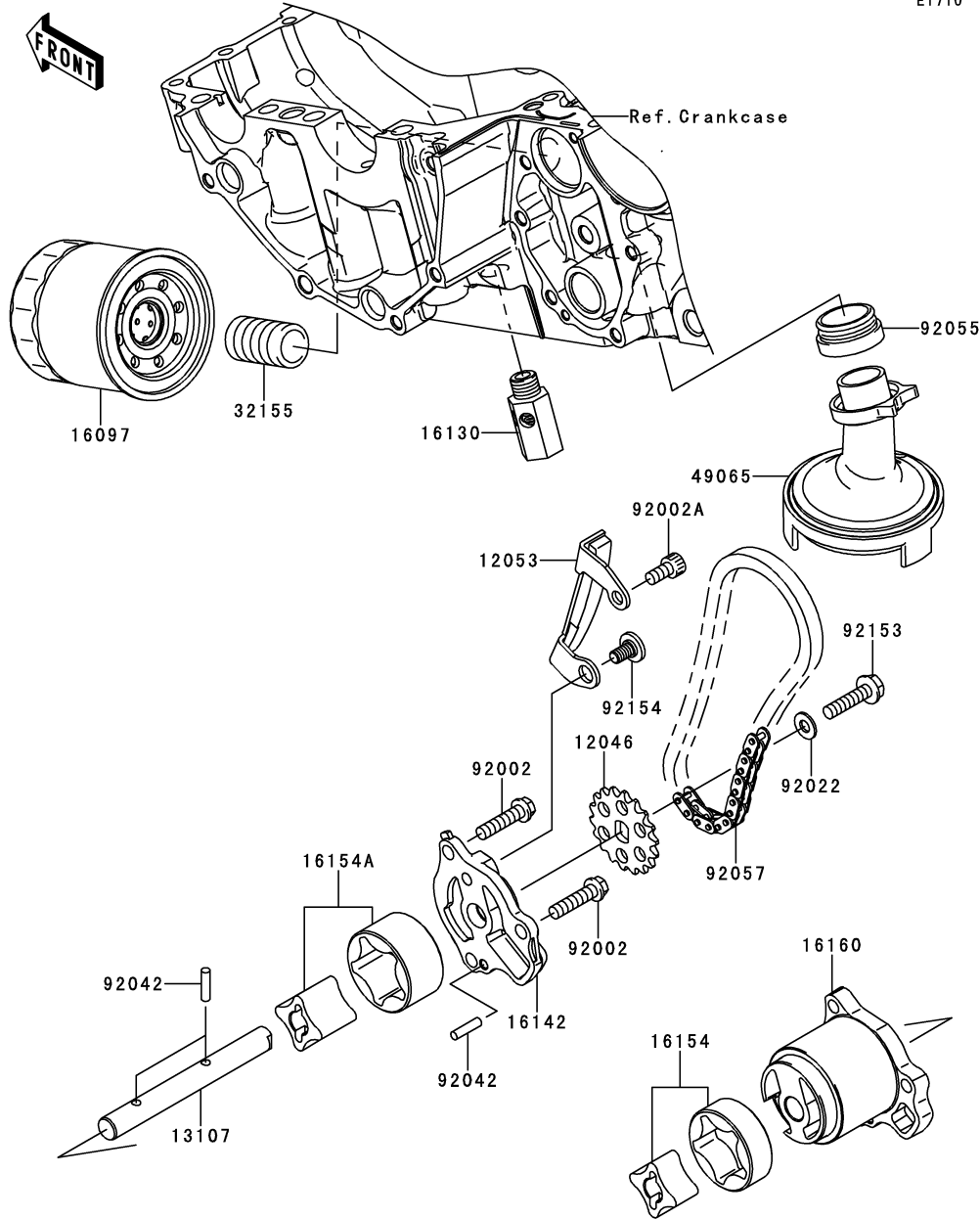

Ref. No.	Part No.	Description	Spec Code	Quantity-ER650			
				'09	'10	'11	
				C9F	CAF	CBF	
12046	12046-0040	SPROCKET,18T,BF04M	1	1	1		
12053	12053-0071	GUIDE-CHAIN	1	1	1		
13107	13107-0156	SHAFT,OIL PUMP	1	1	1		
16097	16097-0004	FILTER-ASSY-OIL	1	1	1		
16130	16130-1058	VALVE-ASSY-RELIEF	1	1	1		
16142	16142-0024	COVER-PUMP	1	1	1		
16154	16154-0037	ROTOR-PUMP,L=14	1	1	1		
16154A	16154-1115	ROTOR-PUMP,40.56X22	1	1	1		
16160	16160-0110	BODY	1	1	1		
32155	32155-0029	PIPE,OIL FILTER	1	1	1		
49065	49065-0011	FILTER-OIL	1	1	1		
92002	92002-1344	BOLT,6X25	3	3	3		
92002A	92002-1796	BOLT,SOCKET,6X12	1	1	1		
92022	92022-1827	WASHER,6X12.8X1.2	1	1	1		
92042	92042-014	PIN,DOWEL,4X15.8	3	3	3		
92055	92055-1354	RING-O,OIL FILTER	1	1	1		
92057	92057-0098	CHAIN,DID 215FD-DHA,56LE	1	1	1		
92153	92153-0952	BOLT,FLANGED,6X25	1	1	1		
92154	92154-0188	BOLT,SOCKET,6X11	1	1	1		

This catalog covers:

'09~'11 ER650 C9F/CAF/CBF Engine

GRID NO.

C-13

This grid covers:

Generator

E1810

Ref. No.	Part No.	Description	Spec Code	Quantity-ER650		
				'09	'10	'11
				C9F	CAF	CBF
13271	13271-0952	PLATE	1	1	1	
21003	21003-0042	STATOR	1	1	1	
21007	21007-0075	ROTOR	1	1	1	
21066	21066-1127	REGULATOR-VOLTAGE	1	1	1	
42034	42034-1143	COUPLING	1	1	1	
92150	92150-1433	BOLT, SOCKET, 6X30	3	3	3	
92153	92153-0951	BOLT, FLANGED, 12X45	1	1	1	
92153A	92153-1414	BOLT, SOCKET, 6X8	1	1	1	
92200	92200-0220	WASHER, 12X33X5	1	1	1	
120	120CA0818	BOLT-SOCKET, 8X18	3	3	3	
130	130BA0620	BOLT-FLANGED, 6X20	2	2	2	

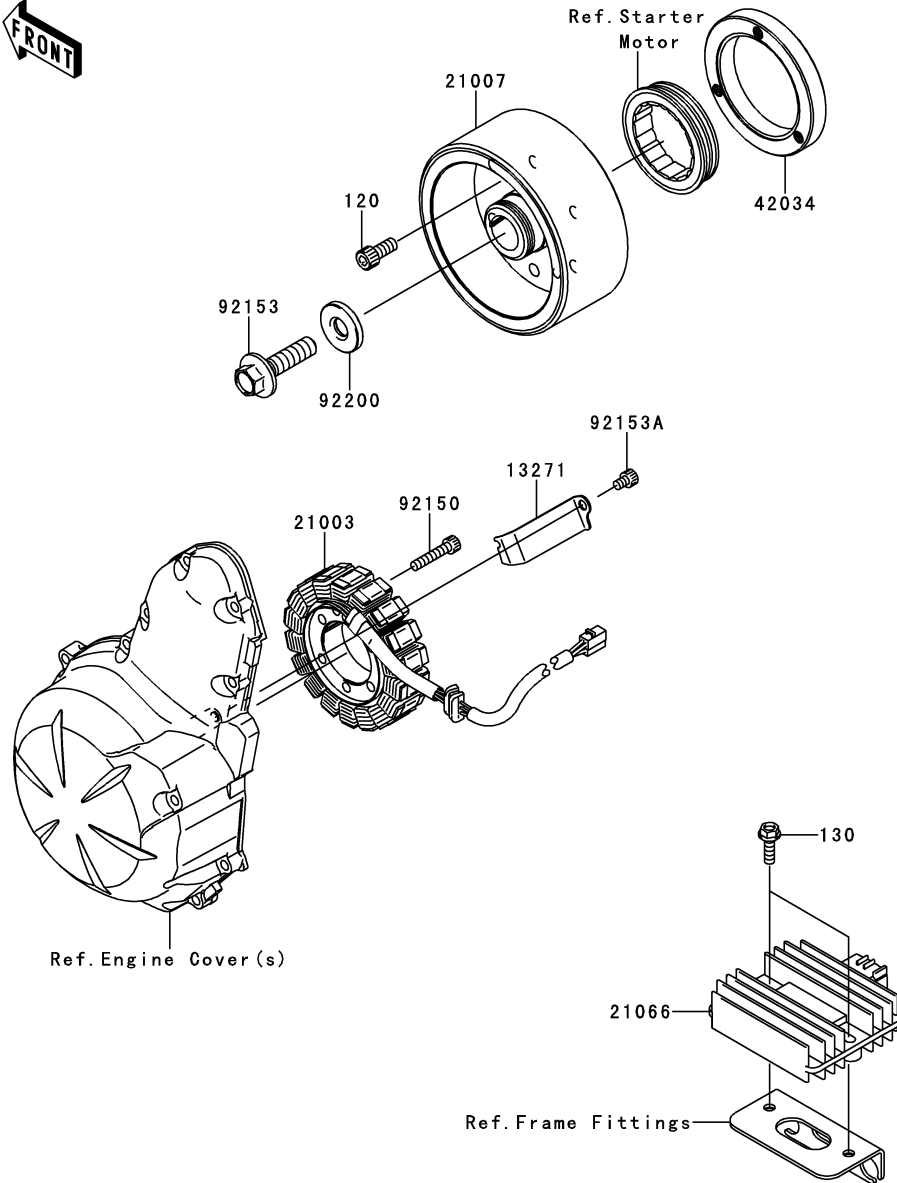

This catalog covers:

'09~'11 ER650 C9F/CAF/CBF Engine

GRID NO.

C-14

This grid covers:

Ignition System

E1830

Ref. No.	Part No.	Description	Spec Code	Quantity-ER650		
				'09	'10	'11
				C9F	CAF	CBF
21007	21007-0053	ROTOR,PULSING	1	1	1	
21171	21171-0028	COIL-ASSY-IGNITION	2	2	2	
59026	59026-0018	COIL-PULSING	1	1	1	
92070	92070-0014	PLUG-SPARK,CR9EIA(NGK)	2	2	2	
92154	92154-0187	BOLT,FLANGED,8X23	1	1	1	
92171	92171-0836	CLAMP,SPEED	1	1	1	
92200	92200-0274	WASHER,8.5X28X0.8	1	1	1	
130	130BA0512	BOLT-FLANGED,5X12	2	2	2	

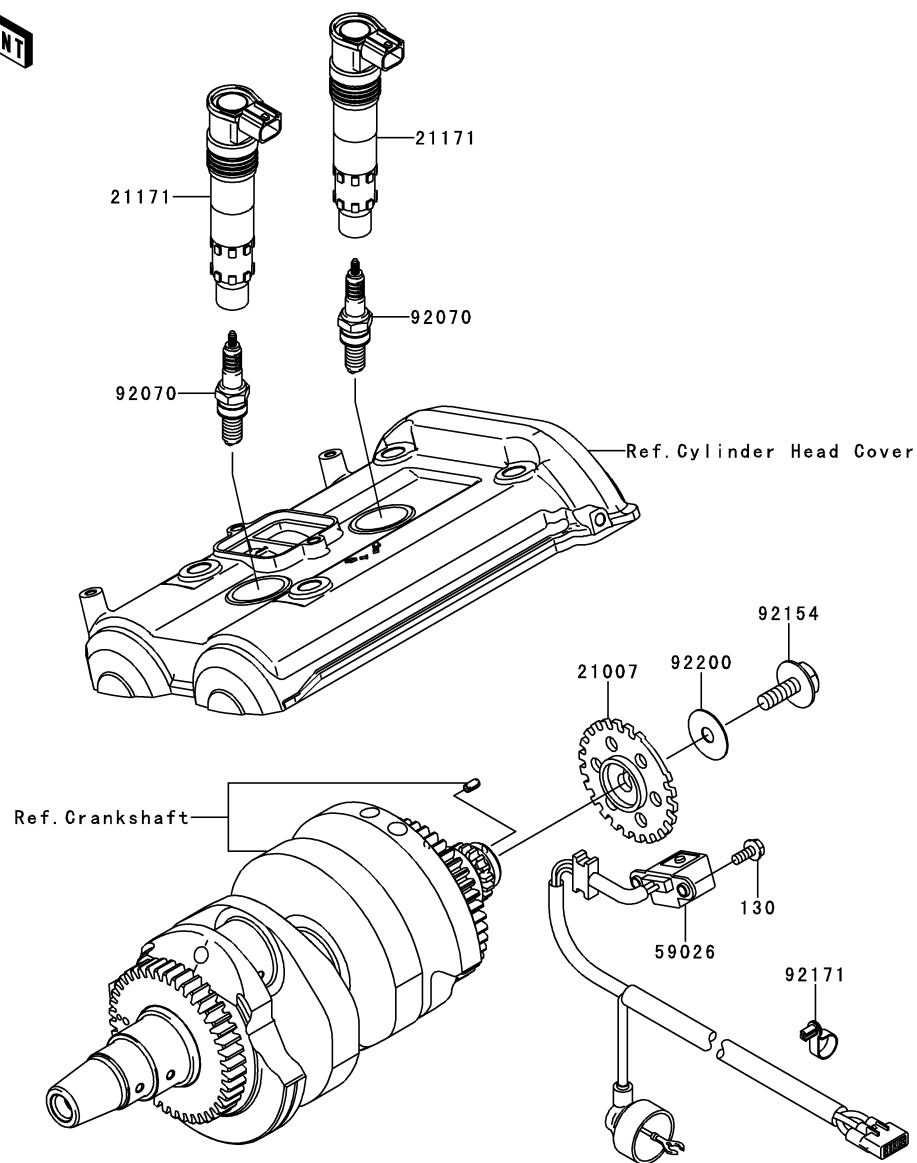

This catalog covers:

'09~'11 ER650 C9F/CAF/CBF Engine

GRID NO.

D-3

This grid covers:

Starter Motor

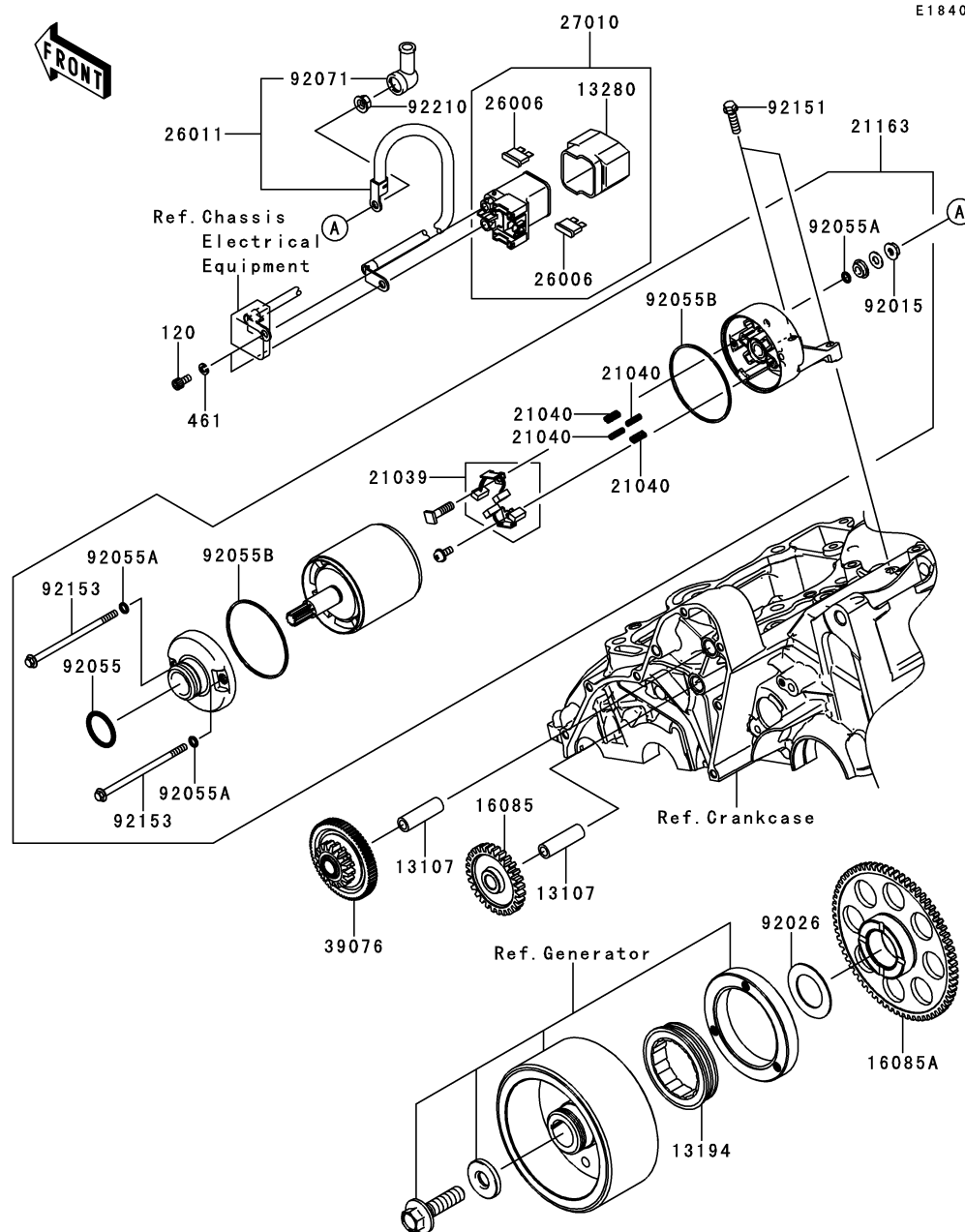

Ref. No.	Part No.	Description	Spec Code	Quantity-ER650		
				'09	'10	'11
				C9F	CAF	CBF
13107	13107-1106	SHAFT,IDLE GEAR	2	2	2	
13194	13194-1083	CLUTCH-ONEWAY	1	1	1	
13280	13280-0301	HOLDER	1	1	1	
16085	16085-0074	GEAR, IDLE,28T	1	1	1	
16085A	16085-0076	GEAR,67T	1	1	1	
21039	21039-0004	BRUSH,CARBON	1	1	1	
21040	21040-0003	SPRING-BRUSH	4	4	4	
21163	21163-0040	STARTER-ELECTRIC	1	1	1	
26006	26006-1006	FUSE, BLADE,30A, GREEN	2	2	2	
26011	26011-0205	WIRE-LEAD	1	1	1	
27010	27010-0099	SWITCH,MAGNETIC	1	1	1	
39076	39076-0006	LIMITER,16T&66T	1	1	1	
92015	92015-1476	NUT,STARTER MOTOR	1	1	1	
92026	92026-087	SPACER,29.1X47.5X1.2	1	1	1	
92055	92055-1276	RING-O	1	1	1	
92055A	92055-1370	RING-O,4.5X2.0	3	3	3	
92055B	92055-1381	RING-O,STARTER MOTOR	2	2	2	
92071	92071-0024	GROMMET	1	1	1	
92151	92151-1937	BOLT,6X22	2	2	2	
92153	92153-1783	BOLT	2	2	2	
92210	92210-0188	NUT,6MM	1	1	1	
120	120CB0610	BOLT-SOCKET,6X10	2	2	2	
461	461DB0600	WASHER-SPRING,6MM,BLACK	2	2	2	

This catalog covers:

'09~'11 ER650 C9F/CAF/CBF Engine

GRID NO.

D-4

This grid covers:

Water Pump



E3031

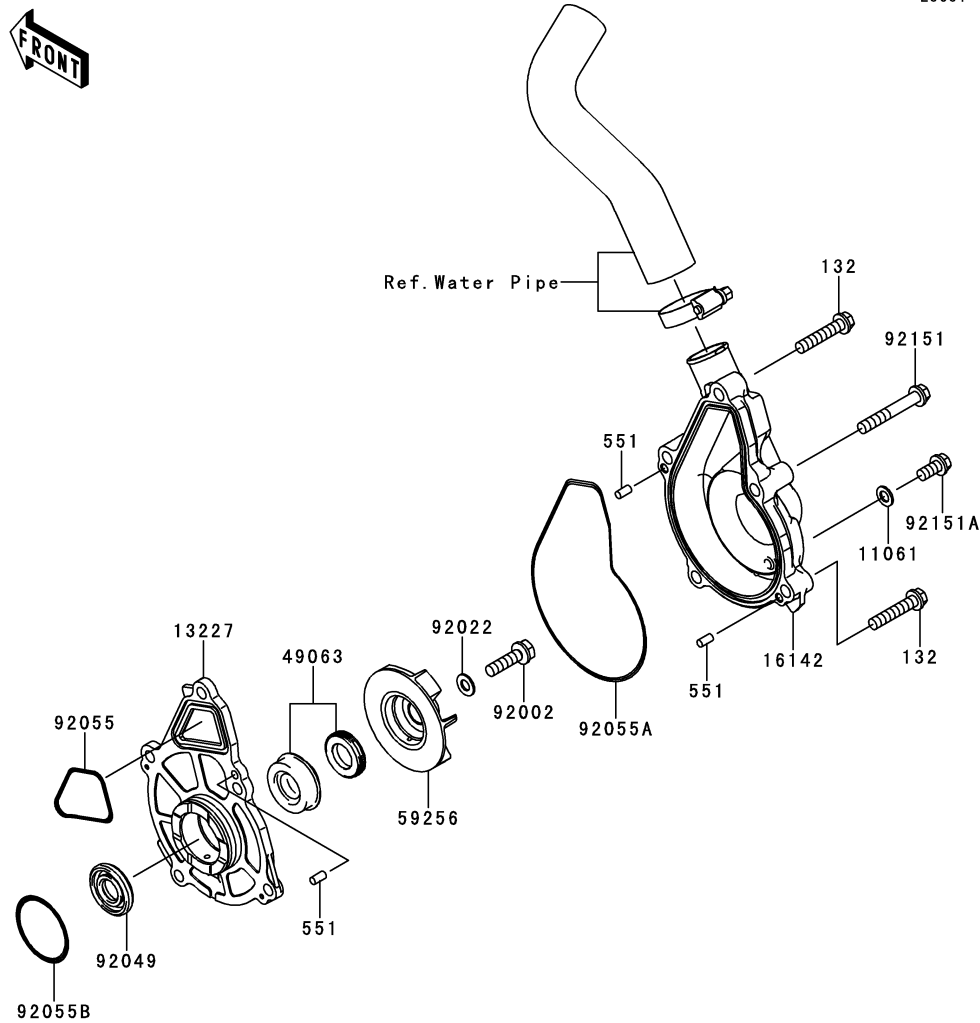

Ref. No.	Part No.	Description	Spec Code	Quantity-ER650		
				'09	'10	'11
				C9F	CAF	CBF
11061	11061-0107	GASKET	1	1	1	
13227	13227-0023	HOUSING	1	1	1	
16142	16142-0058	COVER-PUMP	1	1	1	
49063	49063-1055	SEAL-MECHANICAL,WATER	1	1	1	
59256	59256-0009	IMPELLER	1	1	1	
92002	92002-1154	BOLT,6X22	1	1	1	
92022	92022-077	WASHER,6.1X12X1	1	1	1	
92049	92049-0115	SEAL-OIL,12X28.55X5	1	1	1	
92055	92055-0082	RING-O,CASE-HOUSING	1	1	1	
92055A	92055-0083	RING-O,HOUSING-PUMP COVER	1	1	1	
92055B	92055-1155	RING-O,33.2MM	1	1	1	
92151	92151-1131	BOLT,6X40	3	3	3	
92151A	92151-1133	BOLT,6X12	1	1	1	
132	132BC0630	BOLT-FLANGED-SMALL,6X30	2	2	2	
551	551A0408	PIN-DOWEL,4X8	3	3	3	

This catalog covers:

'09~'11 ER650 C9F/CAF/CBF Engine

GRID NO.

D-5

This grid covers:

Radiator

E3032

Ref. No.	Part No.	Description	Spec Code	Quantity-ER650		
				'09	'10	'11
				C9F	CAF	CBF
39061	39061-0138	RADIATOR-ASSY	1	1	1	
49016	49016-0049	COVER-SEAL	1	1	1	
49085	49085-1078	CAP-ASSY-PRESSURE	1	1	1	
53044	53044-1185	TRIM,L=50	1	1	1	
59502	59502-0041	FAN-ASSY	1	1	1	
92015	92015-1487	NUT	3	3	3	
92027	92027-251	COLLAR,L=13.1	1	1	1	
92071	92071-1115	GROMMET	2	2	2	
92075	92075-1690	DAMPER	1	1	1	
92150	92150-1186	BOLT,6X12	3	3	3	
92150A	92150-1689	BOLT,FLANGED,6X14	2	2	2	
92161	92161-0301	DAMPER	2	2	2	
130	130BA0622	BOLT-FLANGED,6X22	1	1	1	

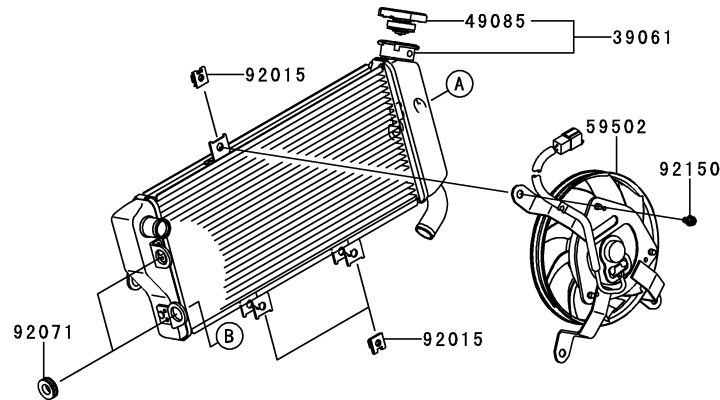
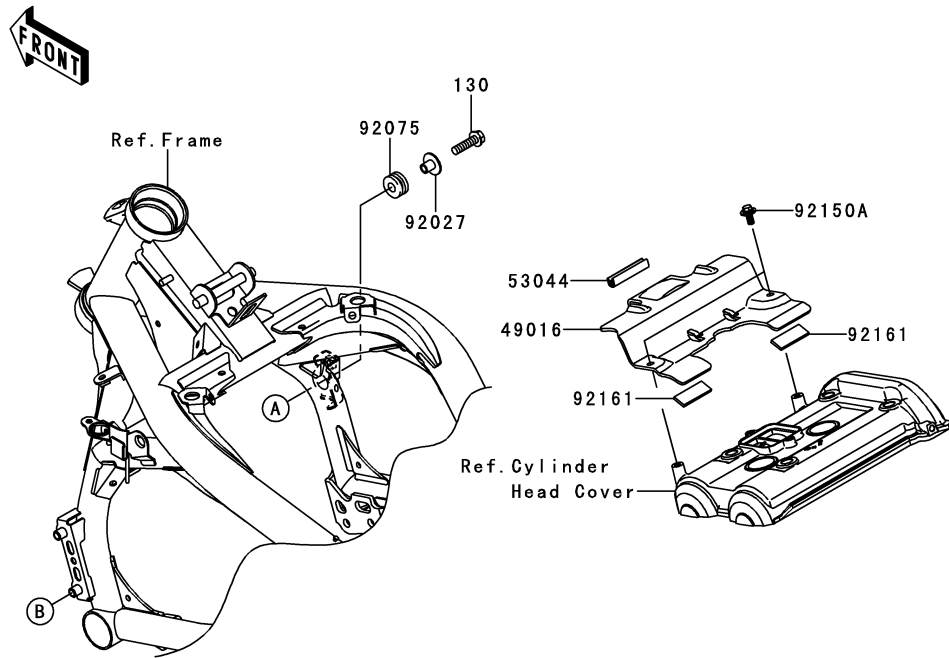

This catalog covers:

'09~'11 ER650 C9F/CAF/CBF Engine

GRID NO.

D-6

This grid covers:

Water Pipe

E3037

Ref. No.	Part No.	Description	Spec Code	Quantity-ER650		
				'09	'10	'11
				C9F	CAF	CBF
11009	11009-1145	GASKET,RESERVOIR TANK CAP	1	1	1	
11012	11012-1084	CAP	1	1	1	
16160	16160-0181	BODY,THERMO	1	1	1	
39062	39062-0254	HOSE-COOLING,HEAD-RAD.	1	1	1	
39062A	39062-0255	HOSE-COOLING,RAD.-RESERVOIR	1	1	1	
39062B	39062-0265	HOSE-COOLING,W.PUMP-RAD	1	1	1	
43078	43078-0052	RESERVOIR	1	1	1	
49054	49054-0001	THERMOSTAT	1	1	1	
92055	92055-0160	RING-O,44.7X2.4	1	1	1	
92150	92150-1340	BOLT,6X14	2	2	2	
92154	92154-0118	BOLT,FLANGED-SMALL,6X20	3	3	3	
92171	92171-0261	CLAMP	2	2	2	
92171A	92171-0337	CLAMP	2	2	2	
92171B	92171-1992	CLAMP,10.5X8X0.7	2	2	2	
92192	92192-0679	TUBE,BREATHER	1	1	1	

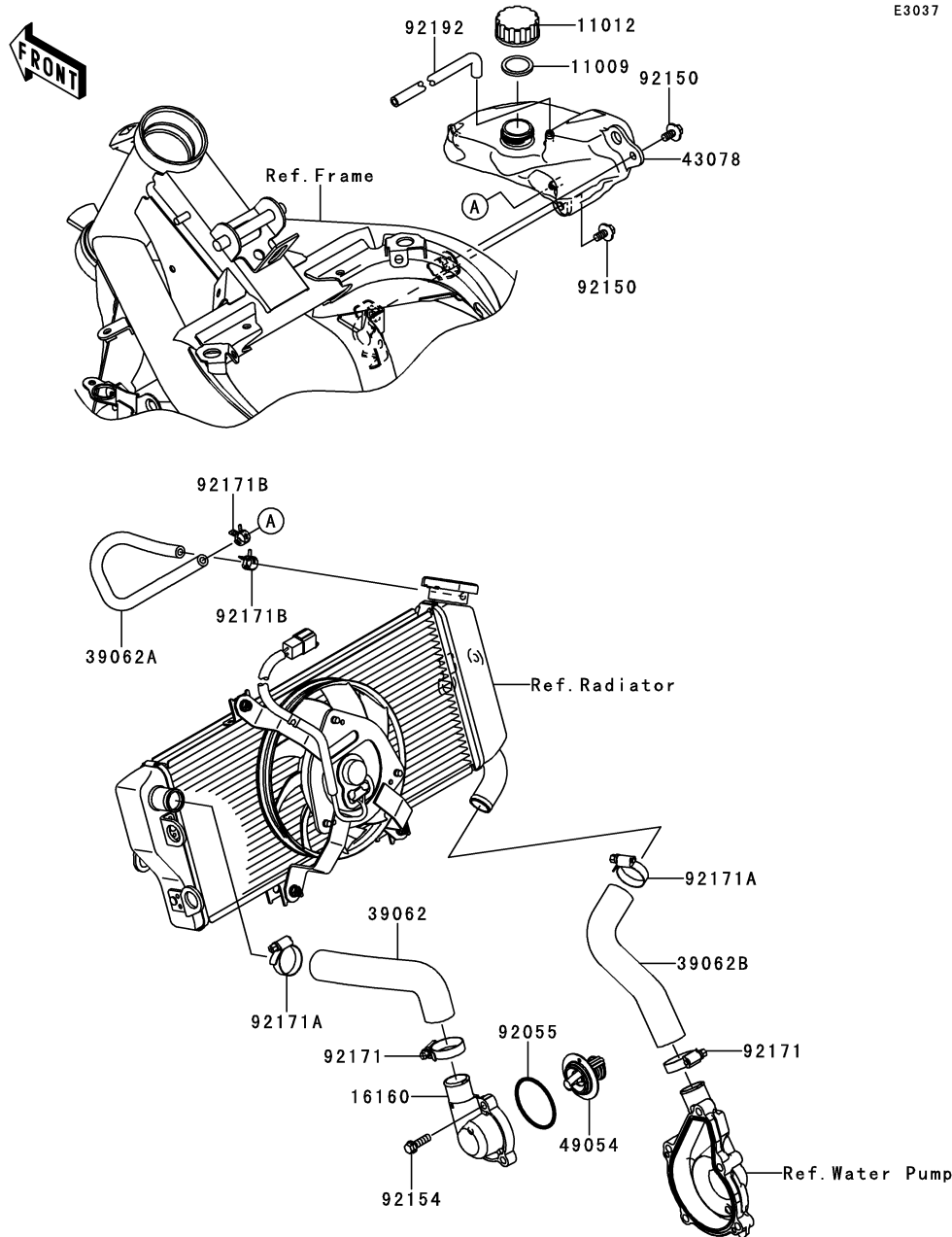

This catalog covers:

'09~'11 ER650 C9F/CAF/CBF Chassis

GRID NO.

E-3

This grid covers:

Frame

F2120

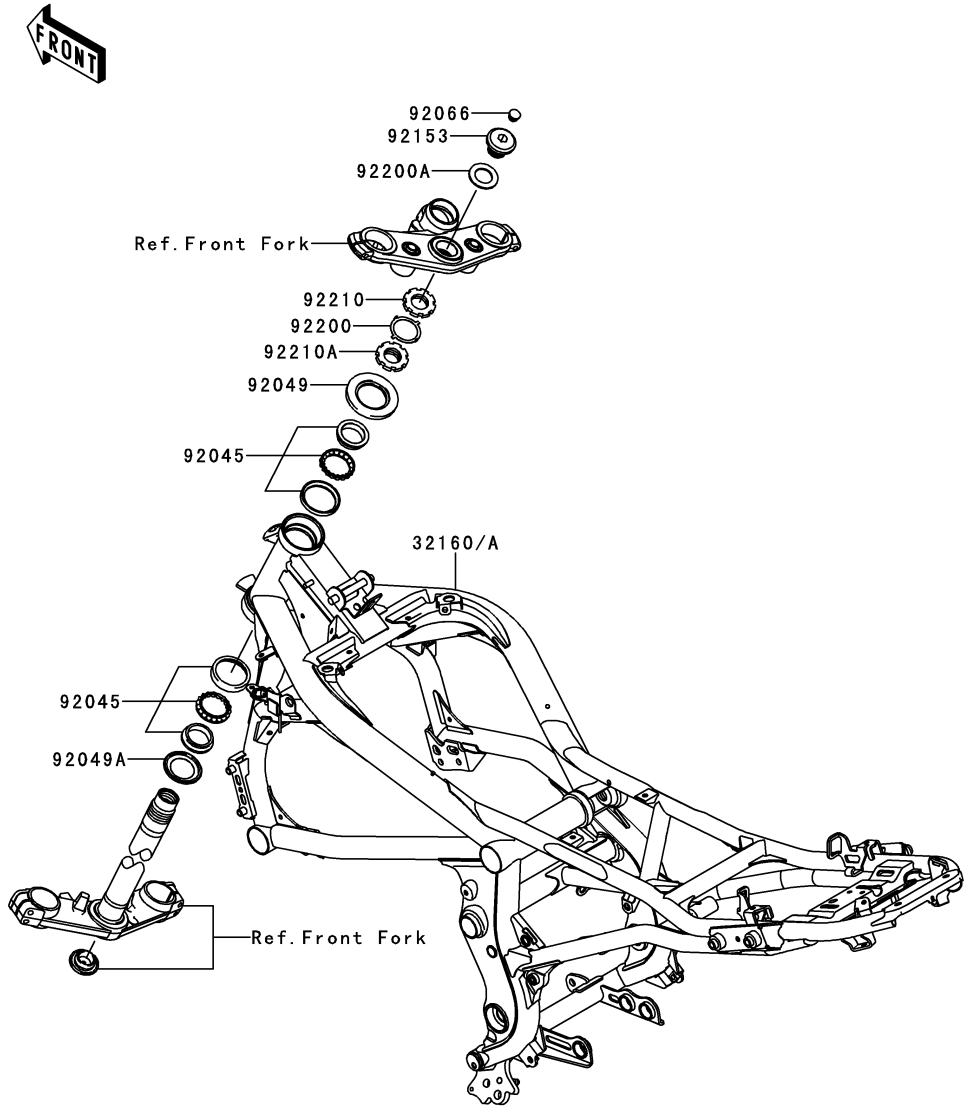

Ref. No.	Part No.	Description	Spec Code	Quantity-ER650		
				'09	'10	'11
				C9F	CAF	CBF
32160	32160-0318-10	FRAME-COMP,BLACK		1	1	
32160A	32160-0318-26M	FRAME-COMP,F.M.GRAY		1		
92045	92045-1384	BEARING-BALL,SF07A17PX1V1		2	2	2
92049	92049-0131	SEAL-OIL		1	1	1
92049A	92049-0137	SEAL-OIL		1	1	1
92066	92066-0071	PLUG		1	1	1
92153	92153-0474	BOLT,26MM		1	1	1
92200	92200-0036	WASHER		1	1	1
92200A	92200-0081	WASHER,27X42X2.3		1	1	1
92210	92210-0534	NUT,STEERING STEM,35MM		1	1	1
92210A	92210-0535	NUT,STEERING STEM,35MM		1	1	1

This catalog covers:

'09~'11 ER650 C9F/CAF/CBF Chassis

GRID NO.

E-4

This grid covers:

Engine Mount

F2122

Ref. No.	Part No.	Description	Spec Code	Quantity-ER650			
				'09	'10	'11	
				C9F	CAF	CBF	
32190	32190-0189	BRACKET-ENGINE,RH	1	1	1		
32190A	32190-0381	BRACKET-ENGINE,LH	1	1	1		
92015	92015-1188	NUT,LOCK,10MM,BLACK	2	2	2		
92092	92092-0021	BUSHING-RUBBER	4	4	4		
92152	92152-0740	COLLAR,11X26X50.8	1	1	1		
92153	92153-0823	BOLT,FLANGED,10X47	1	1	1		
92153A	92153-0995	BOLT,FLANGED,8X20	3	3	3		
92153B	92153-1428	BOLT,FLANGED,10X170	1	1	1		
92154	92154-0083	BOLT,FLANGED,10X100	1	1	1		
92154A	92154-0138	BOLT,FLANGED,10X237	1	1	1		
92210	92210-1081	NUT,LOCK,FLANGED,10MM	2	2	2		
132	132BB0822	BOLT-FLANGED-SMALL,8X22	1	1	1		

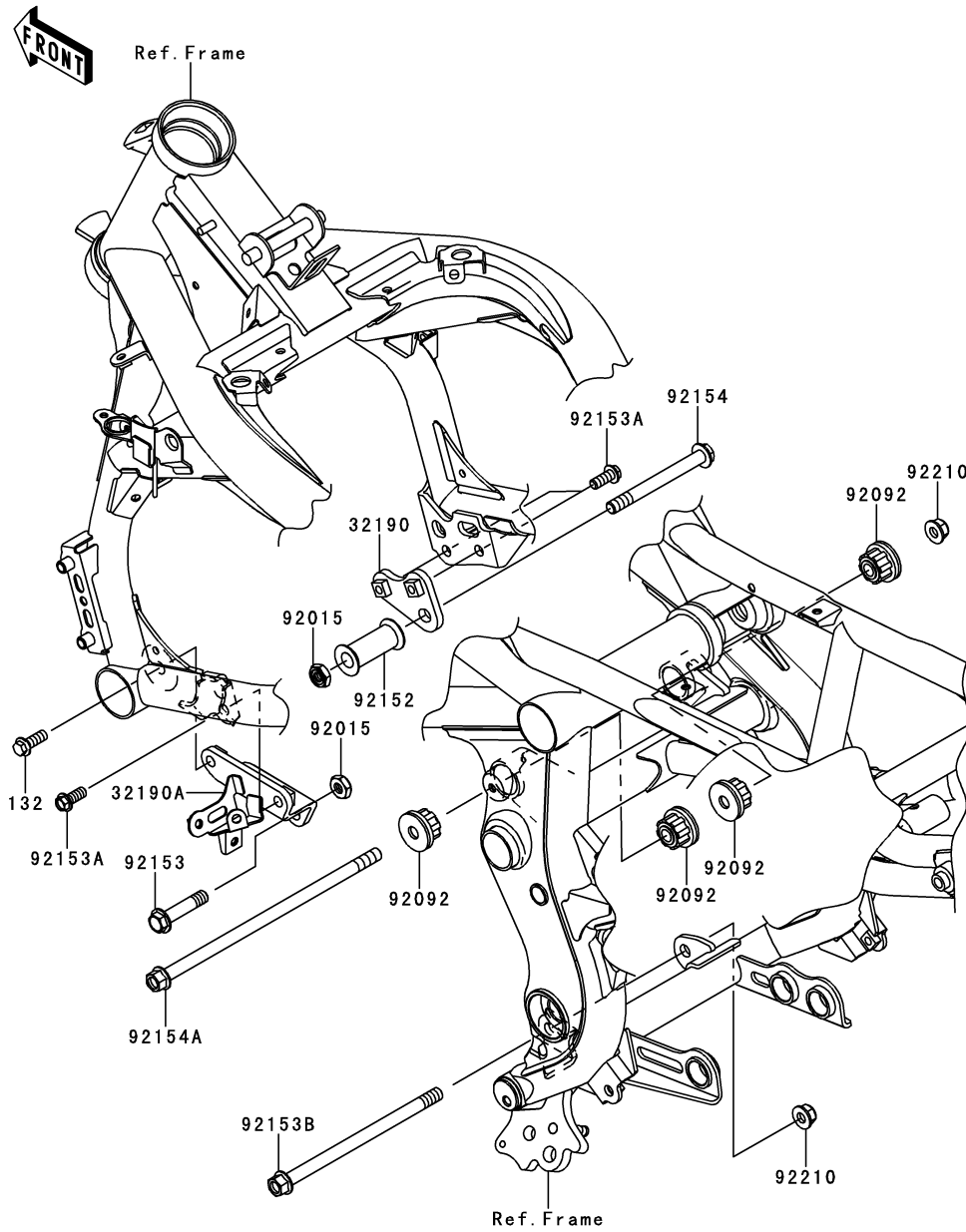

This catalog covers:

'09~'11 ER650 C9F/CAF/CBF Chassis

GRID NO.

E-5

This grid covers:

Frame Fittings

F2131

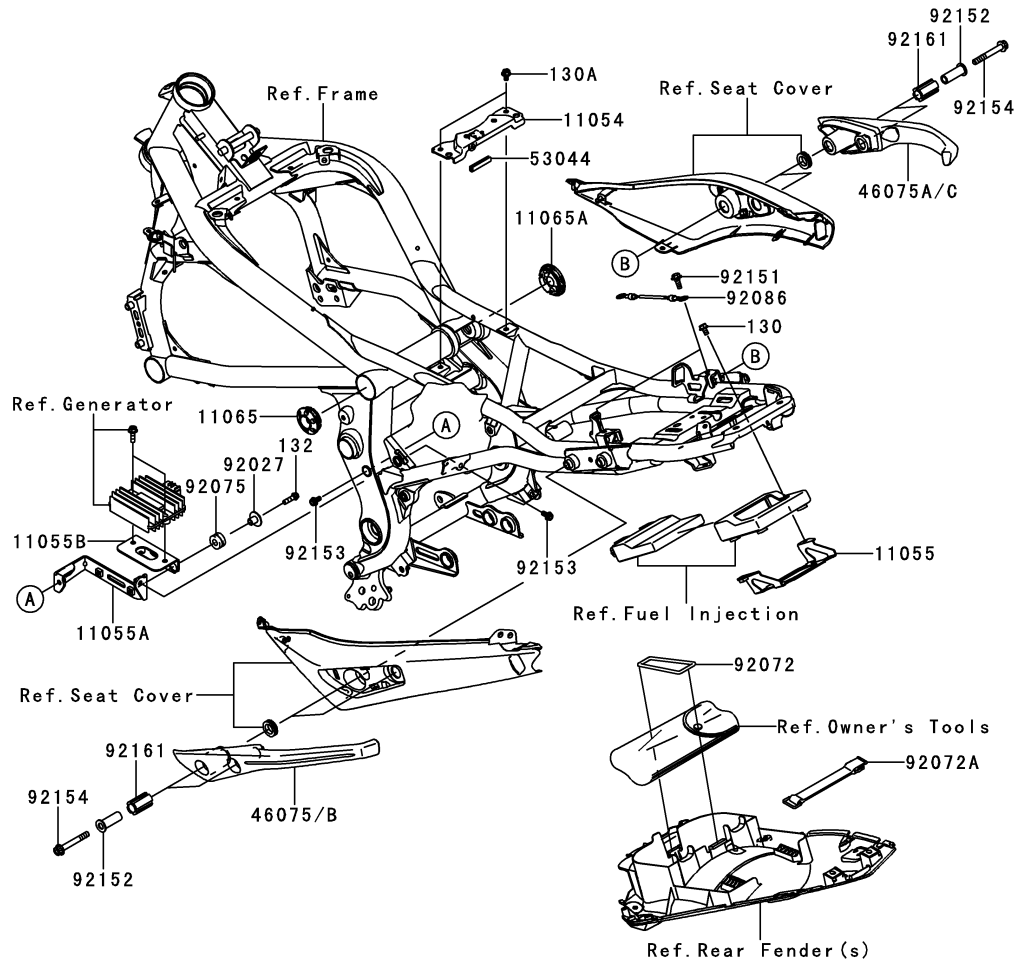

Ref. No.	Part No.	Description	Spec Code	Quantity-ER650			
				'09	'10	'11	
				C9F	CAF	CBF	
11054	11054-0248	BRACKET,FUEL TANK	1	1	1		
11055	11055-0584	BRACKET,ECU	1	1	1		
11055A	11055-1131	BRACKET,REGULATOR	1	1	1		
11055B	11055-1137	BRACKET,REGULATOR	1	1	1		
11065	11065-0257-458	CAP,PIVOT COVER,LH,P.SILVER	1	1	1		
11065A	11065-0264-458	CAP,PIVOT COVER,RH,P.SILVER	1	1	1		
46075	46075-0078	GRIP,TANDEM,LH	1				
46075A	46075-0079	GRIP,TANDEM,RH	1				
46075B	46075-0097	GRIP,TANDEM,LH		1	1		
46075C	46075-0098	GRIP,TANDEM,RH		1	1		
53044	53044-1174	TRIM,L=40	1	1	1		
92027	92027-1450	COLLAR,L=13.1,BLACK	2	2	2		
92072	92072-0108	BAND,TOOL	1	1	1		
92072A	92072-1203	BAND,L=150	1	1	1		
92075	92075-209	DAMPER	2	2	2		
92086	92086-1075	WIRE,L=150	2	2	2		
92151	92151-1703	BOLT,FLANGED,6X13	2	2	2		
92152	92152-0707	COLLAR	4	4	4		
92153	92153-1517	BOLT,SOCKET,6X16	2	2	2		
92154	92154-0259	BOLT,SOCKET,8X60	4	4	4		
92161	92161-0663	DAMPER	4	4	4		
130	130BA0612	BOLT-FLANGED,6X12	2	2	2		
130A	130BB0610	BOLT-FLANGED,6X10	2	2	2		
132	132BB0622	BOLT-FLANGED-SMALL,6X22	2	2	2		

This catalog covers:

'09~'11 ER650 C9F/CAF/CBF Chassis

GRID NO.

E-6

This grid covers:

Swingarm

F2141

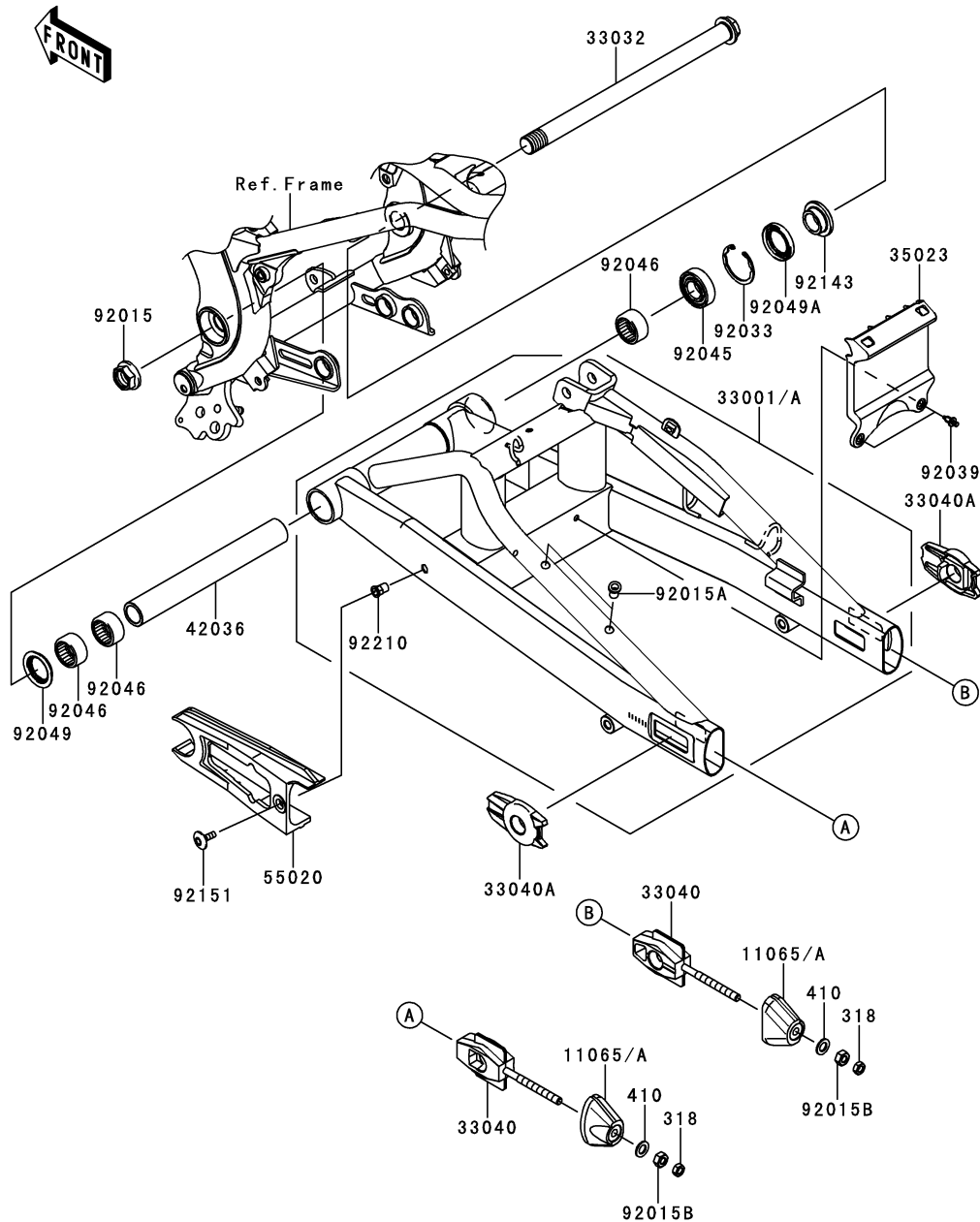

Ref. No.	Part No.	Description	Spec Code	Quantity-ER650			
				'09	'10	'11	
				C9F	CAF	CBF	
11065	11065-0258-10	CAP,CHAIN ADJUSTER,BLACK		2	2		
11065A	11065-0258-26M	CAP,CHAIN ADJUSTER,F.M.GRAY		2			
33001	33001-0161-10	ARM-COMP-SWING,BLACK			1	1	
33001A	33001-0161-26M	ARM-COMP-SWING,F.M.GRAY			1		
33032	33032-1142	SHAFT-SWING ARM		1	1	1	
33040	33040-0025	ADJUSTER-CHAIN,INNER		2	2	2	
33040A	33040-0026-458	ADJUSTER-CHAIN,OUTER,P.SILVER		2	2	2	
35023	35023-0149	FENDER-REAR,SWING ARM		1	1	1	
42036	42036-0066	SLEEVE,SWING ARM,L=219.5		1	1	1	
55020	55020-0192	GUARD,CHAIN		1	1	1	
92015	92015-1724	NUT,FLANGED,20MM		1	1	1	
92015A	92015-1759	NUT,POP,6MM		2	2	2	
92015B	92015-1959	NUT,8MM		2	2	2	
92033	92033-1041	RING-SNAP,42MM		1	1	1	
92039	92039-0023	RIVET		2	2	2	
92045	92045-0017	BEARING-BALL,6004UL11		1	1	1	
92046	92046-0008	BEARING-NEEDLE,7E-HVS 28X34X17		3	3	3	
92049	92049-0132	SEAL-OIL		1	1	1	
92049A	92049-0138	SEAL-OIL		1	1	1	
92143	92143-1727	COLLAR,SWING ARM,RH,L=12.5		1	1	1	
92151	92151-1149	BOLT,SOCKET,6X18		1	1	1	
92210	92210-1397	NUT,POP,6MM,L=15		1	1	1	
318	318AB0800	NUT-HEX-SMALL		2	2	2	
410	410AB0800	WASHER-PLAIN-SMALL,8MM,BLACK		2	2	2	

This catalog covers:

'09~'11 ER650 C9F/CAF/CBF Chassis

GRID NO.

E-7

This grid covers:

Suspension/Shock Absorber

F2151

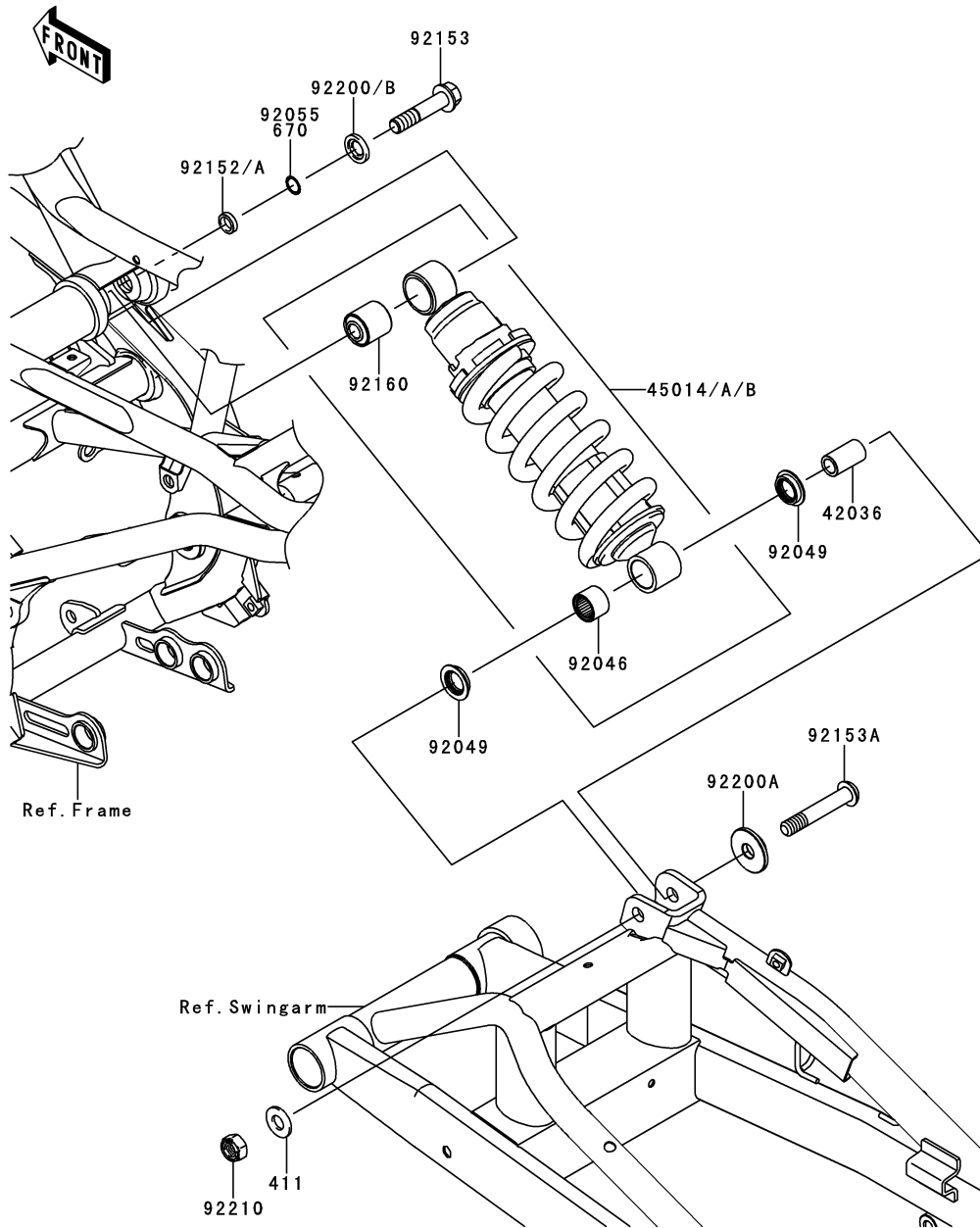

Ref. No.	Part No.	Description	Spec Code	Quantity-ER650			
				'09	'10	'11	
				C9F	CAF	CBF	
42036	42036-0024	SLEEVE,12.1X18X32	1	1	1		
45014	45014-0223-458	SHOCKABSORBER,P.SILVER	1				
45014A	45014-0298-VM	SHOCKABSORBER,S.RED		1			
45014B	45014-0298-458	SHOCKABSORBER,P.SILVER		1	1		
92046	92046-1272	BEARING-NEEDLE,SFYZM182417	1	1	1		
92049	92049-0133	SEAL-OIL	2	2	2		
92055	92055-1563	RING-O,ID=11.4	1				
	(JKAER650CCDA13242)						
92152	92152-0662	COLLAR,12.1X16.8X2.1	1				
	(JKAER650CCDA13242)						
92152A	92152-0811	COLLAR,12.1X16.8X4.4	1	1	1		
	(JKAER650CCDA13243 -)						
92153	92153-1766	BOLT,FLANGED,12X55	1	1	1		
92153A	92153-1985	BOLT,SOCKET,12X70	1	1	1		
92160	92160-1161	DAMPER,SHOCKABSORBER	1	1	1		
92200	92200-0432	WASHER,12.5X24X1.6	1				
	(JKAER650CCDA13242)						
92200A	92200-0484	WASHER	1	1	1		
92200B	92200-0519	WASHER,12.5X24X3.2	1	1	1		
	(JKAER650CCDA13243 -)						
92210	92210-0300	NUT,LOCK,12MM	1	1	1		
411	411AA1200	WASHER-PLAIN,12MM	1	1	1		
670	670B2012	O RING,12MM	1	1	1		
	(JKAER650CCDA13243 -)						

This catalog covers:

'09~'11 ER650 C9F/CAF/CBF Chassis

GRID NO.

E-8

This grid covers:

Footrests

F2160

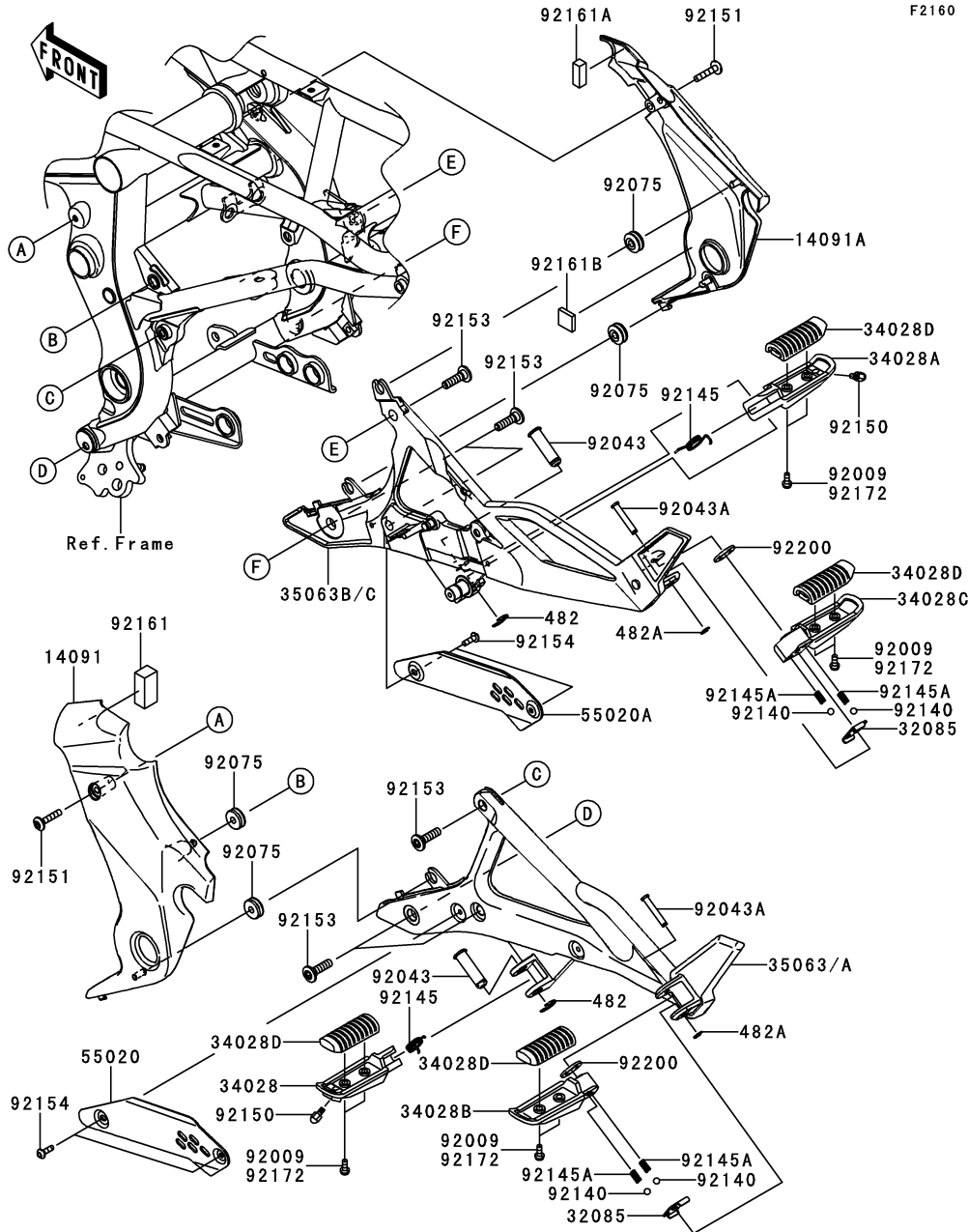

Ref. No.	Part No.	Description	Spec Code	Quantity-ER650			
				'09	'10	'11	
				C9F	CAF	CBF	
14091	14091-1584	COVER,PIVOT,LH	1	1	1		
14091A	14091-1585	COVER,PIVOT,RH	1	1	1		
32085	32085-0047	STOPPER,REAR STEP	2	2	2		
34028	34028-0127	STEP,FR,LH	1	1	1		
34028A	34028-0128	STEP,FR,RH	1	1	1		
34028B	34028-0129	STEP,RR,LH	1	1	1		
34028C	34028-0130	STEP,RR,RH	1	1	1		
34028D	34028-1430	STEP,RUBBER	4	4	4		
35063	35063-0522-18R	STAY,STEP,LH,F.S.BLACK	1	1			
35063A	35063-0522-45B	STAY,STEP,LH,P.SILVER	1		1		
35063B	35063-0523-18R	STAY,STEP,RH,F.S.BLACK	1	1			
35063C	35063-0523-45B	STAY,STEP,RH,P.SILVER	1		1		
55020	55020-0461	GUARD,STEP,LH	1	1	1		
55020A	55020-0462	GUARD,STEP,RH	1	1	1		
92009	92009-1404	SCREW,5X14	8	8			
92043	92043-0026	PIN,12X37.5	2	2	2		
92043A	92043-1595	PIN,6X40	2	2	2		
92075	92075-1067	DAMPER	4	4	4		
92140	92140-0008	BALL,6.35MM	4	4	4		
92145	92145-0723	SPRING,STEP RETURN	2	2	2		
92145A	92145-1319	SPRING	4	4	4		
92150	92150-1114	BOLT,BANK SENSOR	2	2	2		
92151	92151-1605	BOLT,SOCKET,6X30	2	2	2		
92153	92153-1630	BOLT,SOCKET,8X30	6	6	6		
92154	92154-0182	BOLT,SOCKET,5X16	4	4	4		
92161	92161-0670	DAMPER,19X15X40	1	1	1		
92161A	92161-0671	DAMPER,10X10X28	1	1	1		
92161B	92161-0731	DAMPER,UPP CNT COWLING	1	1	1		
92172	92172-0473	SCREW-PAN-WP-CROS,5X14			8		
92200	92200-0043	WASHER,16X26X2.3	2	2	2		
482	482EA0100	CIRCLIP-TYPE-E,10MM	2	2	2		
482A	482EA5000	CIRCLIP-TYPE-E	2	2	2		

This catalog covers:

'09~'11 ER650 C9F/CAF/CBF Chassis

GRID NO.

E-9

This grid covers:

Front Fender(s)

F2171

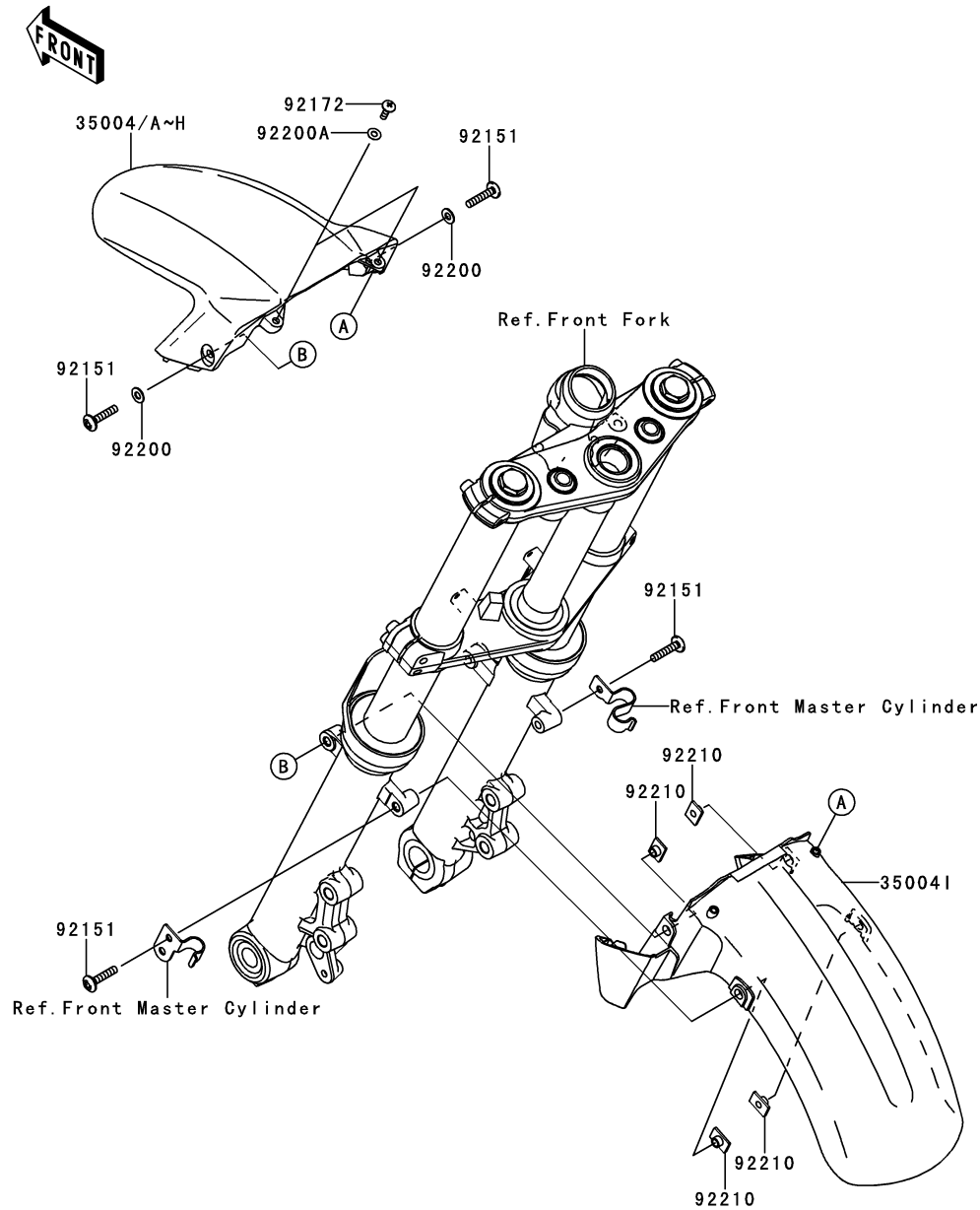

Ref. No.	Part No.	Description	Spec Code	Quantity-ER650			
				'09	'10	'11	
				C9F	CAF	CBF	
35004	35004-0110-G3	FENDER-FRONT,FR,P.WHITE			1		
35004A	35004-0110-H8	FENDER-FRONT,FR,EBONY		1			
35004B	35004-0110-15Q	FENDER-FRONT,FR,M.D.BLACK	1				
35004C	35004-0110-15S	FENDER-FRONT,FR,P.S.WHITE	1				
35004D	35004-0110-15T	FENDER-FRONT,FR,C.B.ORANGE	1				
35004E	35004-0110-15V	FENDER-FRONT,FR,M.F.S.BLACK		1			
35004F	35004-0110-15Z	FENDER-FRONT,FR,M.S.BLACK			1		
35004G	35004-0110-35A	FENDER-FRONT,FR,M.F.S.GREEN			1		
35004H	35004-0110-848	FENDER-FRONT,FR,P.B.ORANGE		1			
35004I	35004-0111	FENDER-FRONT,RR	1	1	1		
92151	92151-1605	BOLT,SOCKET,6X30	4	4	4		
92172	92172-0427	SCREW,TAPPING,5X16	2	2	2		
92200	92200-1388	WASHER,6.5X14X1	2	2	2		
92200A	92200-1480	WASHER,NYLON,5.3X11.5X0.5	2	2	2		
92210	92210-1352	NUT,PLATE,6MM	4	4	4		

This catalog covers:

'09~'11 ER650 C9F/CAF/CBF Chassis

GRID NO.

E-10

This grid covers:

Rear Fender(s)

F2172

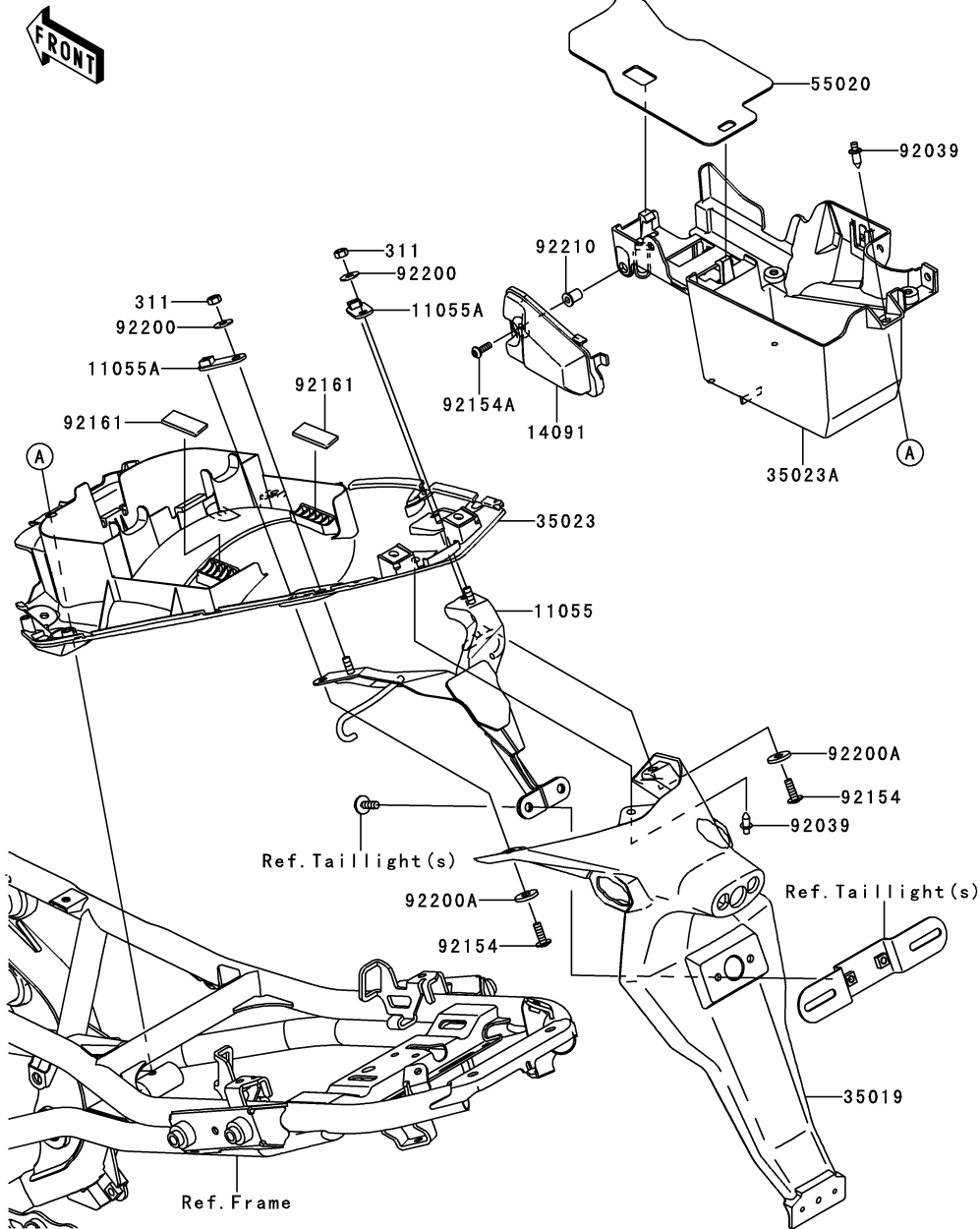

Ref. No.	Part No.	Description	Spec Code	Quantity-ER650		
				'09	'10	'11
				C9F	CAF	CBF
11055	11055-0587	BRACKET,FLAP	1	1	1	
11055A	11055-0843	BRACKET	2	2	2	
14091	14091-1678	COVER,SWITCH MAINTENANCE	1	1	1	
35019	35019-0075	FLAP	1	1	1	
35023	35023-0142	FENDER-REAR,RR	1	1	1	
35023A	35023-0163	FENDER-REAR,FR	1	1	1	
55020	55020-0220	GUARD,HEAT	1	1	1	
92039	92039-1283	RIVET	2	2	2	
92154	92154-0139	BOLT,SOCKET,6X18	2	2	2	
92154A	92154-0182	BOLT,SOCKET,5X16	1	1	1	
92161	92161-0773	DAMPER	2	2	2	
92200	92200-0430	WASHER,6.5X17X1	2	2	2	
92200A	92200-1388	WASHER,6.5X14X1	2	2	2	
92210	92210-0498	NUT,WELL,5MM	1	1	1	
311	311AA0600	NUT-HEX,6MM	2	2	2	

This catalog covers:

'09~'11 ER650 C9F/CAF/CBF Chassis

GRID NO.

E-11

This grid covers:

Stand(s)

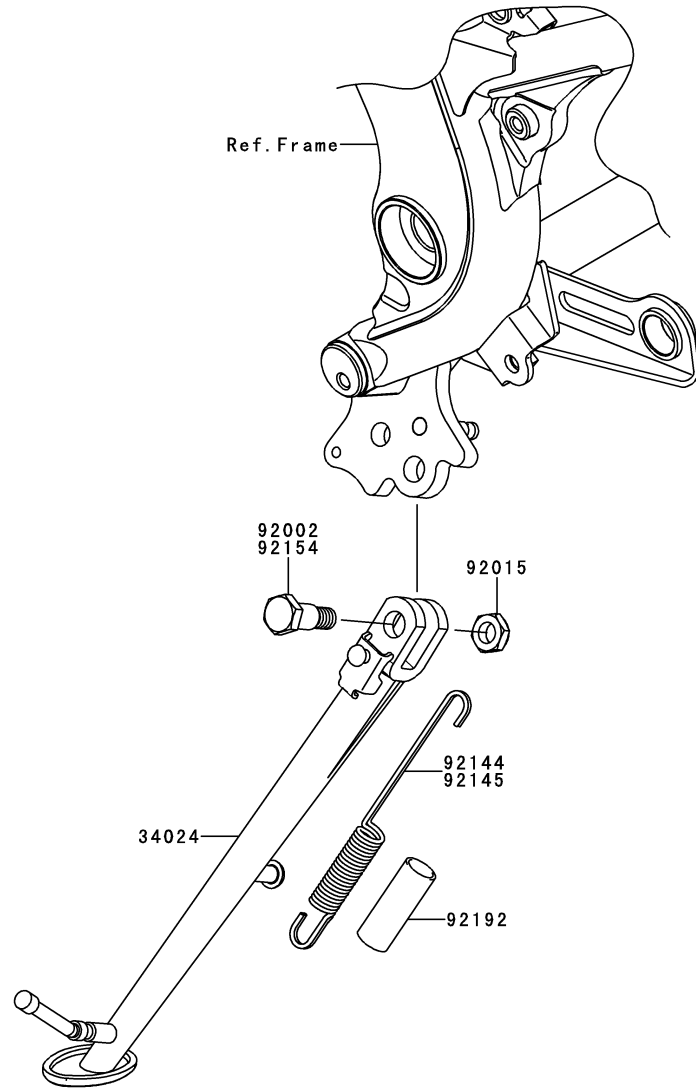

F2190

Ref. No.	Part No.	Description	Spec Code	Quantity-ER650			
				'09	'10	'11	
				C9F	CAF	CBF	
34024	34024-0096	STAND-SIDE	1	1	1		
92002	92002-1935	BOLT,SIDE STAND	1	1			
92015	92015-1188	NUT,LOCK,10MM,BLACK	1	1	1		
92144	92144-1818	SPRING,SIDE STAND	1	1			
92145	92145-0813	SPRING,SIDE STAND			1		
92154	92154-0437	BOLT,10X32.5			1		
92192	92192-0700	TUBE,14X17X50	1	1	1		

This catalog covers:

'09~'11 ER650 C9F/CAF/CBF Chassis

GRID NO.

E-12

This grid covers:

Tires

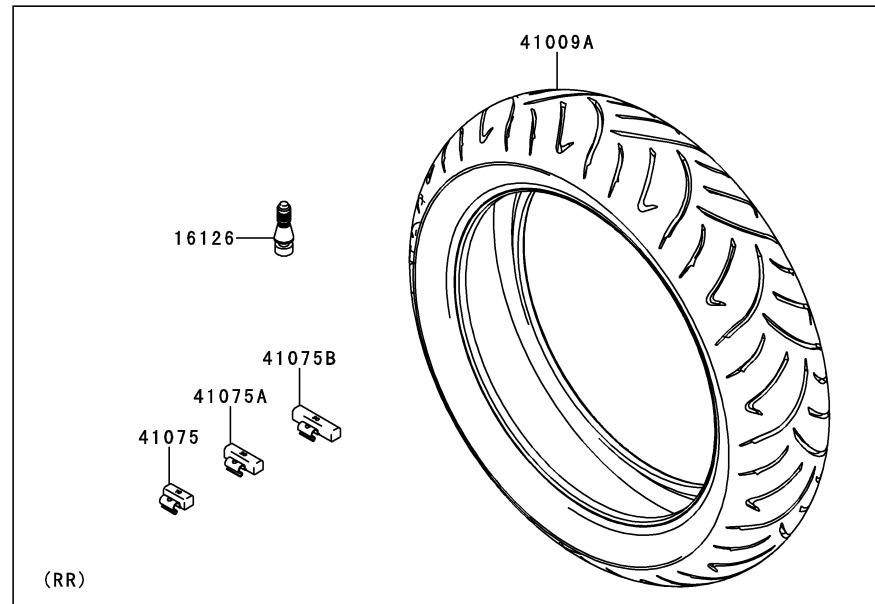
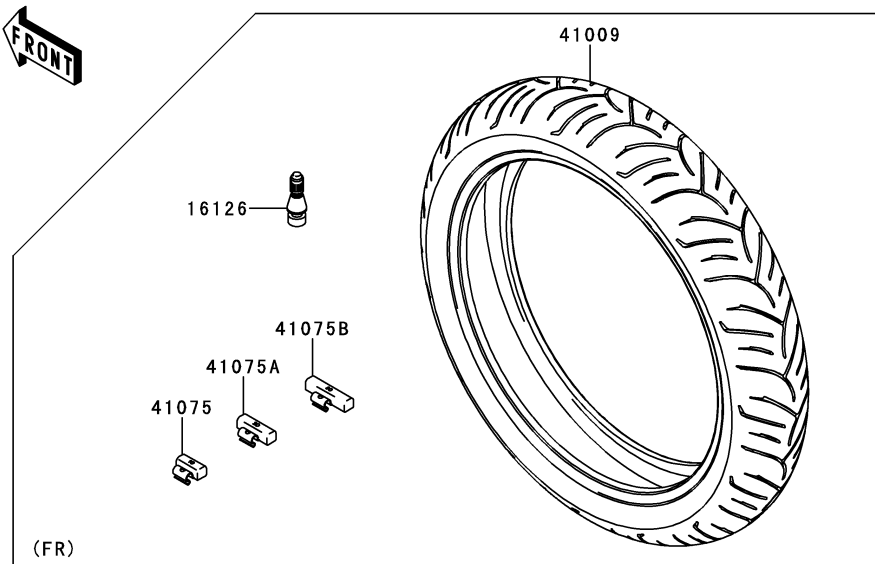

F2210

Ref. No.	Part No.	Description	Spec Code	Quantity-ER650			
				'09	'10	'11	
				C9F	CAF	CBF	
16126	16126-1140	VALVE,TIRE	2	2	2		
41009	41009-0190	TIRE,FR,120/70ZR17(58W),R.S. G	1	1	1		
41009A	41009-0191	TIRE,RR,160/60ZR17(69W),R.S. G	1	1	1		
41075	41075-0007	BALANCER-WHEEL,10G,SILVER	AR	AR	AR		
41075A	41075-0008	BALANCER-WHEEL,20G,SILVER	AR	AR	AR		
41075B	41075-0009	BALANCER-WHEEL,30G,SILVER	AR	AR	AR		

This catalog covers:

'09~'11 ER650 C9F/CAF/CBF Chassis

GRID NO.

E-13

This grid covers:

Front Hub

F2230

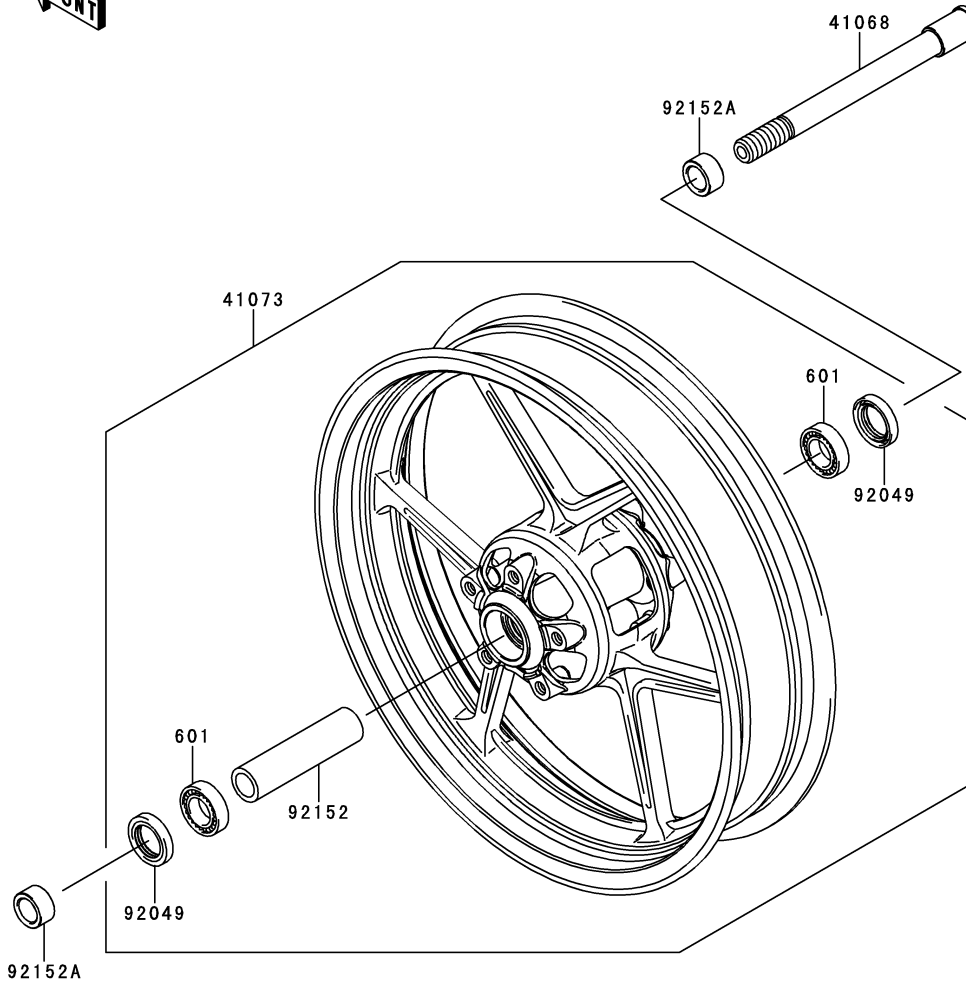

Ref. No.	Part No.	Description	Spec Code	Quantity-ER650			
				'09	'10	'11	
				C9F	CAF	CBF	
41068	41068-0059	AXLE,FR	1	1	1		
41073	41073-0154-QT	WHEEL-ASSY,FR,G.BLACK	1	1	1		
92049	92049-0130	SEAL-OIL,BJN30427	2	2	2		
92152	92152-0087	COLLAR,FR HUB,L=115	1	1	1		
92152A	92152-0946	COLLAR,20X30X15.5	2	2	2		
601	601B6004UU	BEARING-BALL,#6004UUC3	2	2	2		

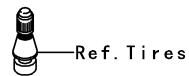

This catalog covers:

'09~'11 ER650 C9F/CAF/CBF Chassis

GRID NO.

E-14

This grid covers:

Rear Hub

F2240

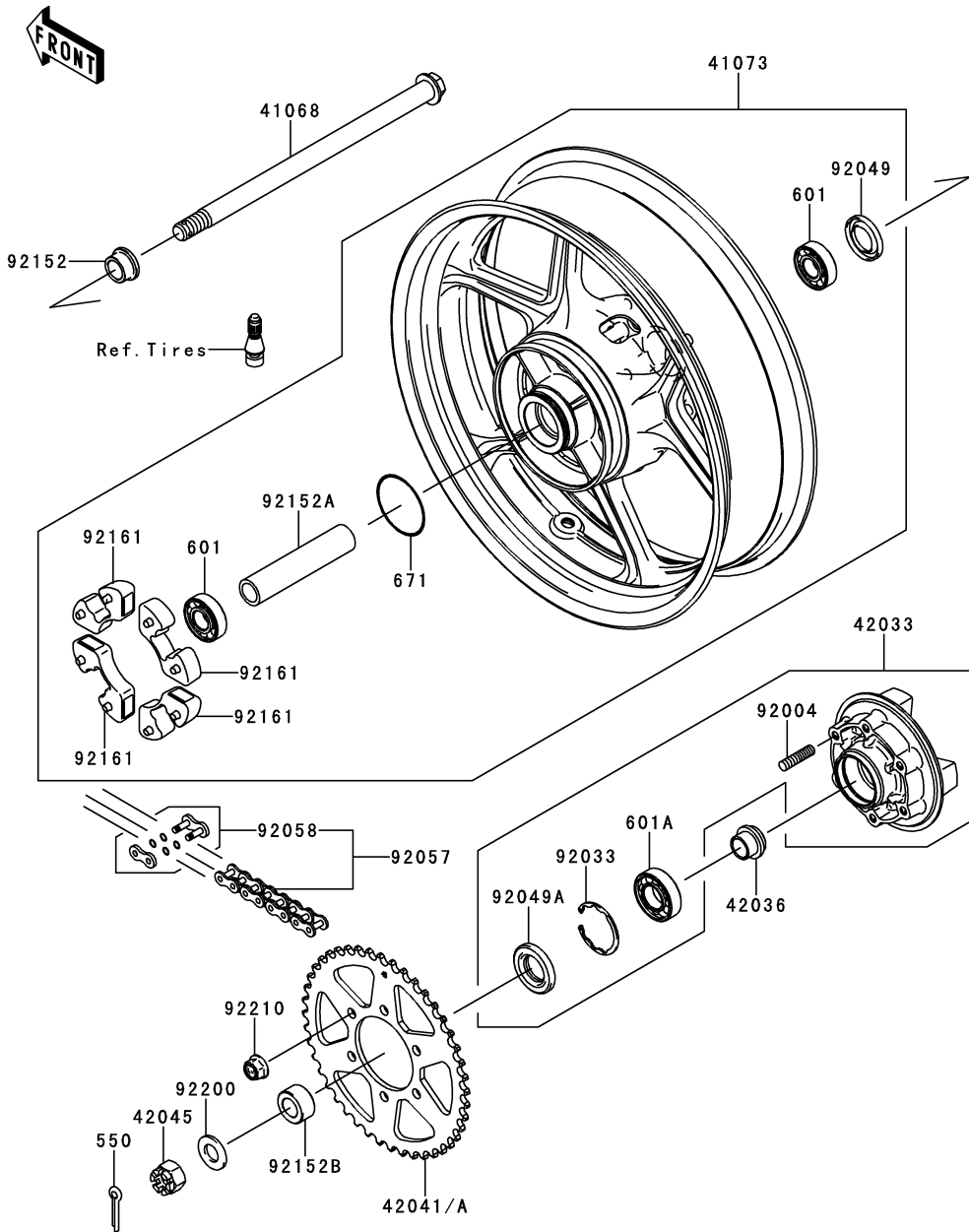

Ref. No.	Part No.	Description	Spec Code	Quantity-ER650			
				'09	'10	'11	
				C9F	CAF	CBF	
41068	41068-0071	AXLE	1	1	1		
41073	41073-0146-QT	WHEEL-ASSY,RR,G.BLACK	1	1	1		
42033	42033-0028	COUPLING-ASSY,RR HUB	1	1	1		
42036	42036-1251	SLEEVE,RR HUB,L=23	1	1	1		
42041	42041-0061	SPROCKET-HUB,45T	1				
42041A	42041-0087	SPROCKET-HUB,46T		1	1		
42045	42045-018	NUT,CASTLE,18MM	1	1	1		
92004	92004-0028	STUD,10X19	6	6	6		
92033	92033-1043	RING-SNAP,52MM	1	1	1		
92049	92049-0140	SEAL-OIL,28 47 5	1	1	1		
92049A	92049-1287	SEAL-OIL	1	1	1		
92057	92057-0163	CHAIN,DRIVE,DID520VP2X114L	1	1	1		
92058	92058-0018	JOINT-CHAIN,DRIVE	1	1	1		
92152	92152-0302	COLLAR,RR AXLE,RH,L=17	1	1	1		
92152A	92152-0748	COLLAR,20.2X28X133	1	1	1		
92152B	92152-0751	COLLAR,20X35X18	1	1	1		
92161	92161-0303	DAMPER,SHOCK,RR HUB	4	4	4		
92200	92200-0296	WASHER,19X36X3.2	1	1	1		
92210	92210-0276	NUT,LOCK,FLANGED,10MM	6	6	6		
550	550AA4035	PIN-COTTER,4.0X35	1	1	1		
601	601B6204UU	BEARING-BALL,6204UUC3	2	2	2		
601A	601B6205UU	BEARING-BALL	1	1	1		
671	671B2560	O RING,60MM	1	1	1		

This catalog covers:

'09~'11 ER650 C9F/CAF/CBF Chassis

GRID NO.

F-3

This grid covers:

Brake Pedal

F2260

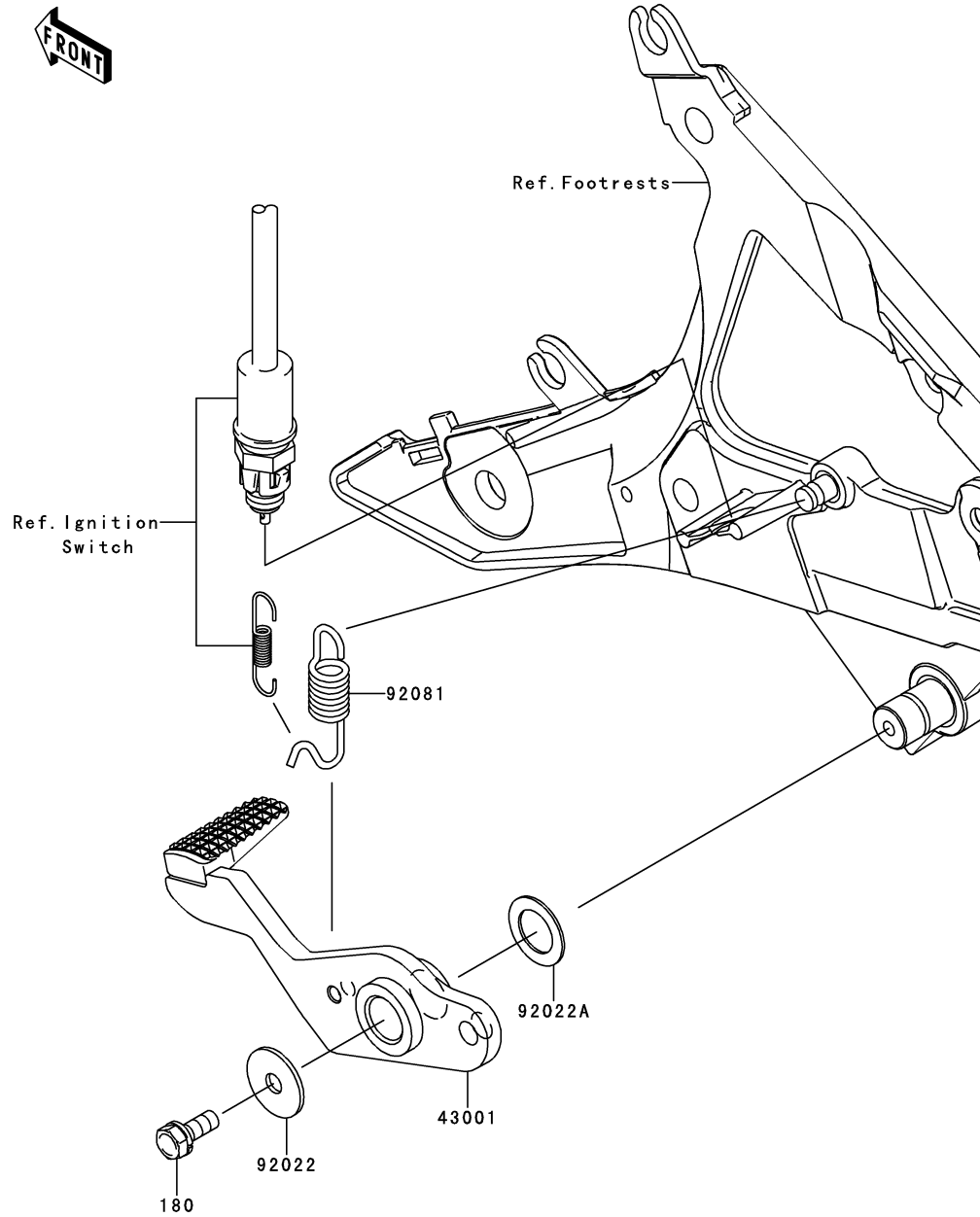

Ref. No.	Part No.	Description	Spec Code	Quantity-ER650			
				'09	'10	'11	
43001	43001-0104	LEVER-BRAKE,PEDAL		1	1	1	
92022	92022-228	WASHER,7X24X1.6		1	1	1	
92022A	92022-326	WASHER,15.3X24X1		1	1	1	
92081	92081-1833	SPRING,BRAKE PEDAL		1	1	1	
180	180AA0616	BOLT-UPSET-WS,6X16		1	1	1	

F2291

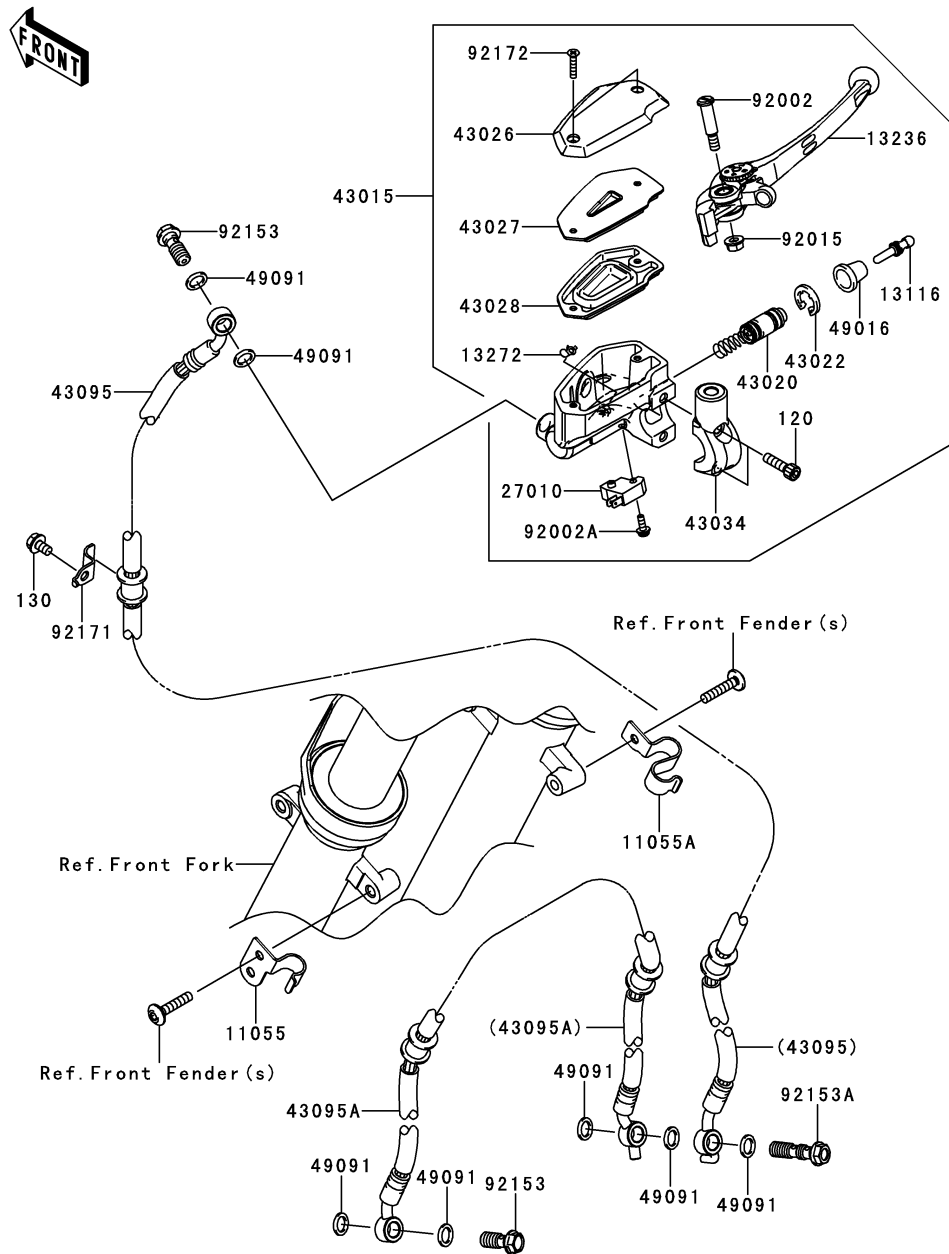

Ref. No.	Part No.	Description	Spec Code	Quantity-ER650			
				'09	'10	'11	
				C9F	CAF	CBF	
11055	11055-1115	BRACKET	1	1	1		
11055A	11055-1116	BRACKET	1	1	1		
13116	13116-0032	ROD-PUSH	1	1	1		
13236	13236-0169	LEVER-COMP,FRONT BRAKE	1	1	1		
13272	13272-0573	PLATE	1	1	1		
27010	27010-0025	SWITCH,BRAKE	1	1	1		
43015	43015-0116	CYLINDER-ASSY-MASTER,FR	1	1	1		
43020	43020-0015	PISTON-COMP-BRAKE	1	1	1		
43022	43022-1010	STOPPER-BRAKE,PISTON	1	1	1		
43026	43026-0019	CAP-BRAKE	1	1	1		
43027	43027-0008	PLATE-DIAPHRAGM	1	1	1		
43028	43028-0015	DIAPHRAGM	1	1	1		
43034	43034-0049	HOLDER-BRAKE,MASTER CYLINDER	1	1	1		
43095	43095-0411	HOSE-BRAKE,FR,L=755	1	1	1		
43095A	43095-0412	HOSE-BRAKE,FR,L=545	1	1	1		
49016	49016-1044	COVER-SEAL,MASTER CYLINDER	1	1	1		
49091	49091-0001	WASHER-SEAL,10.1X14.5X1.5	7	7	7		
92002	92002-1322	BOLT,LEVER SET,BLACK	1	1	1		
92002A	92002-1323	BOLT,SCREW,4X12	1	1	1		
92015	92015-1528	NUT,FLANGED,6MM	1	1	1		
92153	92153-0627	BOLT,OIL,L=23	2	2	2		
92153A	92153-0628	BOLT,OIL,L=37	1	1	1		
92171	92171-1887	CLAMP	1	1	1		
92172	92172-0320	SCREW,4X20	2	2	2		
120	120CB0622	BOLT-SOCKET,6X22	2	2	2		
130	130BB0610	BOLT-FLANGED,6X10	1	1	1		

This catalog covers:

'09~'11 ER650 C9F/CAF/CBF Chassis

GRID NO.

F-5

This grid covers:

Front Brake

F2292

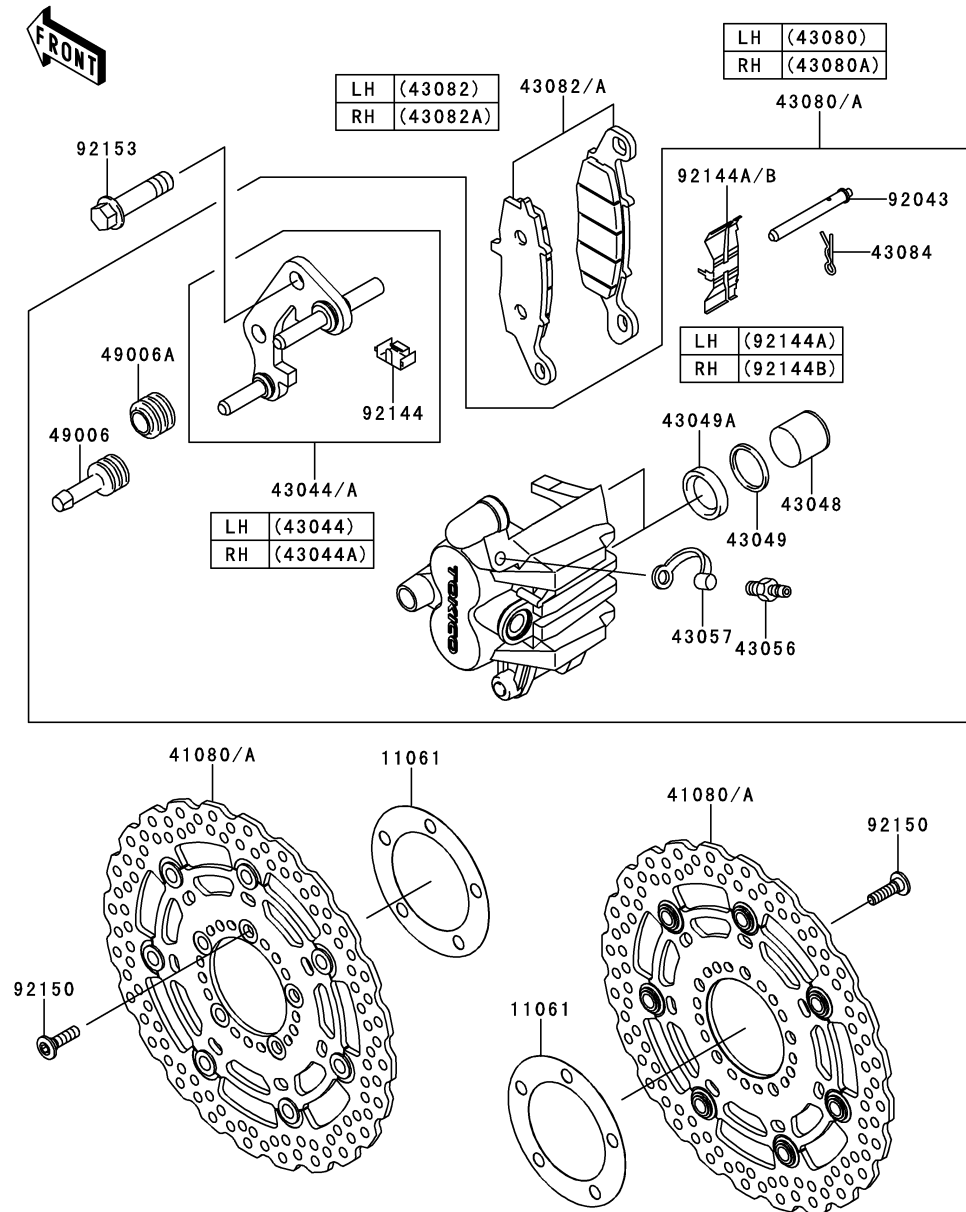

Ref. No.	Part No.	Description	Spec Code	Quantity-ER650		
				'09	'10	'11
				C9F	CAF	CBF
11061	11061-0029	GASKET,DISC PLATE	2	2	2	
41080	41080-0161-111	DISC,FR,HOUSING BLK+DISC SIL	2	2		
41080A	41080-0161-32L	DISC,FR,HOUSING BLK+DISC BLK			2	
43044	43044-1115	HOLDER-COMP-CALIPER,FR,LH	1	1	1	
43044A	43044-1116	HOLDER-COMP-CALIPER,FR,RH	1	1	1	
43048	43048-1052	PISTON-CALIPER	4	4	4	
43049	43049-1055	PACKING,PISTON	4	4	4	
43049A	43049-1096	PACKING,PISTON SEAL	4	4	4	
43056	43056-1054	BREATHER-BRAKE	2	2	2	
43057	43057-003	CAP-BREATHER	2	2	2	
43080	43080-0076-DJ	CALIPER-SUB-ASSY,FR,LH,BLACK	1	1	1	
43080A	43080-0077-DJ	CALIPER-SUB-ASSY,FR,RH,BLACK	1	1	1	
43082	43082-0050	PAD-ASSY-BRAKE,LH	1	1	1	
43082A	43082-0051	PAD-ASSY-BRAKE,RH	1	1	1	
43084	43084-003	CLAMP,PAD	2	2	2	
49006	49006-1054	BOOT,CALIPER	2	2	2	
49006A	49006-1095	BOOT,CALIPER	2	2	2	
92043	92043-1489	PIN,PAD	2	2	2	
92144	92144-1831	SPRING,STOPPER	2	2	2	
92144A	92144-1832	SPRING,PAD,LH	1	1	1	
92144B	92144-1844	SPRING,PAD,RH	1	1	1	
92150	92150-1771	BOLT,SOCKET,8X30	10	10	10	
92153	92153-0587	BOLT,FLANGED,10X41	4	4	4	

This catalog covers:

'09~'11 ER650 C9F/CAF/CBF Chassis

GRID NO.

F-6

This grid covers:

Rear Master Cylinder

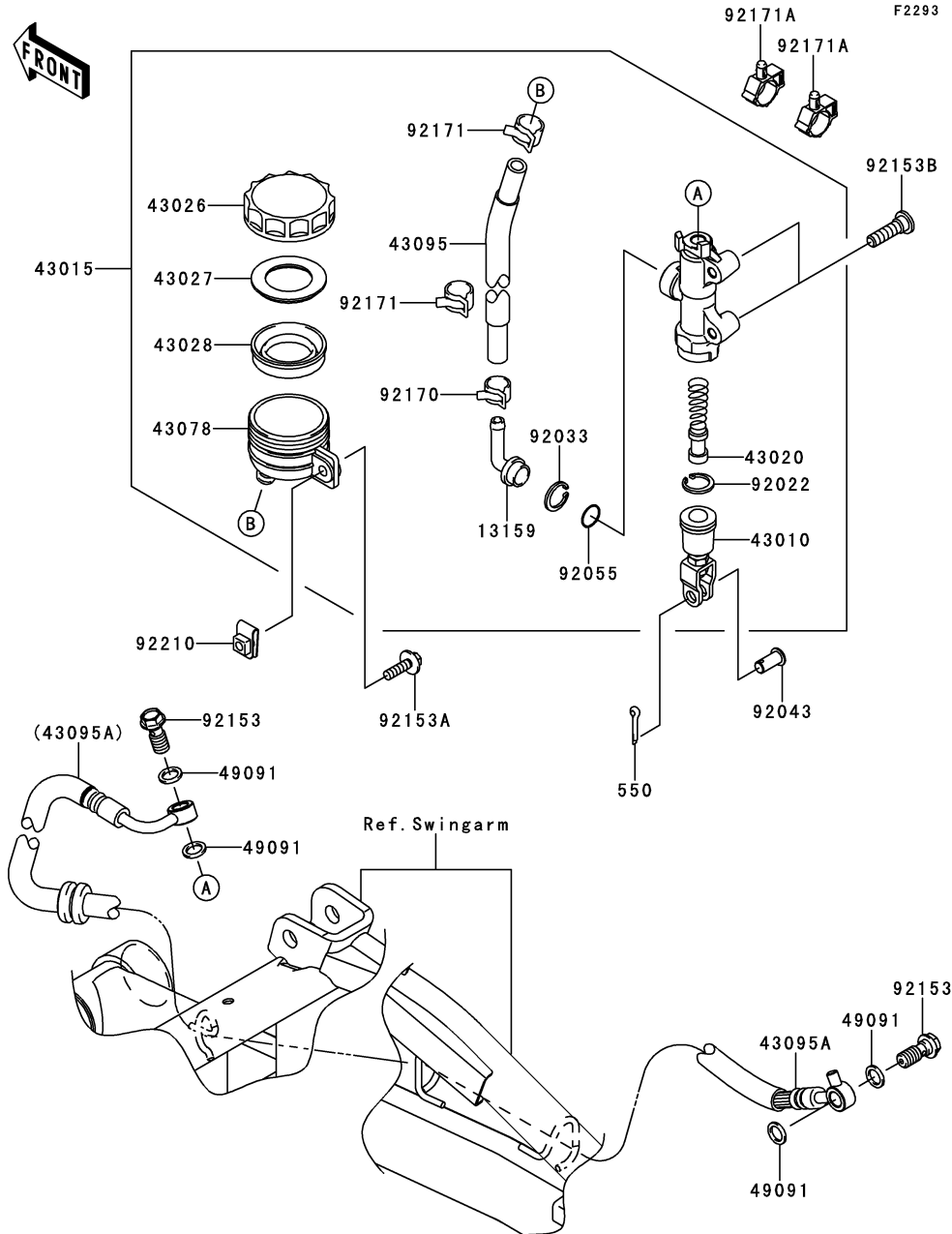

Ref. No.	Part No.	Description	Spec Code	Quantity-ER650		
				'09	'10	'11
				C9F	CAF	CBF
13159	13159-1056	CONNECTOR	1	1	1	
43010	43010-1062	ROD-ASSY-BRAKE	1	1	1	
43015	43015-0122	CYLINDER-ASSY-MASTER,RR	1	1	1	
43020	43020-1094	PISTON-COMP-BRAKE	1	1	1	
43026	43026-1051	CAP-BRAKE	1	1	1	
43027	43027-1051	PLATE-DIAPHRAGM	1	1	1	
43028	43028-1057	DIAPHRAGM,MASTER CYLINDER	1	1	1	
43078	43078-1082	RESERVOIR,RR MASTER CYLINDER	1	1	1	
43095	43095-0193	HOSE-BRAKE,RR MASTER CYLINDER	1	1	1	
43095A	43095-0413	HOSE-BRAKE,RR,L=712	1	1	1	
49091	49091-0001	WASHER-SEAL,10.1X14.5X1.5	4	4	4	
92022	92022-1601	WASHER,CIRCRIP	1	1	1	
92033	92033-1186	RING-SNAP,20.5MM	1	1	1	
92043	92043-0182	PIN	1	1	1	
92055	92055-1251	RING-O,MASTER CYLINDER	1	1	1	
92153	92153-0627	BOLT,OIL,L=23	2	2	2	
92153A	92153-0725	BOLT,6X22	1	1	1	
92153B	92153-1624	BOLT,SOCKET,8X30	2	2	2	
92170	92170-1091	CLAMP,HOSE	1	1	1	
92171	92171-0463	CLAMP,HOSE	2	2	2	
92171A	92171-0955	CLAMP	2	2	2	
92210	92210-0474	NUT,6MM	1	1	1	
550	550AA2015	PIN-COTTER,2.0X15	1	1	1	

This catalog covers:

'09~'11 ER650 C9F/CAF/CBF Chassis

GRID NO.

F-7

This grid covers:

Rear Brake

F2294

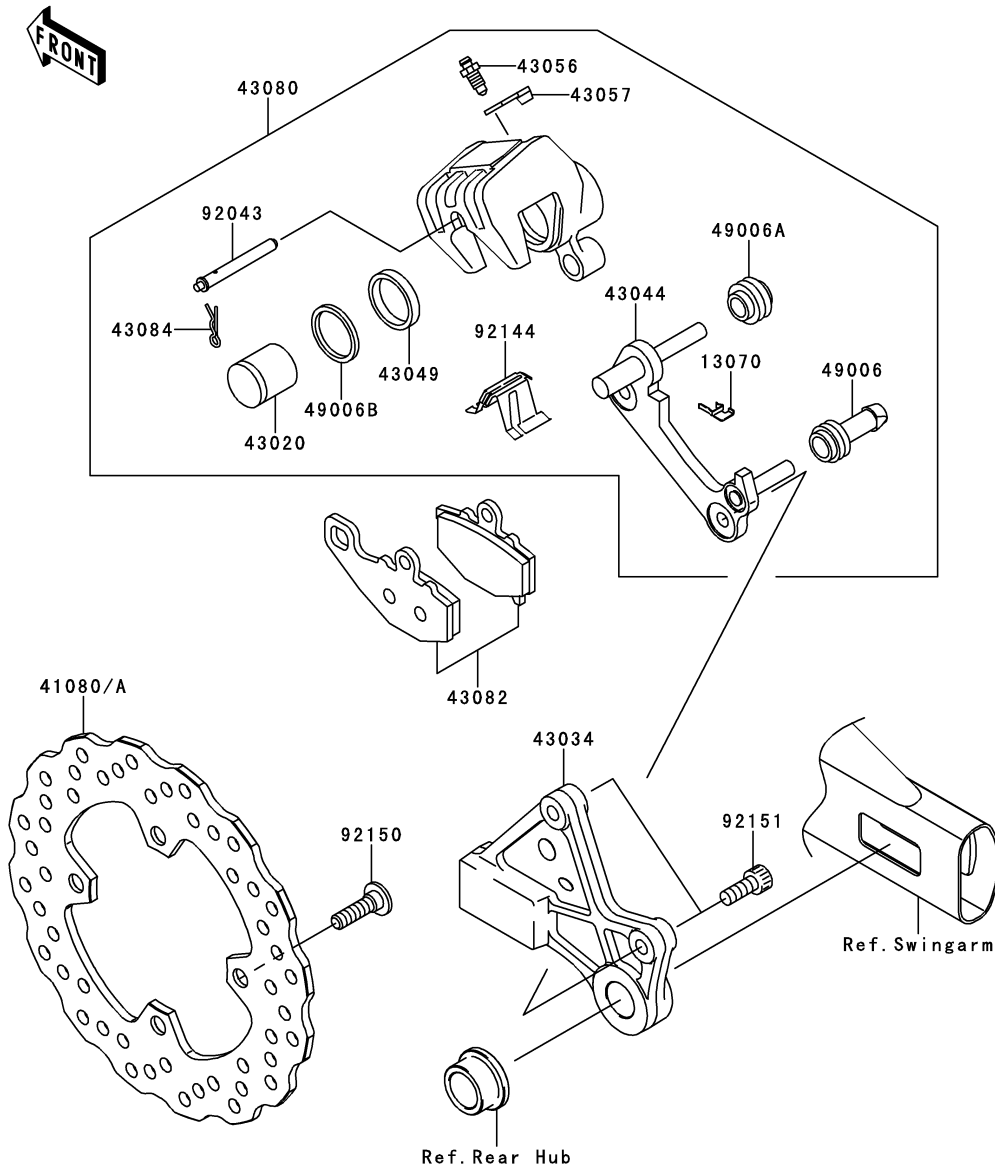

Ref. No.	Part No.	Description	Spec Code	Quantity-ER650		
				'09	'10	'11
				C9F	CAF	CBF
13070	13070-0045	GUIDE,BRAKE PAD	1	1	1	
41080	41080-0162	DISC,RR	1	1		
41080A	41080-0200	DISC,RR			1	
43020	43020-1119	PISTON-COMP-BRAKE	1	1	1	
43034	43034-0037	HOLDER-BRAKE,REAR CALIPER	1	1	1	
43044	43044-1110	HOLDER-COMP-CALIPER,RR	1	1	1	
43049	43049-1097	PACKING,PISTON SEAL	1	1	1	
43056	43056-1054	BREATHER-BRAKE	1	1	1	
43057	43057-003	CAP-BREATHER	1	1	1	
43080	43080-0085-DJ	CALIPER-SUB-ASSY,RR,BLACK	1	1	1	
43082	43082-1213	PAD-ASSY-BRAKE	1	1	1	
43084	43084-003	CLAMP,PAD	1	1	1	
49006	49006-1054	BOOT,CALIPER	1	1	1	
49006A	49006-1095	BOOT,CALIPER	1	1	1	
49006B	49006-1212	BOOT,PISTON SEAL	1	1	1	
92043	92043-1489	PIN,PAD	1	1	1	
92144	92144-1719	SPRING,PAD	1	1	1	
92150	92150-1771	BOLT,SOCKET,8X30	4	4	4	
92151	92151-1289	BOLT,SOCKET,8X20	2	2	2	

This catalog covers:

'09~'11 ER650 C9F/CAF/CBF Chassis

GRID NO.

F-8

This grid covers:

Handlebar

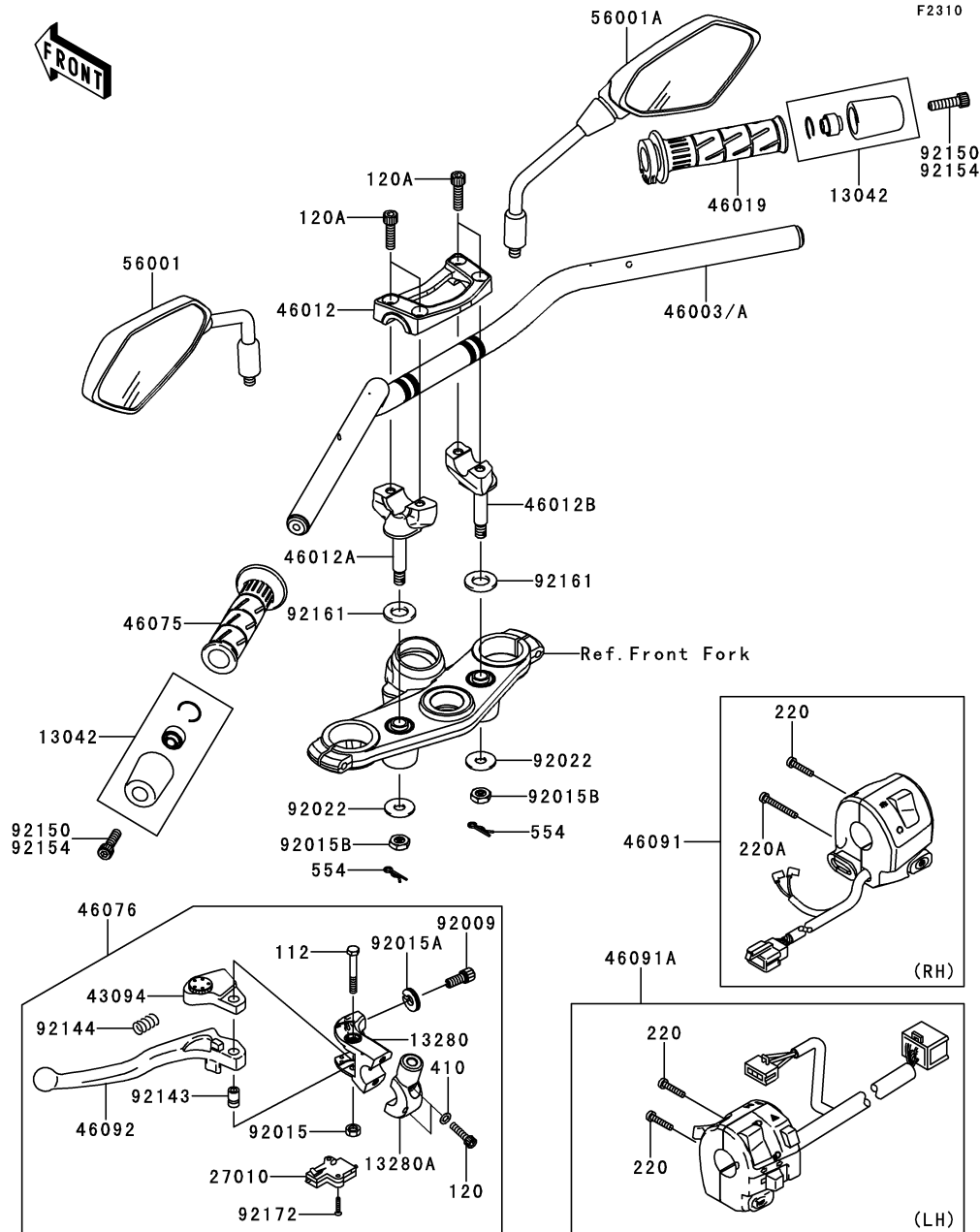

Ref. No.	Part No.	Description	Spec Code	Quantity-ER650			
				'09	'10	'11	
				C9F	CAF	CBF	
13042	13042-5002	WEIGHT,HANDLE	2	2	2		
13280	13280-0306	HOLDER,CLUTCH LEVER	1	1	1		
13280A	13280-0307	HOLDER,CLUTCH LEVER	1	1	1		
27010	27010-1094	SWITCH,CLUTCH,BLACK	1	1	1		
43094	43094-1053	ADJUSTER,CLUTCH LEVER	1	1	1		
46003	46003-0152-10	HANDLE,BLACK		1	1		
46003A	46003-0152-26M	HANDLE,F.M.GRAY	1				
46012	46012-0059	HOLDER-HANDLE,UPP	1	1	1		
46012A	46012-0060	HOLDER-HANDLE,LWR,LH	1	1	1		
46012B	46012-0061	HOLDER-HANDLE,LWR,RH	1	1	1		
46019	46019-0001	GRIP-ASSY,THROTTLE	1	1	1		
46075	46075-1144	GRIP,LH	1	1	1		
46076	46076-0052	LEVER-ASSY-GRIP,CLUTCH	1	1	1		
46091	46091-0159	HOUSING-ASSY-CONTROL,RH	1	1	1		
46091A	46091-0160	HOUSING-ASSY-CONTROL,LH	1	1	1		
46092	46092-0031	LEVER-GRIP,CLUTCH	1	1	1		
56001	56001-0125	MIRROR-ASSY,LH	1	1	1		
56001A	56001-0126	MIRROR-ASSY,RH	1	1	1		
92009	92009-1134	SCREW,CABLE ADJUST,8MM,BLACK	1	1	1		
92015	92015-1191	NUT,LOCK,6MM,BLACK	1	1	1		
92015A	92015-1197	NUT,CABLE ADJUST LOCK,8MM,BLK	1	1	1		
92015B	92015-1962	NUT,LOCK,10MM	2	2	2		
92022	92022-1088	WASHER,10.2X28X2	2	2	2		
92143	92143-1379	COLLAR	1	1	1		
92144	92144-1467	SPRING	1	1	1		
92150	92150-1604	BOLT,SOCKET,8X30	2	2			
92154	92154-0440	BOLT,SOCKET,8X30			2		
92161	92161-0037	DAMPER	2	2	2		
92172	92172-0183	SCREW,3X16	2	2	2		
112	112AB0645	BOLT-UPSET,6X45	1	1	1		
120	120CB0625	BOLT-SOCKET,6X25	2	2	2		
120A	120CC0830	BOLT-SOCKET,8X30	4	4	4		
220	220AB0525	SCREW-PAN-CROSS,5X25	3	3	3		
220A	220AB0540	SCREW-PAN-CROSS,5X40	1	1	1		
410	410AB0600	WASHER-PLAIN-SMALL,6MM	2	2	2		
554	554DB0800	PIN-SNAP	2	2	2		

This catalog covers:

'09~'11 ER650 C9F/CAF/CBF Chassis

GRID NO.

F-9

This grid covers:

Front Fork

F2340

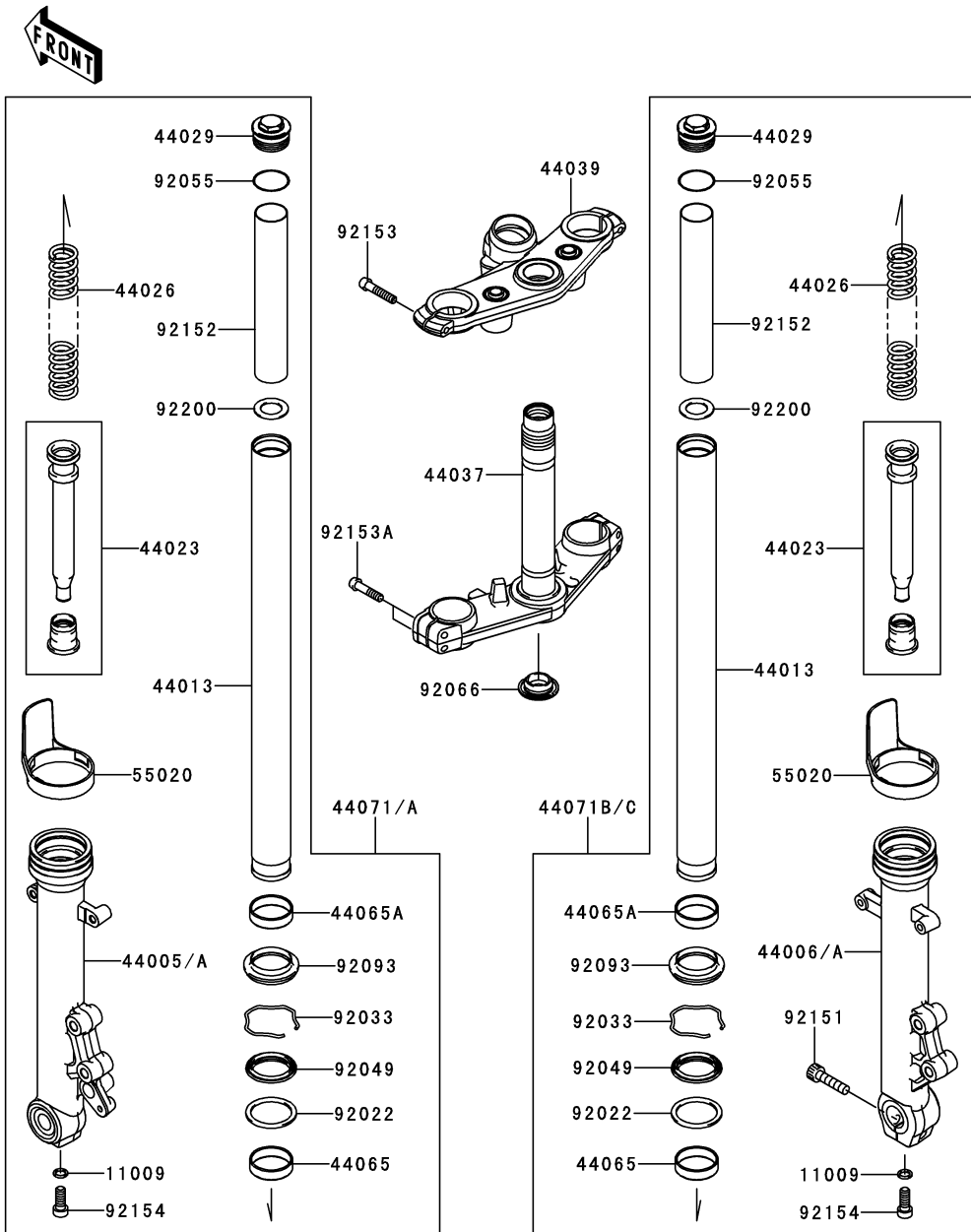

Ref. No.	Part No.	Description	Spec Code	Quantity-ER650			
				'09	'10	'11	
				C9F	CAF	CBF	
11009	11009-1325	GASKET,PIPE-COMP-SUSP	2	2	2		
44005	44005-0066-26M	PIPE-LEFT FORK OUTER,F.M.GRAY	1				
44005A	44005-0066-32A	PIPE-LEFT FORK OUTER,S.BLACK		1	1		
44006	44006-0062-26M	PIPE-RIGHT FORK OUTER,F.M.GRAY	1				
44006A	44006-0062-32A	PIPE-RIGHT FORK OUTER,S.BLACK		1	1		
44013	44013-0055	PIPE-FORK INNER	2	2	2		
44023	44023-0072	CYLINDER-SET-FORK	2	2	2		
44026	44026-0133	SPRING-FRONT FORK	2	2	2		
44029	44029-0005	SEAT-FORK SPRING	2	2	2		
44037	44037-0106	HOLDER-FORK UNDER	1	1	1		
44039	44039-0089	HOLDER-FORK UPPER	1	1	1		
44065	44065-0014	BUSHING-FRONT FORK,INNER TUBE	2	2	2		
44065A	44065-1115	BUSHING-FRONT FORK,OUTER TUBE	2	2	2		
44071	44071-0543-26M	DAMPER-ASSY,FORK,LH,F.M.GRAY	1				
44071A	44071-0543-32A	DAMPER-ASSY,FORK,LH,S.BLACK		1	1		
44071B	44071-0544-26M	DAMPER-ASSY,FORK,RH,F.M.GRAY	1				
44071C	44071-0544-32A	DAMPER-ASSY,FORK,RH,S.BLACK		1	1		
55020	55020-1691	GUARD,FORK	2	2	2		
92022	92022-1298	WASHER,FORK OUTER TUBE	2	2	2		
92033	92033-1036	RING-SNAP	2	2	2		
92049	92049-0073	SEAL-OIL	2	2	2		
92055	92055-1321	RING-O	2	2	2		
92066	92066-0032	PLUG	1	1	1		
92093	92093-1472	SEAL,FORK OUTER TUBE	2	2	2		
92151	92151-1357	BOLT,SOCKET,10X40	1	1	1		
92152	92152-0767	COLLAR,FORK	2	2	2		
92153	92153-0506	BOLT,SOCKET,8X40	2	2	2		
92153A	92153-1472	BOLT,SOCKET,8X35	4	4	4		
92154	92154-0296	BOLT,SOCKET,FORK CYLINDER	2	2	2		
92200	92200-1302	WASHER	2	2	2		

This catalog covers:

'09~'11 ER650 C9F/CAF/CBF Chassis

GRID NO.

F-10

This grid covers:

Fuel Tank

F2410

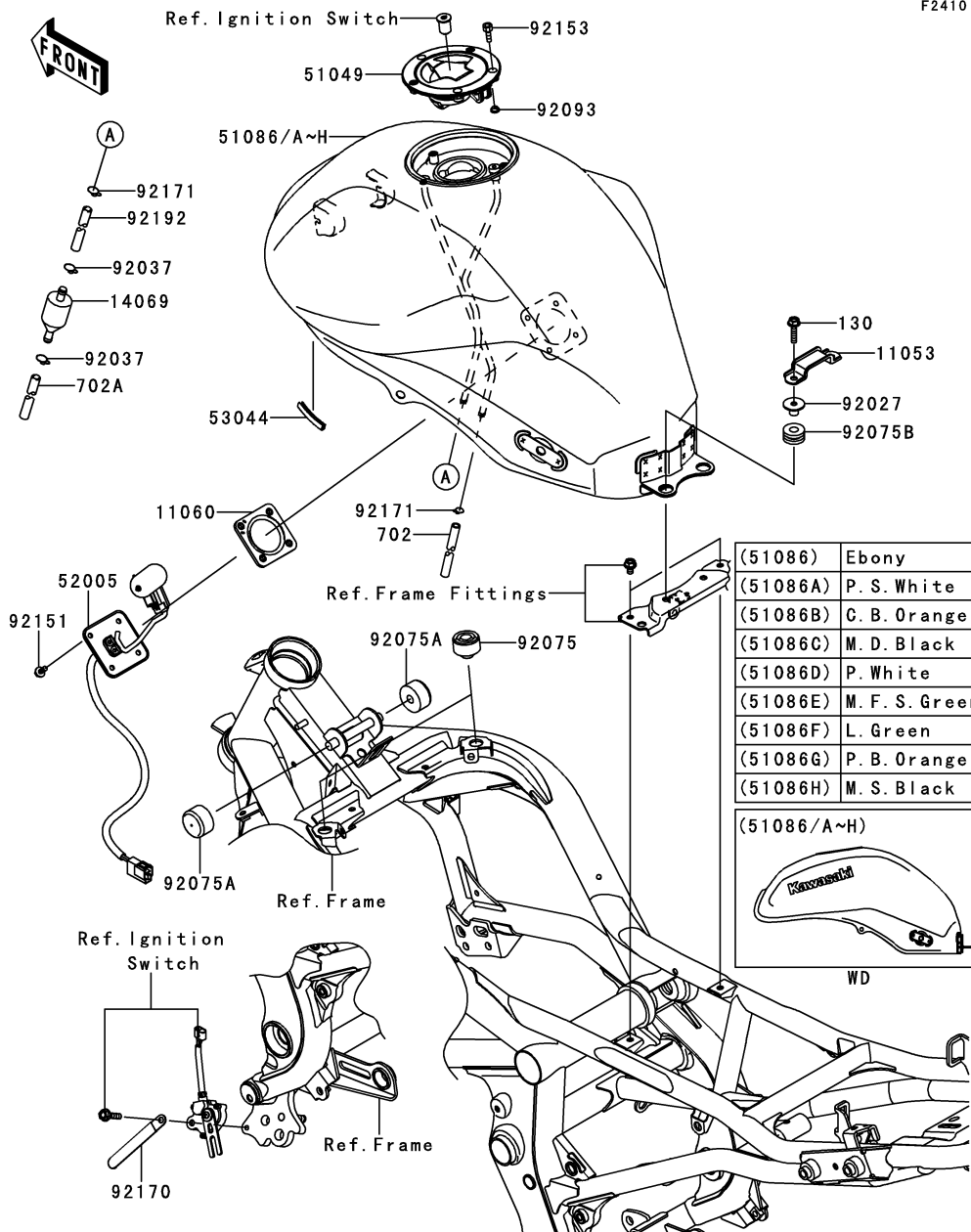

Ref. No.	Part No.	Description	Spec Code	Quantity-ER650				
				'09	'10	'11		
				C9F	CAF	CBF		
11053	11053-1812	BRACKET,SEAT	1	1	1			
11060	11060-1952	GASKET,FUEL GAUGE	1	1	1			
14069	14069-1004	BREATHER,FUEL TANK	1	1	1			
51049	51049-0039	CAP-TANK,FUEL	1	1	1			
51086	51086-5160-H8	TANK-COMP-FUEL,EBONY			1			
51086A	51086-5168-15S	TANK-COMP-FUEL,P.S.WHITE	1					
51086B	51086-5168-15T	TANK-COMP-FUEL,C.B.ORANGE	1					
51086C	51086-5273-15Q	TANK-COMP-FUEL,M.D.BLACK	1					
51086D	51086-5375-G3	TANK-COMP-FUEL,P.WHITE					1	
51086E	51086-5375-35A	TANK-COMP-FUEL,M.F.S.GREEN					1	
51086F	51086-5375-777	TANK-COMP-FUEL,L.GREEN					1	
51086G	51086-5375-848	TANK-COMP-FUEL,P.B.ORANGE					1	
51086H	51086-5378-15Z	TANK-COMP-FUEL,M.S.BLACK					1	
52005	52005-0076	GAUGE,FUEL	1	1	1			
53044	53044-1249	TRIM,L=60	2	2	2			
92027	92027-251	COLLAR,L=13.1	2	2	2			
92037	92037-147	CLAMP,TUBE	2	2	2			
92075	92075-015	DAMPER	2	2	2			
92075A	92075-125	DAMPER,FUEL TANK	2	2	2			
92075B	92075-1690	DAMPER	2	2	2			
92093	92093-1030	SEAL,FUEL TANK CAP	1	1	1			
92151	92151-1599	BOLT,5X12	4	4	4			
92153	92153-1616	BOLT,SOCKET,5X16	3	3	3			
92170	92170-1925	CLAMP	1	1	1			
92171	92171-1973	CLAMP,8X0.7	2	2	2			
92192	92192-0733	TUBE,6X9X500	1	1	1			
130	130BB0625	BOLT-FLANGED,6X25	2	2	2			
702	702A06690	TUBE-RUBBER,6X9X690	1	1	1			
702A	702A07100	TUBE-RUBBER,7X10X100	1	1	1			

This catalog covers:

'09~'11 ER650 C9F/CAF/CBF Chassis

GRID NO.

F-11

This grid covers:

Seat

F2510



Ref. No.	Part No.	Description	Spec Code	Quantity-ER650		
				'09	'10	'11
				C9F	CAF	CBF
53003	53003-0128-MA	LEATHER,SEAT,BLACK		1	1	1
53066	53066-0205-MA	SEAT-ASSY,DUAL,BLACK		1	1	1
92161	92161-1321	DAMPER,SEAT		1	1	1

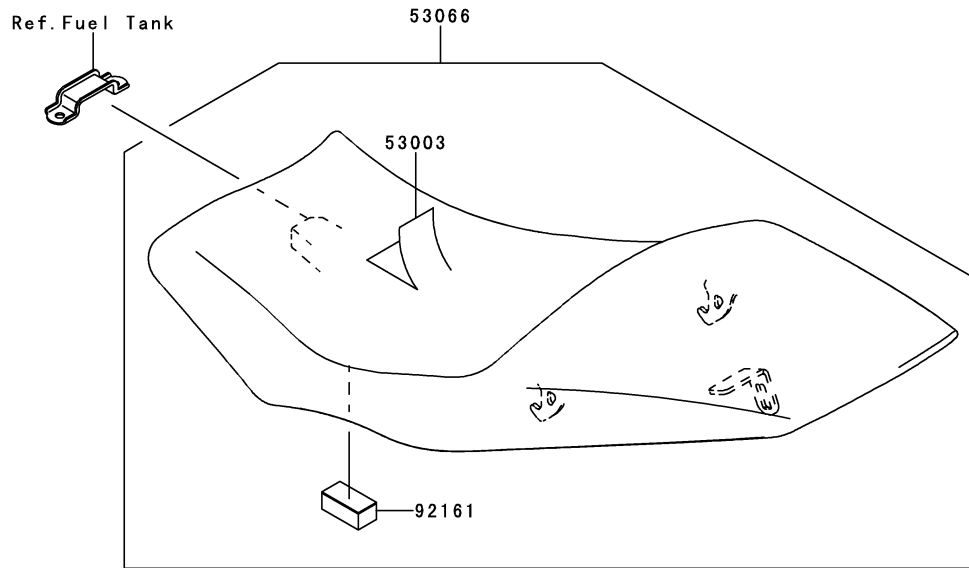

This catalog covers:

'09~'11 ER650 C9F/CAF/CBF Chassis

GRID NO.

F-12

This grid covers:

Meter(s)

F2530

Ref. No.	Part No.	Description	Spec Code	Quantity-ER650			
				'09	'10	'11	
				C9F	CAF	CBF	

14091	14091-1588-G3	COVER,METER,P.WHITE				1
14091A	14091-1588-H8	COVER,METER,EBONY			1	
14091B	14091-1588-15Q	COVER,METER,M.D.BLACK		1		
14091C	14091-1588-15S	COVER,METER,P.S.WHITE		1		
14091D	14091-1588-15T	COVER,METER,C.B.ORANGE		1		
14091E	14091-1588-15V	COVER,METER,M.F.S.BLACK			1	
14091F	14091-1588-15Z	COVER,METER,M.S.BLACK				1
14091G	14091-1588-35A	COVER,METER,M.F.S.GREEN				1
14091H	14091-1588-848	COVER,METER,P.B.ORANGE		1		
14091I	14091-1713	COVER,METER,LWR		1	1	1
25023	25023-0046	COVER-METER CASE		1	1	1
25031	25031-0222	METER-ASSY,KPH				
	L-----		WV	1	1	
25031A	25031-0229	METER-ASSY,MPH				
	L-----		UK	1	1	
25031B	25031-0295	METER-ASSY,KPH				
	L-----		WV			1
25031C	25031-0296	METER-ASSY,MPH				
	L-----		UK			1
28011	28011-0121	METER,SPEED&LCD				
	L-----		WV	1	1	
28011A	28011-0122	METER,SPEED&LCD				
	L-----		UK	1	1	
28011B	28011-0157	METER,SPEED&LCD				
	L-----		WV			1
28011C	28011-0158	METER,SPEED&LCD				
	L-----		UK			1
92009	92009-1197	SCREW,TAPPING,5X14		3	3	3
92009A	92009-1391	SCREW,TAPPING,3X16		9	9	9
92009B	92009-1593	SCREW,TAPPING,4X14		2	2	2
92022	92022-1405	WASHER,5.5X20X1.2		3	3	3
92160	92160-1167	DAMPER		3	3	3
92161	92161-0354	DAMPER		3	3	3

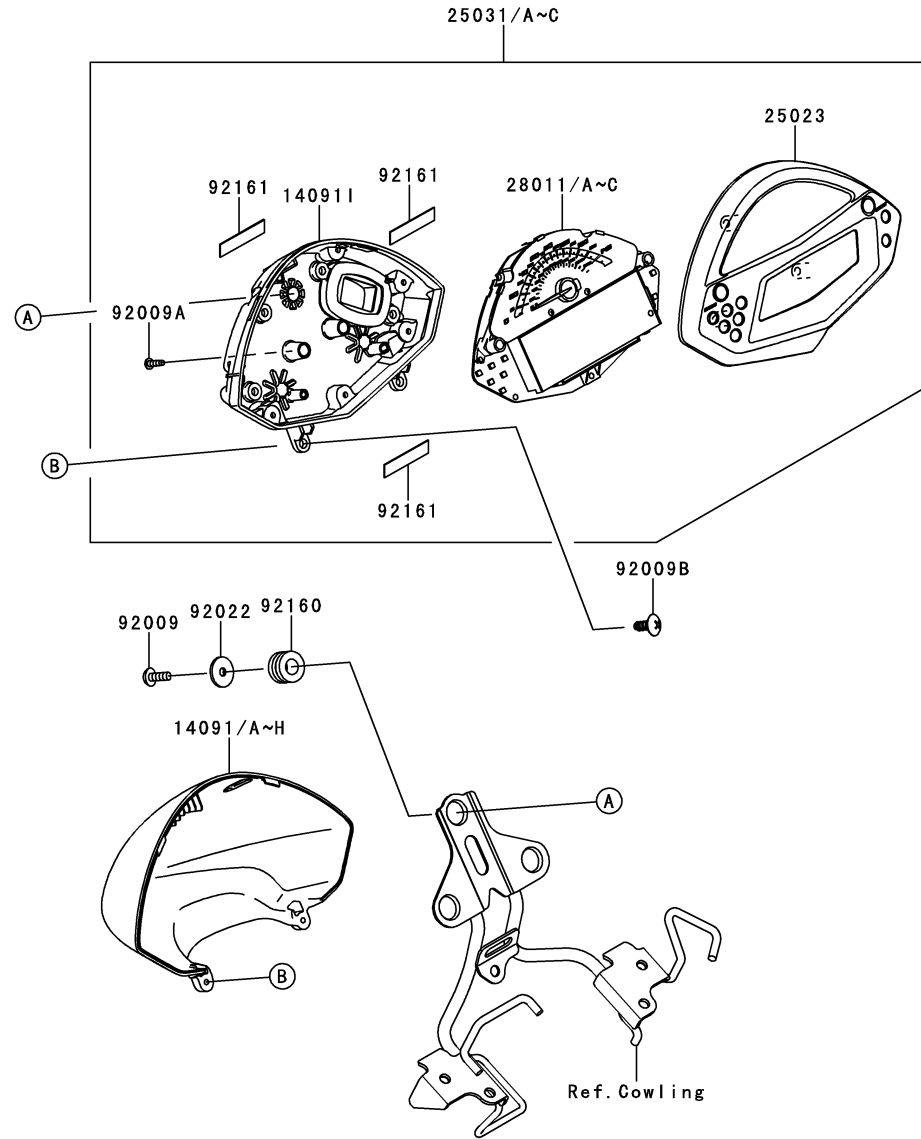

This catalog covers:

'09~'11 ER650 C9F/CAF/CBF Chassis

GRID NO.

F-13

This grid covers:

Cables

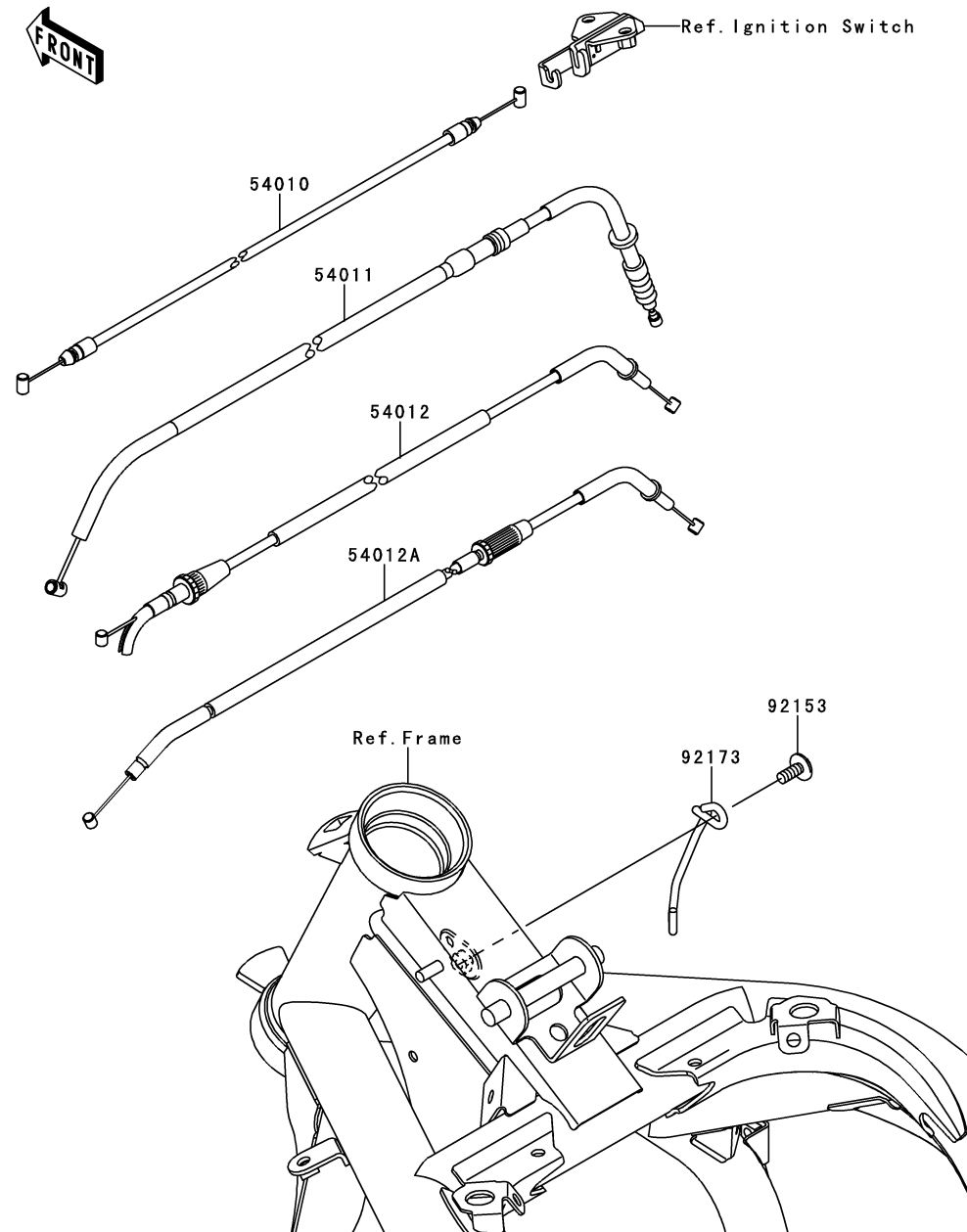

Ref. No.	Part No.	Description	Spec Code	Quantity-ER650			
				'09	'10	'11	
				C9F	CAF	CBF	
54010	54010-0096	CABLE,SEAT LOCK	1	1	1		
54011	54011-0098	CABLE-CLUTCH	1	1	1		
54012	54012-0240	CABLE-THROTTLE,OPENING	1	1	1		
54012A	54012-0241	CABLE-THROTTLE,CLOSING	1	1	1		
92153	92153-1446	BOLT,SOCKET,6X14	1	1	1		
92173	92173-0005	CLAMP	1	1	1		

This catalog covers:

'09~'11 ER650 C9F/CAF/CBF Chassis

GRID NO.

F-14

This grid covers:

Side Covers/Chain Cover

F2610

Ref. No.	Part No.	Description	Spec Code	Quantity-ER650		
				'09	'10	'11
				C9F	CAF	CBF

36001	36001-0143	COVER-SIDE,LH	1	1	1
36001A	36001-0144	COVER-SIDE,RH	1	1	1
36014	36014-0043	CASE-CHAIN	1	1	1
39156	39156-0320	PAD	2	2	2
92039	92039-0023	RIVET	3	3	3
92151	92151-1654	BOLT,SOCKET,6X14	3	3	3
92160	92160-1613	DAMPER	4	4	4

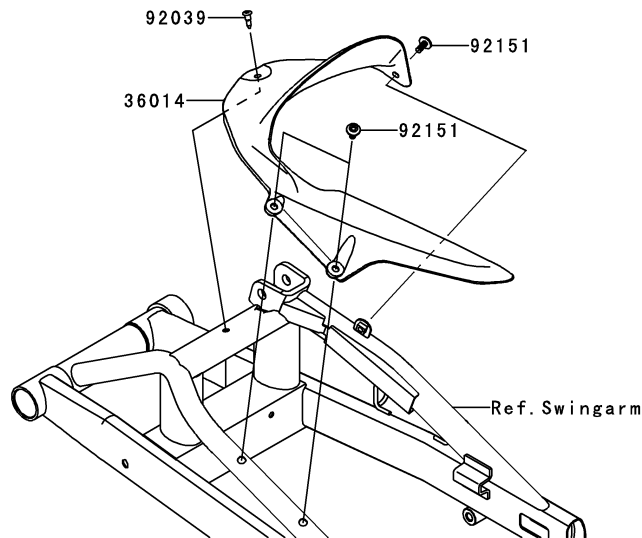
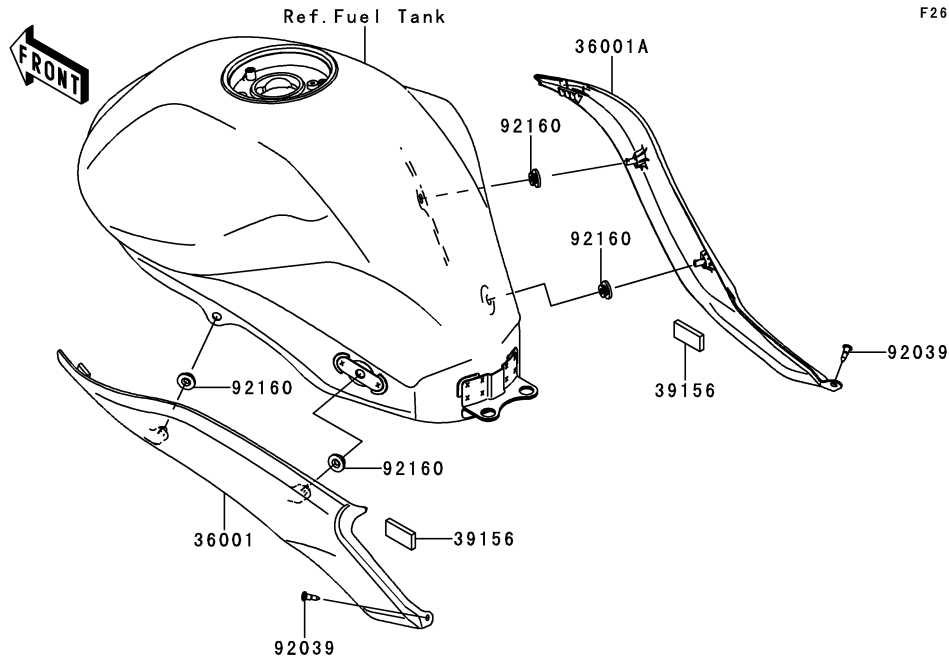

This catalog covers:

'09~'11 ER650 C9F/CAF/CBF Chassis

GRID NO.

G-3

This grid covers:

Seat Cover

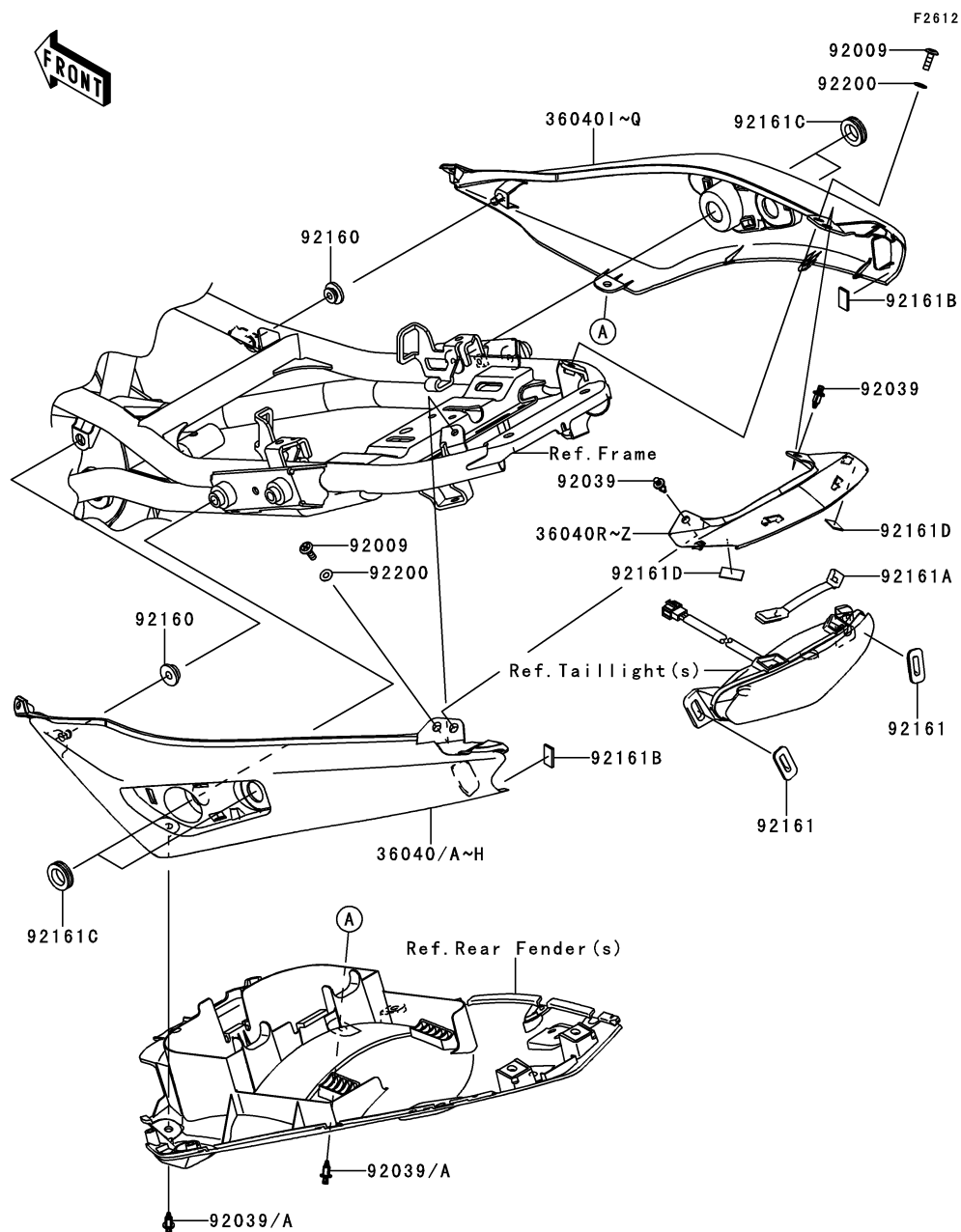

Ref. No.	Part No.	Description	Spec Code	Quantity-ER650			
				'09	'10	'11	
				C9F	CAF	CBF	
36040	36040-0081-G3	COVER-TAIL,LH,P.WHITE			1		
36040A	36040-0081-H8	COVER-TAIL,LH,EBONY		1			
36040B	36040-0081-15Q	COVER-TAIL,LH,M.D.BLACK	1				
36040C	36040-0081-15S	COVER-TAIL,LH,P.S.WHITE	1				
36040D	36040-0081-15T	COVER-TAIL,LH,C.B.ORANGE	1				
36040E	36040-0081-15Z	COVER-TAIL,LH,M.S.BLACK			1		
36040F	36040-0081-35A	COVER-TAIL,LH,M.F.S.GREEN			1		
36040G	36040-0081-777	COVER-TAIL,LH,L.GREEN		1			
36040H	36040-0081-848	COVER-TAIL,LH,P.B.ORANGE		1			
36040I	36040-0082-G3	COVER-TAIL,RH,P.WHITE			1		
36040J	36040-0082-H8	COVER-TAIL,RH,EBONY			1		
36040K	36040-0082-15Q	COVER-TAIL,RH,M.D.BLACK	1				
36040L	36040-0082-15S	COVER-TAIL,RH,P.S.WHITE	1				
36040M	36040-0082-15T	COVER-TAIL,RH,C.B.ORANGE	1				
36040N	36040-0082-15Z	COVER-TAIL,RH,M.S.BLACK			1		
36040O	36040-0082-35A	COVER-TAIL,RH,M.F.S.GREEN			1		
36040P	36040-0082-777	COVER-TAIL,RH,L.GREEN		1			
36040Q	36040-0082-848	COVER-TAIL,RH,P.B.ORANGE		1			
36040R	36040-0083-G3	COVER-TAIL,CNT,P.WHITE			1		
36040S	36040-0083-H8	COVER-TAIL,CNT,EBONY			1		
36040T	36040-0083-15Q	COVER-TAIL,CNT,M.D.BLACK	1				
36040U	36040-0083-15S	COVER-TAIL,CNT,P.S.WHITE	1				
36040V	36040-0083-15T	COVER-TAIL,CNT,C.B.ORANGE	1				
36040W	36040-0083-15Z	COVER-TAIL,CNT,M.S.BLACK			1		
36040X	36040-0083-35A	COVER-TAIL,CNT,M.F.S.GREEN			1		
36040Y	36040-0083-777	COVER-TAIL,CNT,L.GREEN			1		
36040Z	36040-0083-848	COVER-TAIL,CNT,P.B.ORANGE		1			
92009	92009-1909	SCREW,5X16	2	2	2		
92039	92039-0023	RIVET	2	2	4		
92039A	92039-1283	RIVET	2	2			
92160	92160-1613	DAMPER	2	2	2		
92161	92161-0624	DAMPER,TAIL LAMP L&R	2	2	2		
92161A	92161-0625	DAMPER,TAIL LAMP UPP	1	1	1		
92161B	92161-0726	DAMPER	2	2	2		
92161C	92161-0765	DAMPER	4	4	4		
92161D	92161-0821	DAMPER,20X10X1	2	2	2		
92200	92200-1480	WASHER,NYLON,5.3X11.5X0.5	2	2	2		

This catalog covers:

'09~'11 ER650 C9F/CAF/CBF Chassis

GRID NO.

G-4

This grid covers:

Headlight(s)

F2710

Ref. No.	Part No.	Description	Spec Code	Quantity-ER650			
				'09	'10	'11	
				C9F	CAF	CBF	
23007	23007-0131	LENS-COMP,HEAD LAMP	1	1	1		
23008	23008-0085	SOCKET-ASSY,POSITION LAMP	2	2	2		
49016	49016-0058	COVER-SEAL,HEAD LAMP	2	2	2		
92001	92001-1773	BOLT,6X20	4	4	4		
92015	92015-1094	NUT,6MM	4	4	4		
92069	92069-0034	BULB,12V 55W,H11	2	2	2		
92069A	92069-1016	BULB,12V 5W	2	2	2		
92152	92152-0048	COLLAR	4	4	4		
92160	92160-1162	DAMPER	4	4	4		
132	132BB0625	BOLT-FLANGED-SMALL,6X25	4	4	4		

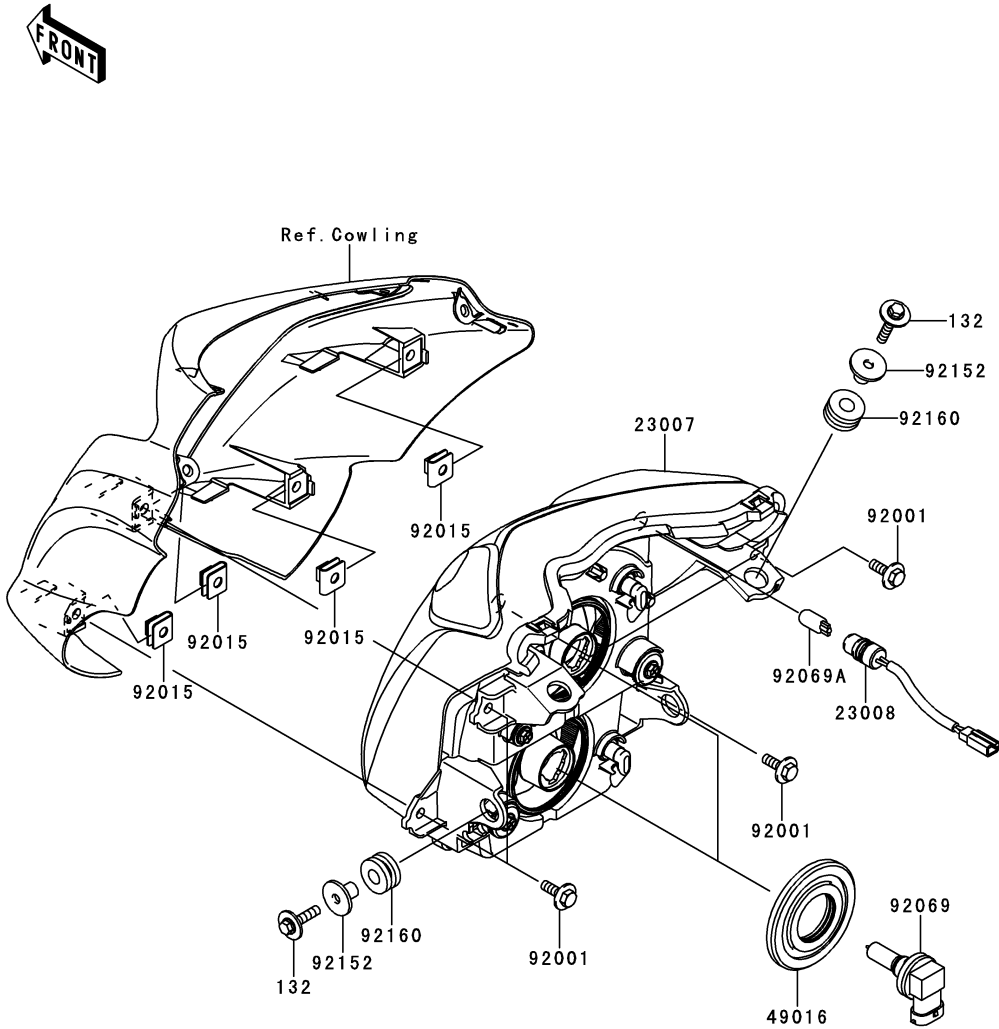

This catalog covers:

'09~'11 ER650 C9F/CAF/CBF Chassis

GRID NO.

G-5

This grid covers:

Taillight(s)

F2720

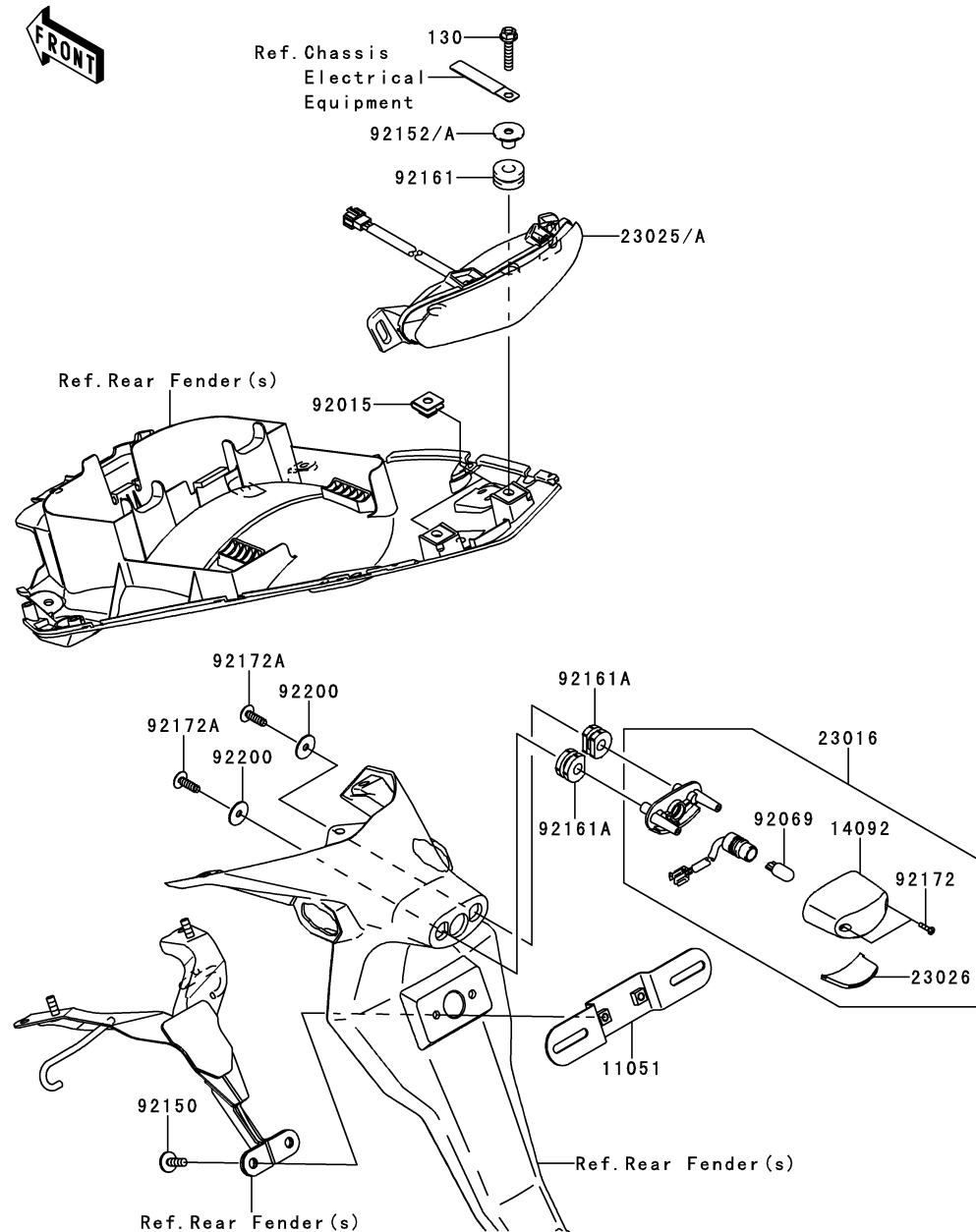

Ref. No.	Part No.	Description	Spec Code	Quantity-ER650			
				'09	'10	'11	
				C9F	CAF	CBF	
11051	11051-1503	BRACKET,LICENSE	1	1	1		
14092	14092-0001	COVER,LICENSE LAMP	1	1	1		
23016	23016-0033	LAMP-ASSY,LICENSE	1	1	1		
23025	23025-0054	LAMP-TAIL,LED	1				
23025A	23025-0066	LAMP-TAIL,LED		1	1		
23026	23026-0015	LENS,LICENSE LAMP	1	1	1		
92015	92015-1094	NUT,6MM	2	2	2		
92069	92069-1016	BULB,12V 5W	1	1	1		
92150	92150-1633	BOLT,FLANGED,6X20	2	2	2		
92152	92152-0365	COLLAR	2	2			
92152A	92152-0910	COLLAR,6.5X10X13.1				2	
92161	92161-0163	DAMPER	2	2	2		
92161A	92161-0776	DAMPER	2	2	2		
92172	92172-0343	SCREW,TAPPING,2.9X13	2	2	2		
92172A	92172-0427	SCREW,TAPPING,5X16	2	2	2		
92200	92200-0284	WASHER,5.5X20X1.2	2	2	2		
130	130BB0630	BOLT-FLANGED,6X30	2	2	2		

This catalog covers:

'09~'11 ER650 C9F/CAF/CBF Chassis

GRID NO.

G-6

This grid covers:

Turn Signals

F2730

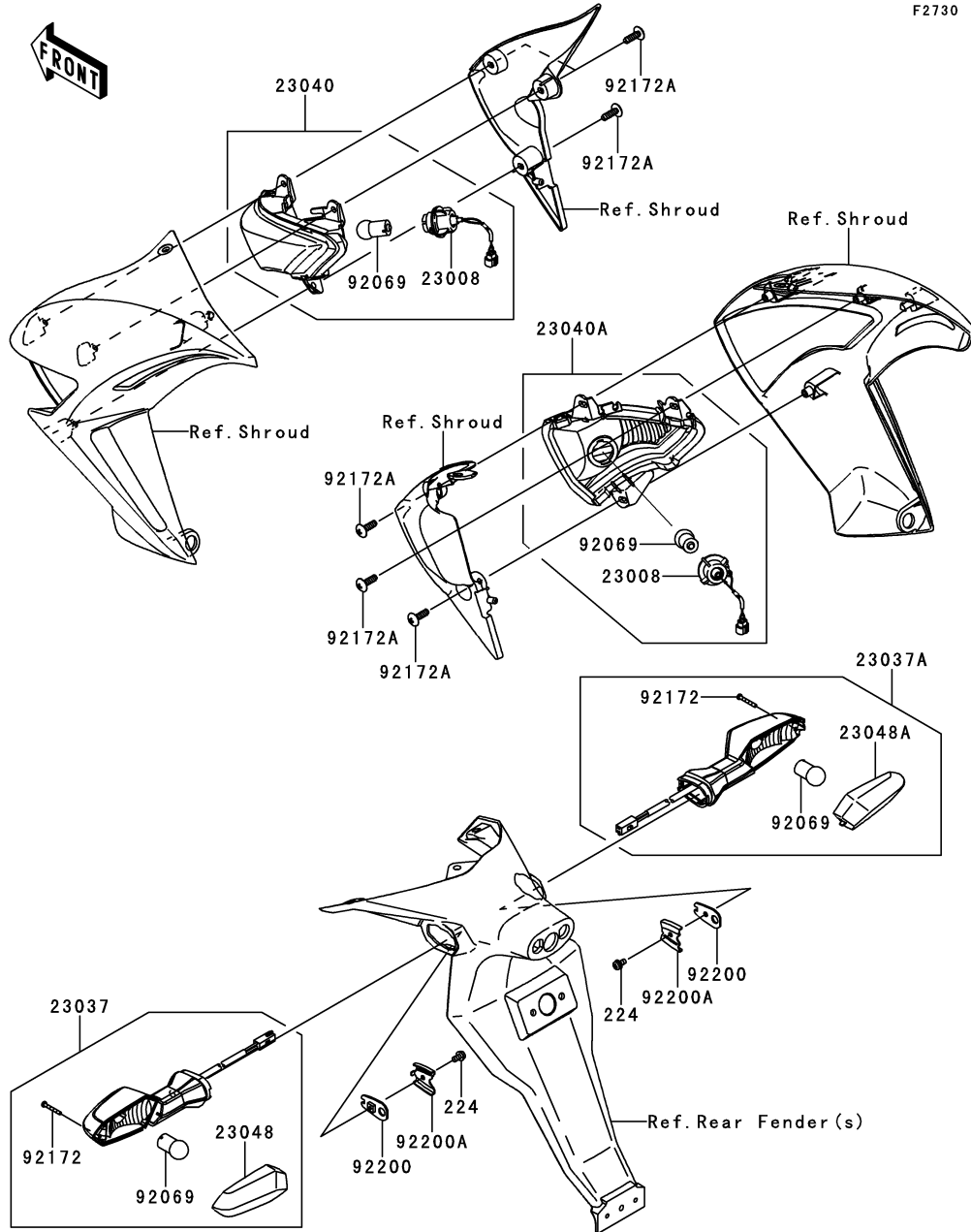

Ref. No.	Part No.	Description	Spec Code	Quantity-ER650		
				'09	'10	'11
				C9F	CAF	CBF
23008	23008-0101	SOCKET-ASSY,SIGNAL LAMP,FR	2	2	2	
23037	23037-0161	LAMP-ASSY-SIGNAL,RR,LH	1	1	1	
23037A	23037-0162	LAMP-ASSY-SIGNAL,RR,RH	1	1	1	
23040	23040-0097	LAMP-SIGNAL,FR,LH	1	1	1	
23040A	23040-0098	LAMP-SIGNAL,FR,RH	1	1	1	
23048	23048-0014	LENS-SIGNAL LAMP,RR,LH	1	1	1	
23048A	23048-0015	LENS-SIGNAL LAMP,RR,RH	1	1	1	
92069	92069-0024	BULB,12V 10W	4	4	4	
92172	92172-0395	SCREW,2.9X22	2	2	2	
92172A	92172-0427	SCREW,TAPPING,5X16	6	6	6	
92200	92200-0164	WASHER,SIGNAL LAMP	2	2	2	
92200A	92200-0165	WASHER,SIGNAL LAMP	2	2	2	
224	224AB0408	SCREW-PAN-WP-CROS,4X8	2	2	2	

This catalog covers:

'09~'11 ER650 C9F/CAF/CBF Chassis

GRID NO.

G-7

This grid covers:

Chassis Electrical Equipment

F2760

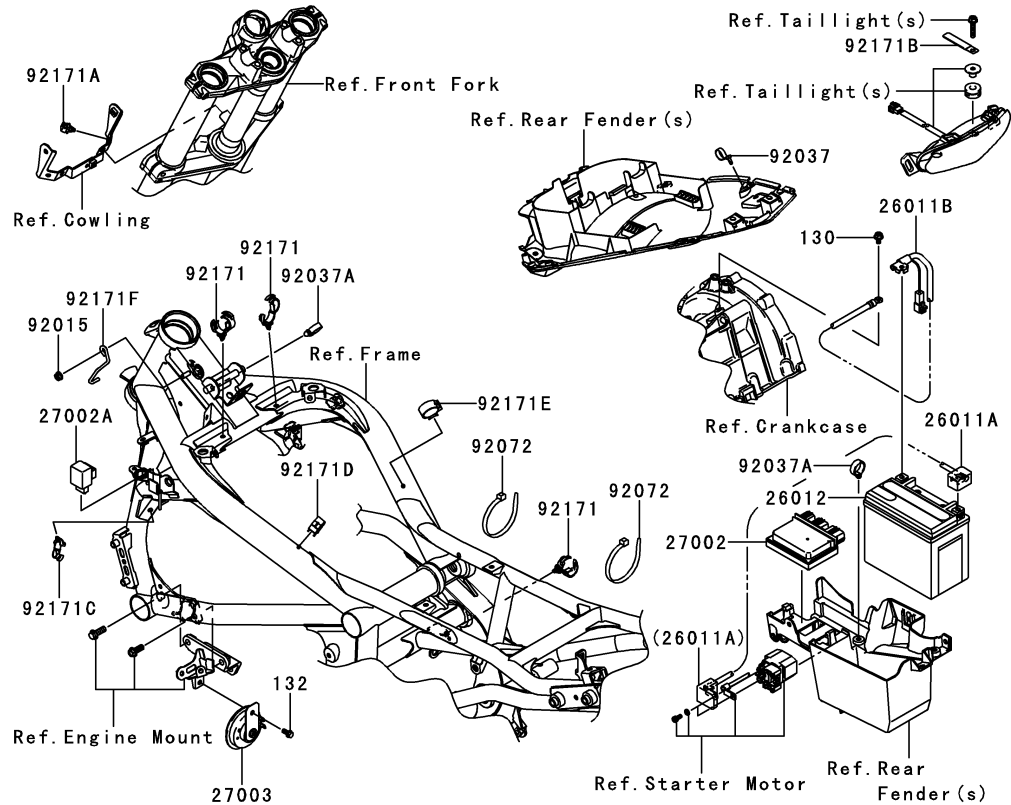
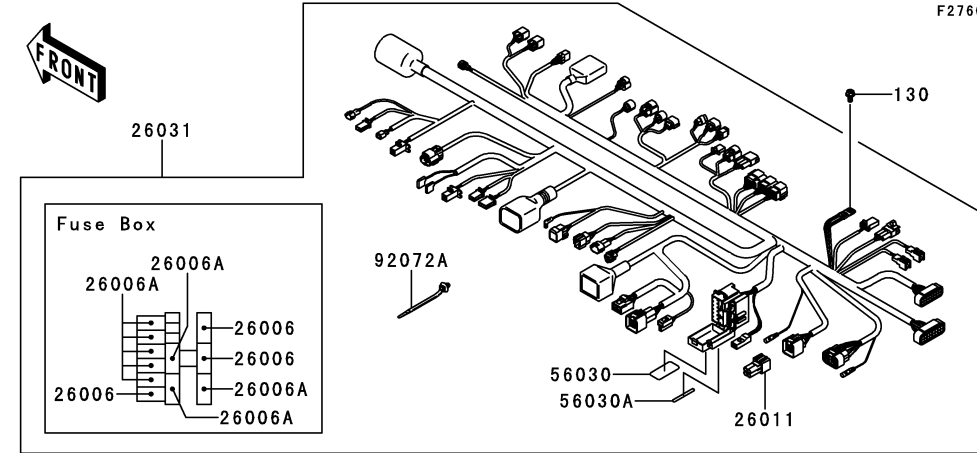

Ref. No.	Part No.	Description	Spec Code	Quantity-ER650		
				'09	'10	'11
				C9F	CAF	CBF
26006	26006-0001	FUSE,MINI BLADE,15A,BLUE	3	3	3	
26006A	26006-1078	FUSE,MINI BLADE,10A,RED	8	8	8	
26011	26011-0082	WIRE-LEAD	1	1	1	
26011A	26011-0247	WIRE-LEAD,BATTERY(+)	1	1	1	
26011B	26011-0250	WIRE-LEAD,BATTERY(-)	1	1	1	
26012	26012-0109	BATTERY,FTX12-BS,12V 10AH	1	1	1	
26031	26031-0670	HARNISS,MAIN	1	1	1	
27002	27002-0007	RELAY-ASSY	1	1	1	
27002A	27002-1097	RELAY-ASSY,SIGNAL LAMP	1	1	1	
27003	27003-0056	HORN	1	1	1	
56030	56030-0046	LABEL,FUSE BOX	1	1	1	
56030A	56030-0098	LABEL,FUSE BOX	1	1	1	
92015	92015-1233	NUT,FLANGED,6MM,BLACK	1	1	1	
92037	92037-1163	CLAMP,SPEED,L=58	1	1	1	
92037A	92037-1827	CLAMP,HOSE	2	2	2	
92072	92072-1197	BAND,L=365	2	2	2	
92072A	92072-1414	BAND	12	12	12	
92171	92171-0069	CLAMP,DIA=20	3	3	3	
92171A	92171-0640	CLAMP	1	1	1	
92171B	92171-0652	CLAMP	1	1	1	
92171C	92171-1415	CLAMP,DIA=13	1	1	1	
92171D	92171-1424	CLAMP,DIA=15	1	1	1	
92171E	92171-1559	CLAMP,DIA=25	1	1	1	
92171F	92171-1897	CLAMP	1	1	1	
130	130BA0612	BOLT-FLANGED,6X12	2	2	2	
132	132BB0612	BOLT-FLANGED-SMALL,6X12	1	1	1	

This catalog covers:

'09~'11 ER650 C9F/CAF/CBF Chassis

GRID NO.

G-8

This grid covers:

Ignition Switch

F2770

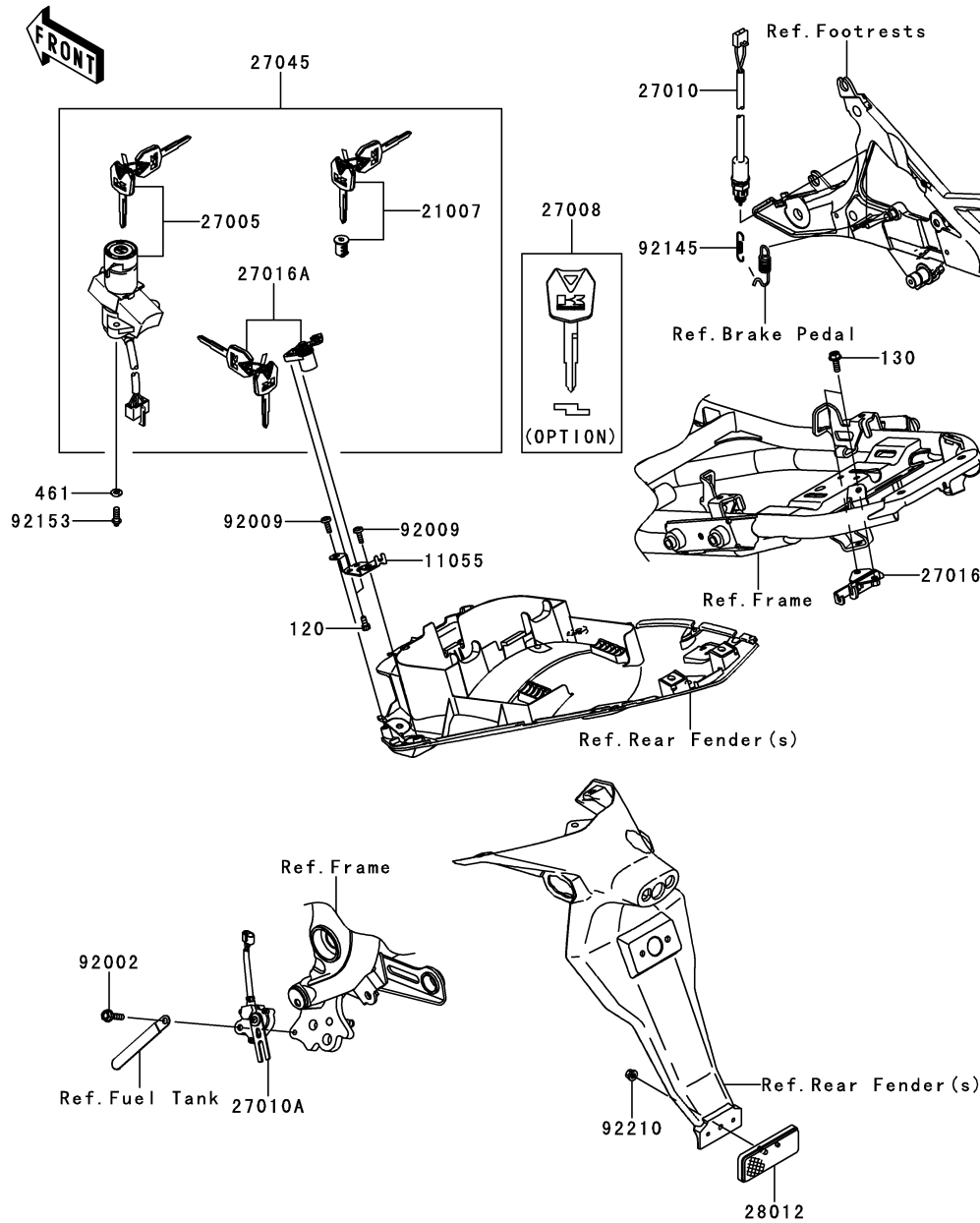

Ref. No.	Part No.	Description	Spec Code	Quantity-ER650			
				'09	'10	'11	
				C9F	CAF	CBF	
11055	11055-0590	BRACKET,SEAT LOCK	1	1	1		
21007	21007-5057	ROTOR,LOCK,TANK CAP	1	1	1		
27005	27005-5141	SWITCH-ASSY-IGNITION	1	1	1		
27008	27008-0030	KEY-LOCK,BLANK	1	1	1		
	(OPTION)						
27010	27010-0095	SWITCH,REAR BRAKE	1	1	1		
27010A	27010-0097	SWITCH,SIDE STAND	1	1	1		
27016	27016-1115	LOCK-ASSY,SEAT STRIKER	1	1	1		
27016A	27016-5309	LOCK-ASSY,SEAT	1	1	1		
27045	27045-5360	SWITCH-ASSY	1	1	1		
28012	28012-1077	REFLECTOR-REFLEX	1	1	1		
92002	92002-1582	BOLT,FLANGED,6X25	1	1	1		
92009	92009-3845	SCREW,6X14	2	2	2		
92145	92145-0724	SPRING,REAR BRAKE SWITCH	1	1	1		
92153	92153-0967	BOLT,TORX,6X16	2	2	2		
92210	92210-0007	NUT,FLANGED,5MM	1	1	1		
120	120CB0512	BOLT-SOCKET,5X12	2	2	2		
130	130BA0612	BOLT-FLANGED,6X12	2	2	2		
461	461DA0600	WASHER-SPRING,6MM	2	2	2		

This catalog covers:

'09~'11 ER650 C9F/CAF/CBF Chassis

GRID NO.

G-9

This grid covers:

Owner's Tools

F2810

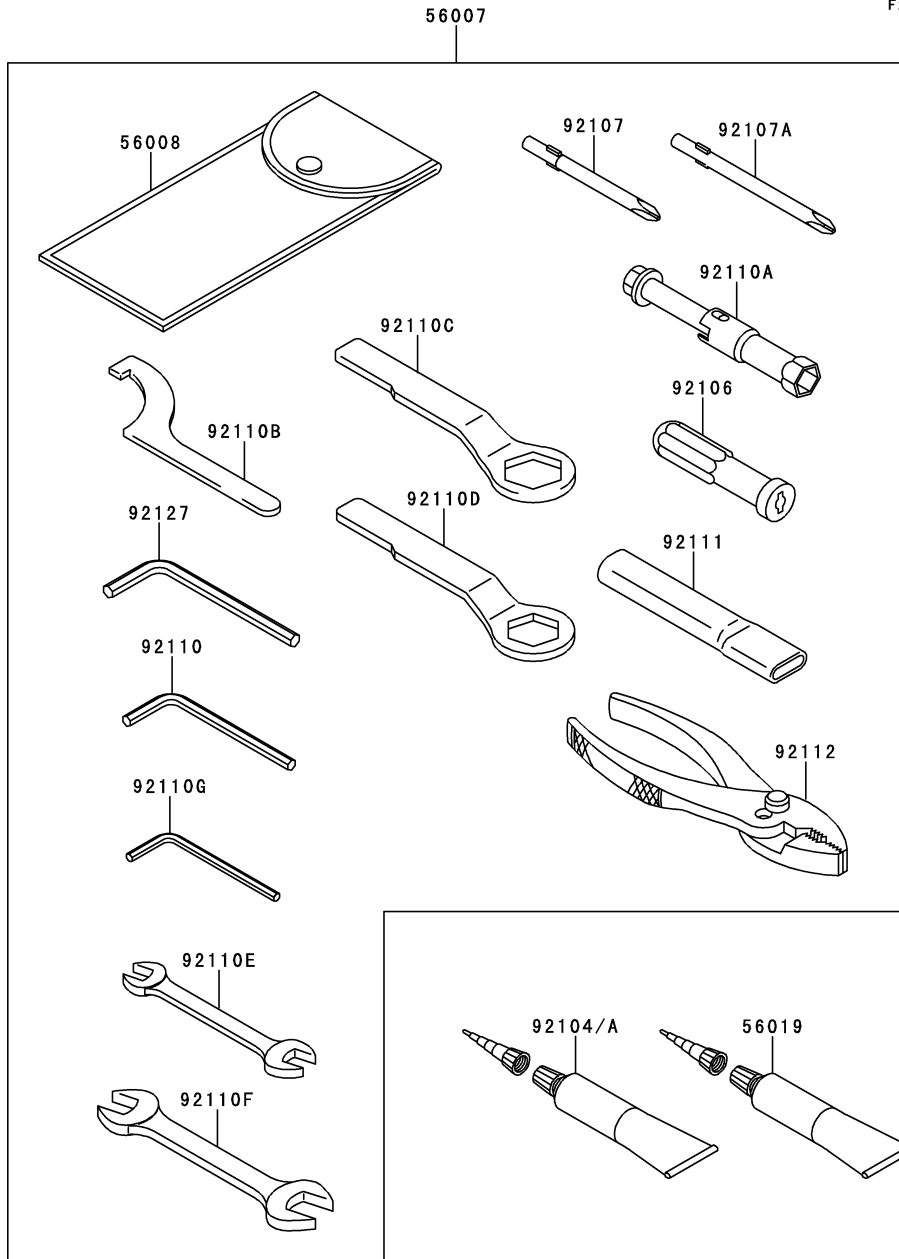

Ref. No.	Part No.	Description	Spec Code	Quantity-ER650			
				'09	'10	'11	
				C9F	CAF	CBF	
56007	56007-0026	TOOL-KIT	1	1	1		
56008	56008-1075	BAG, TOOL	1	1	1		
56019	56019-120	GASKET-LIQUID, TB1211, WHITE	1	1	1		
92104	92104-0004	GASKET-LIQUID, TB1211F, CLEAR	1	1	1		
92104A	92104-1064	GASKET-LIQUID, TB1216B, BLACK	1	1	1		
92106	92106-1001	GRIP-SCREW DRIVER	1	1	1		
92107	92107-005	TOOL-DRIVER, #3 PHILLIPS	1	1	1		
92107A	92107-1053	TOOL-DRIVER, #2 PHILLIPS	1	1	1		
92110	92110-1015	TOOL-WRENCH, ALLEN, 5MM	1	1	1		
92110A	92110-1132	TOOL-WRENCH, BOX, 16MM	1	1	1		
92110B	92110-1144	TOOL-WRENCH, HOOK	1	1	1		
92110C	92110-1147	TOOL-WRENCH, BOX END, 27MM	1	1	1		
92110D	92110-1148	TOOL-WRENCH, BOX END, 22MM	1	1	1		
92110E	92110-1152	TOOL-WRENCH, OPEN END, 10X12	1	1	1		
92110F	92110-1153	TOOL-WRENCH, OPEN END, 14X17	1	1	1		
92110G	92110-3703	TOOL-WRENCH, ALLEN, 4MM	1	1	1		
92111	92111-1051	TOOL-BAR, BOX END WRENCH	1	1	1		
92112	92112-1001	TOOL-PLIERS	1	1	1		
92127	92127-003	TOOL-WRENCH, ALLEN, 6MM	1	1	1		

This catalog covers:

'09~'11 ER650 C9F/CAF/CBF Chassis

GRID NO.

G-10

This grid covers:

Labels

F2860

Ref. No.	Part No.	Description	Spec Code	Quantity-ER650			
				'09	'10	'11	
				C9F	CAF	CBF	
56031	56031-1441	LABEL-MANUAL,ENGLISH/FRENCH					
	L-----		WV	1	1	1	
56033	56033-0250	LABEL-MANUAL,DAILY SAFETY					
	L-----		WV	1	1	1	
56033A	56033-0251	LABEL-MANUAL,DAILY SAFETY					
	L-----		UK	1	1	1	
56033B	56033-0252	LABEL-MANUAL,CHAIN					
	L-----		UK	1	1	1	
56033C	56033-0253	LABEL-MANUAL,CHAIN					
	L-----		WV	1	1	1	
56053	56053-0311	LABEL-SPECIFICATION,TIRE&LOAD					
	L-----		WV	1	1	1	
56053A	56053-0312	LABEL-SPECIFICATION,TIRE&LOAD					
	L-----		UK	1	1	1	
56070	56070-1143	LABEL,UNLEADED PETROL ONLY					
				1	1	1	

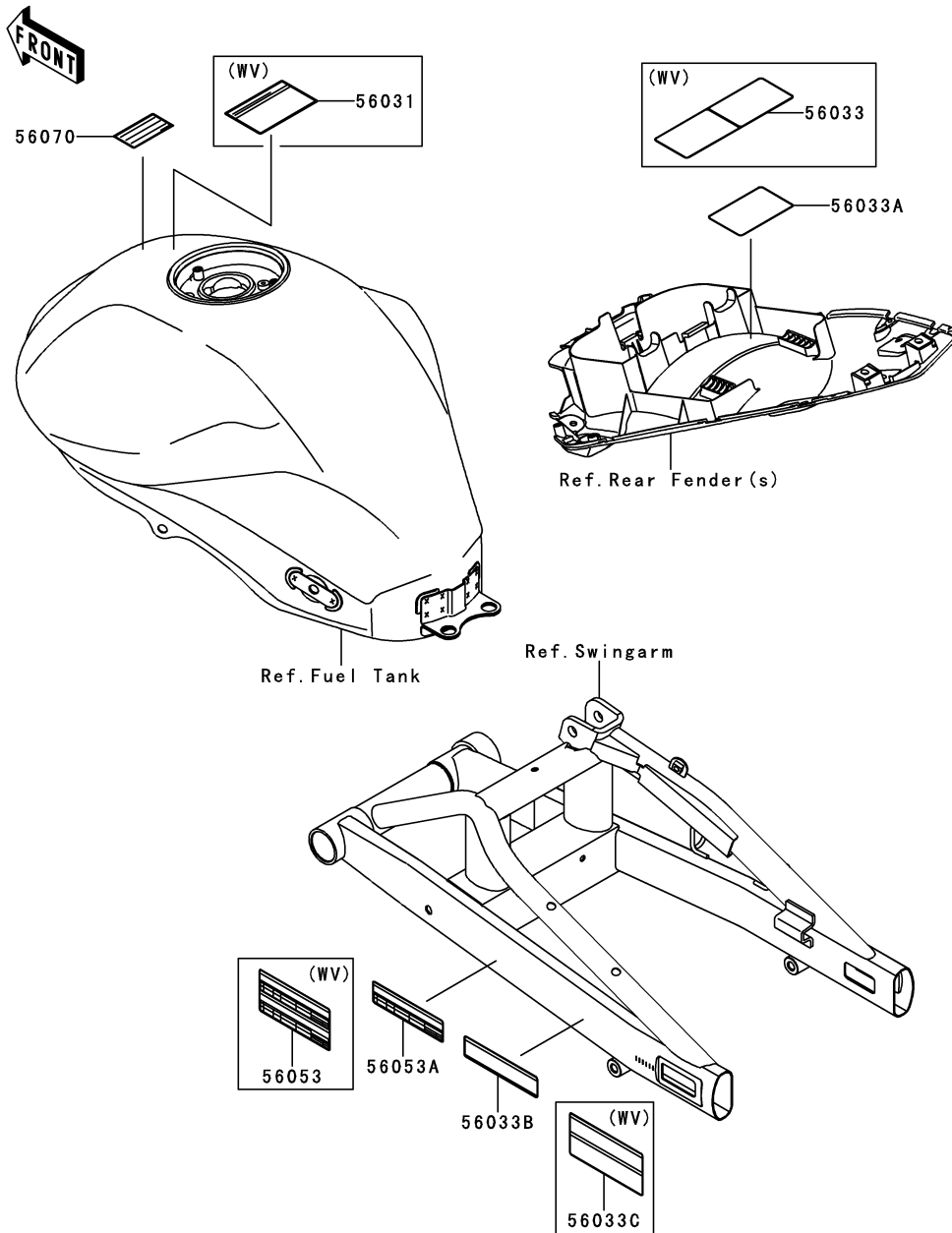

This catalog covers:

'09~'11 ER650 C9F/CAF/CBF Chassis

GRID NO.

G-11

This grid covers:

Decals(C.B.Orange)(P.S.White)(C9F)

F2861

Ref. No.	Part No.	Description	Spec Code	Quantity-ER650				
				'09	'10	'11		
				C9F	CAF	CBF		
56052	56052-0782	MARK,FUEL TANK,KAWASAKI						2
56054	56054-0297	MARK,SHROUD,ER-6N						2

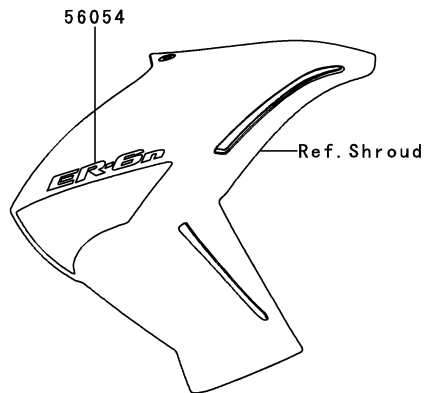
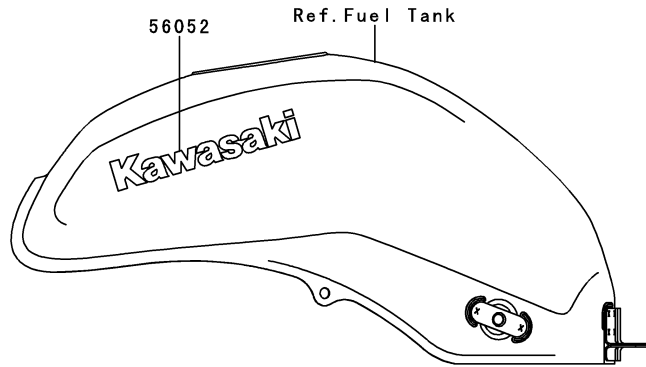

This catalog covers:

'09~'11 ER650 C9F/CAF/CBF Chassis

GRID NO.

G-12

This grid covers:

Decals(M.D.Black)(C9F)

F2861A

Ref. No.	Part No.	Description	Spec Code	Quantity-ER650			
				'09	'10	'11	
56054	56054-0296	MARK,SHROUD,ER-6N					2
56054A	56054-0482	MARK,FUEL TANK,KAWASAKI					2

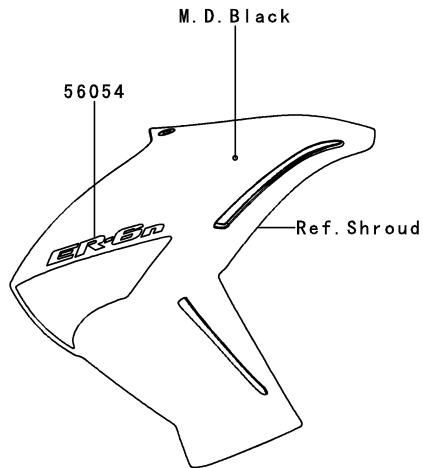
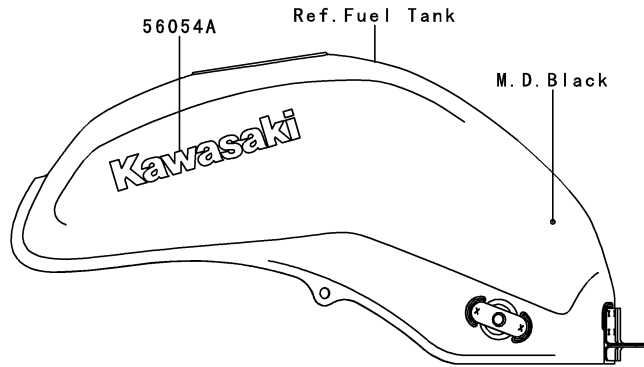

This catalog covers:

'09~'11 ER650 C9F/CAF/CBF Chassis

GRID NO.

G-13

This grid covers:

Decals(Ebony)(CAF)

F2861B

Ref. No.	Part No.	Description	Spec Code	Quantity-ER650			
				'09	'10	'11	
56054	56054-0293	MARK,FUEL TANK,KAWASAKI					2
56054A	56054-0528	MARK,SHROUD,ER-6N					2

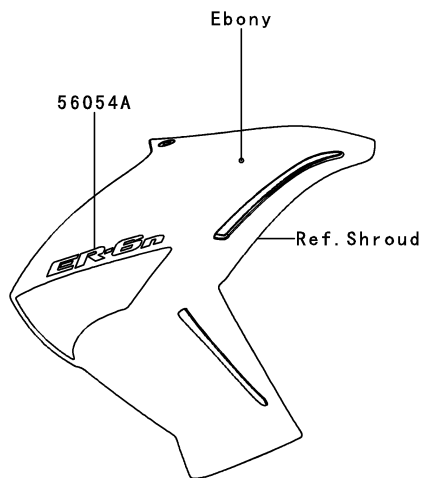
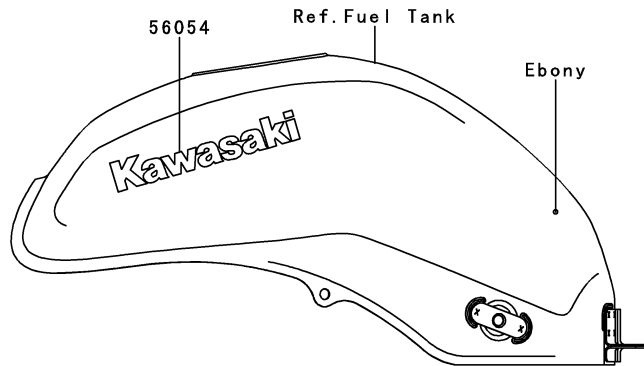

This catalog covers:

'09~'11 ER650 C9F/CAF/CBF Chassis

GRID NO.

G-14

This grid covers:

Decals(Orange)(CAF)(P.White)(CBF)

F28610

Ref. No.	Part No.	Description	Spec Code	Quantity-ER650			
				'09	'10	'11	
				C9F	CAF	CBF	
56054	56054-0526	MARK,FUEL TANK,KAWASAKI		2	2		
56054A	56054-0531	MARK,SHROUD,ER-6N		2	2		

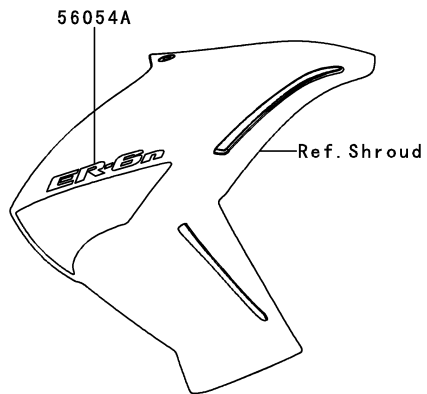
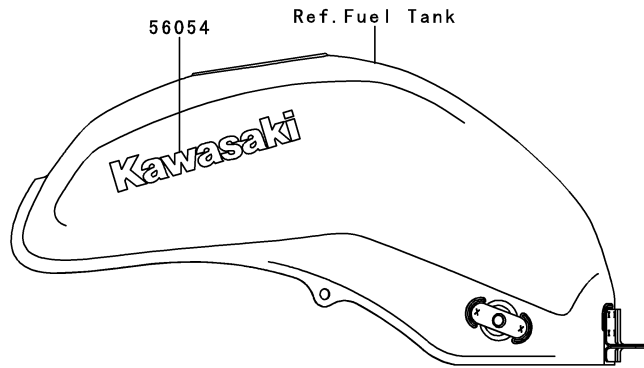

This catalog covers:

'09~'11 ER650 C9F/CAF/CBF Chassis

GRID NO.

H-3

This grid covers:

Decals(L.Green)(CAF)

F2861D

Ref. No.	Part No.	Description	Spec Code	Quantity-ER650			
				'09	'10	'11	
56054	56054-0526	MARK,FUEL TANK,KAWASAKI				2	
56054A	56054-0527	MARK,SHROUD,ER-6N				2	

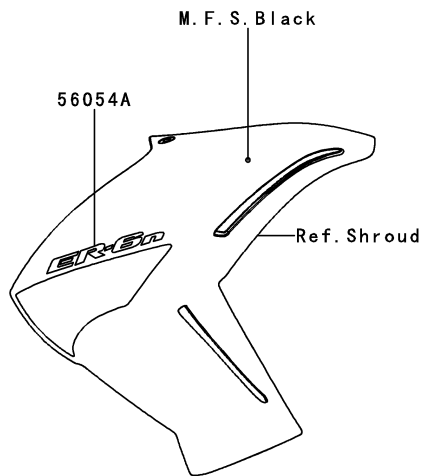
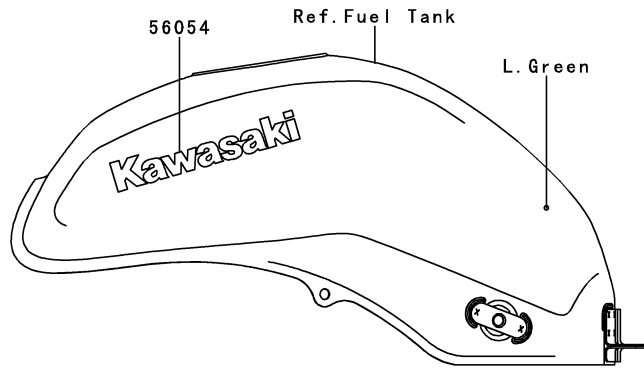

This catalog covers:

'09~'11 ER650 C9F/CAF/CBF Chassis

GRID NO.

H-4

This grid covers:

Decals(M.F.S.Green)(CBF)

F2861E

Ref. No.	Part No.	Description	Spec Code	Quantity-ER650			
				'09	'10	'11	
				C9F	CAF	CBF	
56054	56054-0526	MARK,FUEL TANK,KAWASAKI					2
56054A	56054-0662	MARK,SHROUD,ER-6N					2

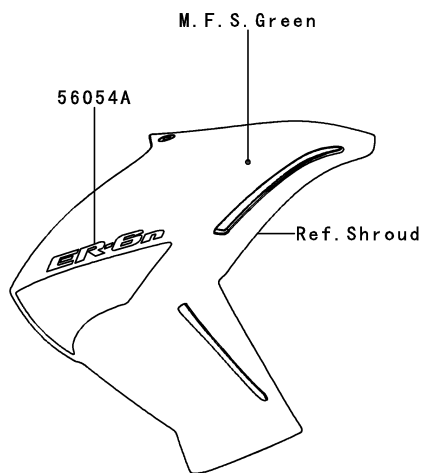
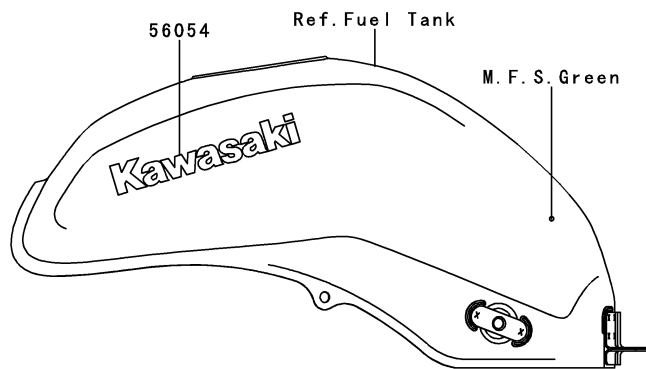

This catalog covers:

'09~'11 ER650 C9F/CAF/CBF Chassis

GRID NO.

H-5

This grid covers:

Decals(M.S.Black)(CBF)

F2861F

Ref. No.	Part No.	Description	Spec Code	Quantity-ER650			
				'09	'10	'11	
				C9F	CAF	CBF	
56054	56054-0537	MARK,FUEL TANK,KAWASAKI					2
56054A	56054-0661	MARK,SHROUD,ER-6N					2

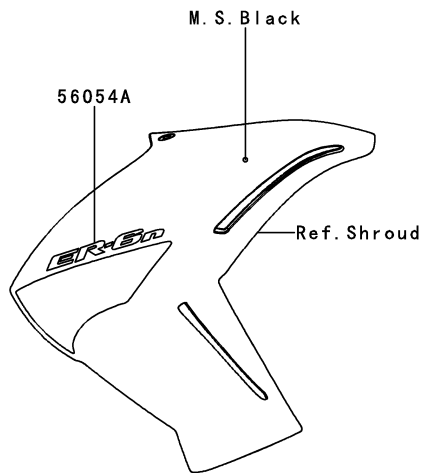
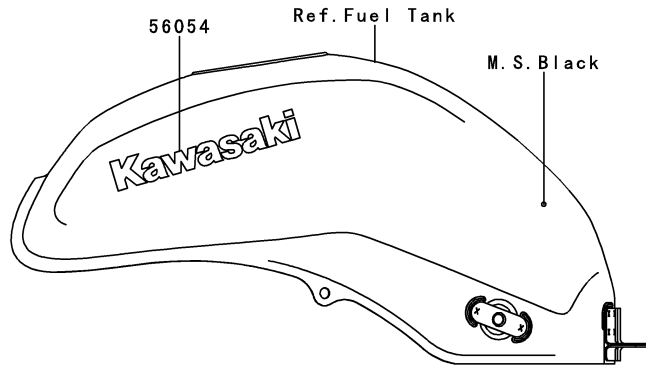

This catalog covers:

'09~'11 ER650 C9F/CAF/CBF Chassis

GRID NO.

H-6

This grid covers:

Cowling

F2871

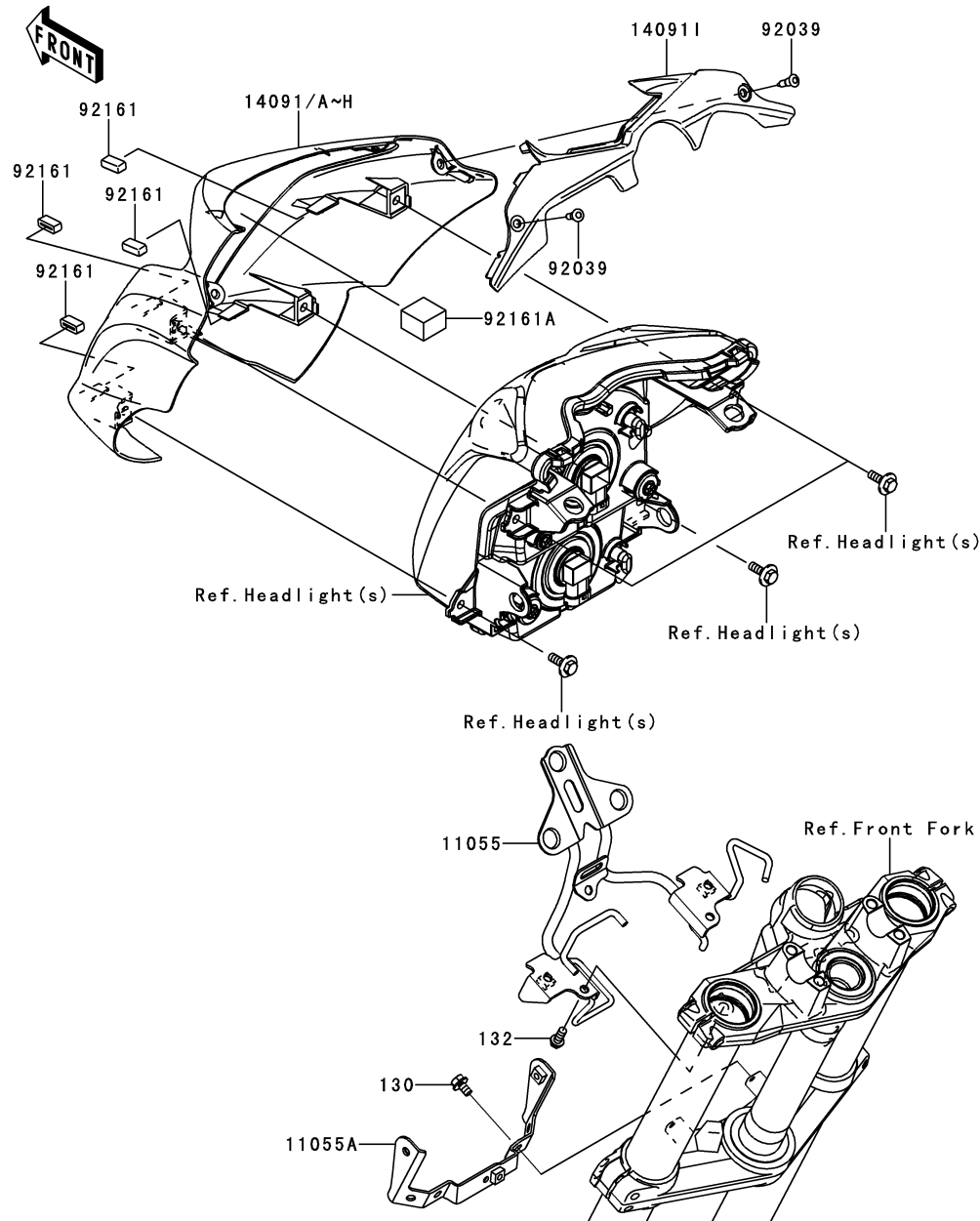

Ref. No.	Part No.	Description	Spec Code	Quantity-ER650			
				'09	'10	'11	
				C9F	CAF	CBF	
11055	11055-0591	BRACKET,HEAD LAMP,UPP	1	1	1		
11055A	11055-0592	BRACKET,HEAD LAMP,LWR	1	1	1		
14091	14091-1587-G3	COVER,HEAD LAMP,P.WHITE			1		
14091A	14091-1587-H8	COVER,HEAD LAMP,EBONY		1			
14091B	14091-1587-15Q	COVER,HEAD LAMP,M.D.BLACK	1				
14091C	14091-1587-15S	COVER,HEAD LAMP,P.S.WHITE	1				
14091D	14091-1587-15T	COVER,HEAD LAMP,C.B.ORANGE	1				
14091E	14091-1587-15Z	COVER,HEAD LAMP,M.S.BLACK				1	
14091F	14091-1587-35A	COVER,HEAD LAMP,M.F.S.GREEN				1	
14091G	14091-1587-777	COVER,HEAD LAMP,L.GREEN			1		
14091H	14091-1587-848	COVER,HEAD LAMP,P.B.ORANGE		1			
14091I	14091-1589	COVER,INNER,HEAD LAMP	1	1	1		
92039	92039-0023	RIVET	2	2	2		
92161	92161-0620	DAMPER	4	4	4		
92161A	92161-0792	DAMPER,T=13	1	1	1		
130	130BB0610	BOLT-FLANGED,6X10	2	2	2		
132	132BA0614	BOLT-FLANGED-SMALL,6X14	2	2	2		

This catalog covers:

'09~'11 ER650 C9F/CAF/CBF Chassis

GRID NO.

H-7

This grid covers:

Shroud

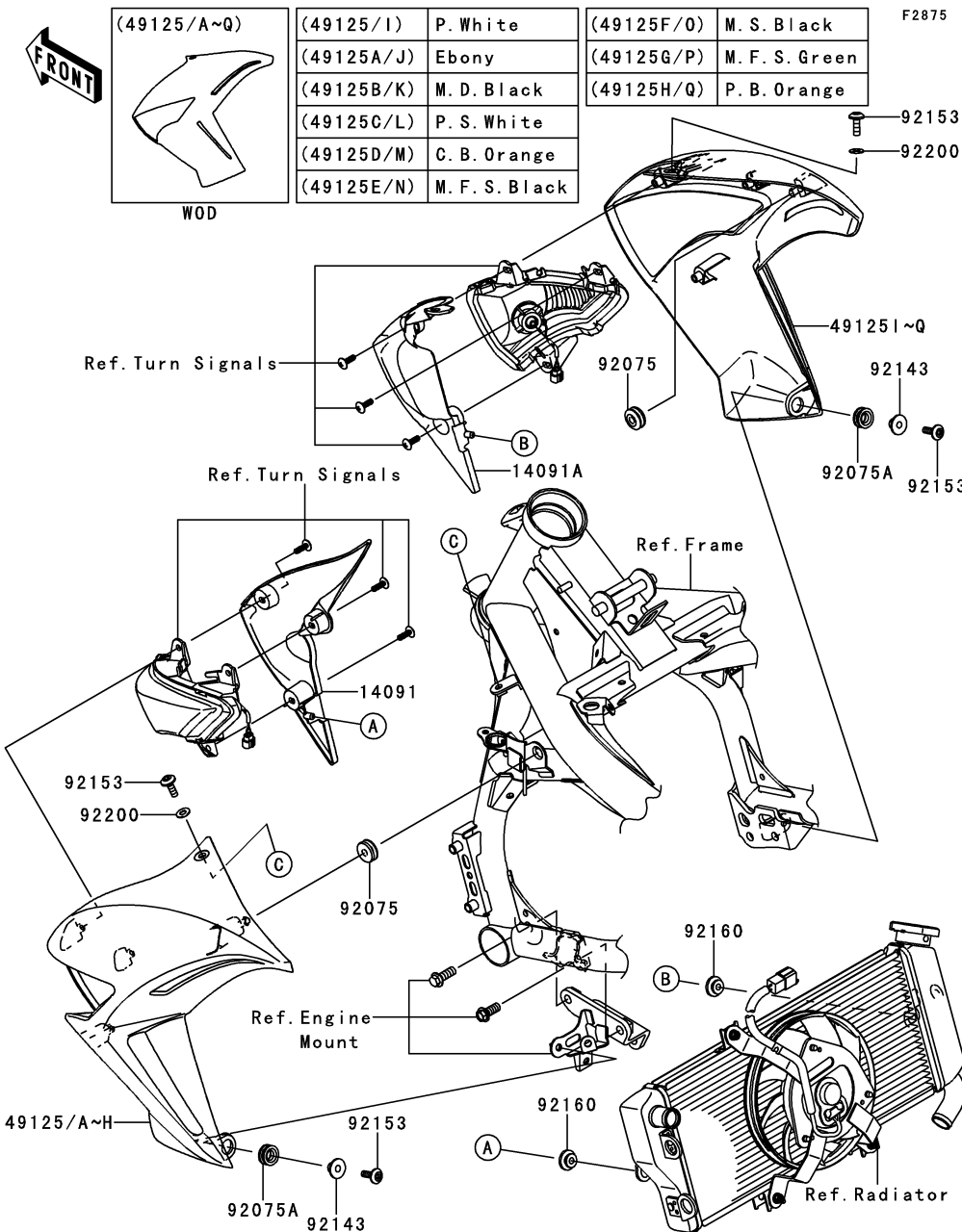

Ref. No.	Part No.	Description	Spec Code	Quantity-ER650			
				'09	'10	'11	
				C9F	CAF	CBF	
14091	14091-1590	COVER,SHROUD,LH		1	1	1	
14091A	14091-1591	COVER,SHROUD,RH		1	1	1	
49125	49125-0033-G3	SHROUD,LH,P.WHITE				1	
49125A	49125-0033-H8	SHROUD,LH,EBONY			1		
49125B	49125-0033-15Q	SHROUD,LH,M.D.BLACK		1			
49125C	49125-0033-15S	SHROUD,LH,P.S.WHITE		1			
49125D	49125-0033-15T	SHROUD,LH,C.B.ORANGE		1			
49125E	49125-0033-15V	SHROUD,LH,M.F.S.BLACK				1	
49125F	49125-0033-15Z	SHROUD,LH,M.S.BLACK					1
49125G	49125-0033-35A	SHROUD,LH,M.F.S.GREEN					1
49125H	49125-0033-848	SHROUD,LH,P.B.ORANGE				1	
49125I	49125-0034-G3	SHROUD,RH,P.WHITE					1
49125J	49125-0034-H8	SHROUD,RH,EBONY				1	
49125K	49125-0034-15Q	SHROUD,RH,M.D.BLACK		1			
49125L	49125-0034-15S	SHROUD,RH,P.S.WHITE		1			
49125M	49125-0034-15T	SHROUD,RH,C.B.ORANGE		1			
49125N	49125-0034-15V	SHROUD,RH,M.F.S.BLACK			1		
49125O	49125-0034-15Z	SHROUD,RH,M.S.BLACK					1
49125P	49125-0034-35A	SHROUD,RH,M.F.S.GREEN					1
49125Q	49125-0034-848	SHROUD,RH,P.B.ORANGE				1	
92075	92075-1067	DAMPER		2	2	2	
92075A	92075-1634	DAMPER		2	2	2	
92143	92143-1962	COLLAR		2	2	2	
92153	92153-0816	BOLT,6X18		4	4	4	
92160	92160-1613	DAMPER		2	2	2	
92200	92200-1388	WASHER,6.5X14X1		2	2	2	

This catalog covers:

'09~'11 ER650 C9F/CAF/CBF Chassis

GRID NO.

H-8

This grid covers:

Manual

F2920

Owner's Manual
(Local Procurement)

99976/A~E
99986/A/B

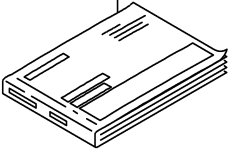

Ref. No.	Language
(99976/B/D)	English
	French
	German
(99976A/C/E)	Italian
	Spanish
	Dutch
(99986/A/B)	English

Service Manual

99901
99924
99953
99954
99955
99956

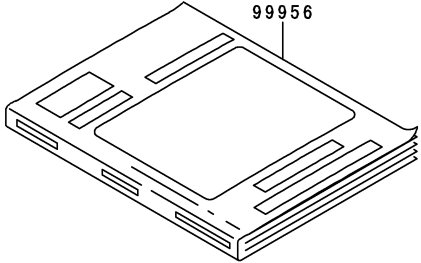

Ref. No.	Language
(99901)	Dutch
(99924)	English
(99953)	German
(99954)	French
(99955)	Italian
(99956)	Spanish

A&P Manual

99903
99931
99946
99950
99951
99952

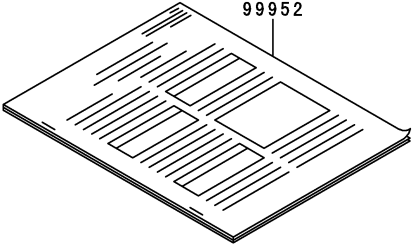

Ref. No.	Language
(99903)	Dutch
(99931)	English
(99946)	German
(99950)	French
(99951)	Italian
(99952)	Spanish

Ref. No.	Part No.	Description	Spec Code	Quantity-ER650				
				'09	'10	'11		
				C9F	CAF	CBF		
99901	99901-0014-01	SERVICE MANUAL,DUTCH	1	1	1			
99903	99903-0014-01	A&P MANUAL,DUTCH	1	1	1			
99924	99924-1418-02	SERVICE MANUAL,ENGLISH	1	1	1			
99931	99931-1506-01	A&P MANUAL,ENGLISH	1	1	1			
99946	99946-1054-01	A&P MANUAL,GERMAN	1	1	1			
99950	99950-1061-01	A&P MANUAL,FRENCH	1	1	1			
99951	99951-1043-01	A&P MANUAL,ITALIAN	1	1	1			
99952	99952-1030-01	A&P MANUAL,SPANISH	1	1	1			
99953	99953-1049-02	SERVICE MANUAL,GERMAN	1	1	1			
99954	99954-1063-02	SERVICE MANUAL,FRENCH	1	1	1			
99955	99955-1041-02	SERVICE MANUAL,ITALIAN	1	1	1			
99956	99956-1027-02	SERVICE MANUAL,SPANISH	1	1	1			
99976	99976-1426	OWNER'S MANUAL,EN/FR/DE	1					
99976A	99976-1427	OWNER'S MANUAL,IT/ES/NL	1					
99976B	99976-1563	OWNER'S MANUAL,EN/FR/DE		1				
99976C	99976-1564	OWNER'S MANUAL,IT/ES/NL			1			
99976D	99976-1580	OWNER'S MANUAL,EN/FR/DE				1		
99976E	99976-1581	OWNER'S MANUAL,IT/ES/NL				1		
99986	99986-1450	OWNER'S MANUAL,ENGLISH	1					
99986A	99986-1555	OWNER'S MANUAL,ENGLISH		1				
99986B	99986-1577	OWNER'S MANUAL,ENGLISH				1		

This catalog covers:

'09~'11 ER650 C9F/CAF/CBF

GRID NO.

This grid covers:

L-13 Numerical Parts Index

Part No.	Grid No.	Part No.	Grid No.	Part No.	Grid No.	Part No.	Grid No.	Part No.	Grid No.	Part No.	Grid No.
11004-0064	B-3	12021-1130	B-4	13145-0020	B-14	14014-0019	B-13	16142-0058	D-4	26011-0082	G-7
11005-0114	B-5	12032-0009	B-8	13151-1102	C-7	14014-0020	B-13	16154-0037	C-12	26011-0205	D-3
11008-0182	B-3	12046-0040	C-12	13156-0130	C-3	14026-0071	C-7	16154-1115	C-12	26011-0247	G-7
11009-1145	D-6	12046-0041	B-9	13159-1056	F-6	14031-0096	C-7	16160-0110	C-12	26011-0250	G-7
11009-1325	F-9	12048-0038	B-9	13187-0017	B-12	14032-0115	C-7	16160-0181	D-6	26012-0109	G-7
11010-0156	B-6	12053-0051	B-9	13194-1083	D-3	14043-0008	C-8	16163-0138	C-9	26031-0670	G-7
11012-1084	D-6	12053-0059	B-9	13227-0023	D-4	14055-0037	C-4	16165-0001	C-4	27002-0007	G-7
11029-0011	B-6	12053-0071	C-12	13234-0043	B-11	14069-1004	F-10	18091-0502	B-7	27002-1097	G-7
11051-1503	G-5	12053-0075	B-9	13236-0169	F-4	14073-0210	B-6	180AA0616	F-3	27003-0056	G-7
11053-1739	C-7	120CA0818	C-13	13236-0170	C-3	14079-0064	B-6	18140-0002	B-7	27005-5141	G-8
11053-1812	F-10	120CB0512	G-8	13251-0010-KK	B-10	14091-1584	E-8	21003-0042	C-13	27008-0030	G-8
11054-0248	E-5	120CB0610	D-3	13262-0245	B-13	14091-1585	E-8	21007-0053	C-14	27010-0025	F-4
11055-0584	E-5	120CB0622	F-4	13262-0246	B-13	14091-1587-15Q	H-6	21007-0075	C-13	27010-0095	G-8
11055-0587	E-10	120CB0625	F-8	13262-0251	B-13	14091-1587-15S	H-6	21007-5057	G-8	27010-0097	G-8
11055-0590	G-8	120CC0830	F-8	13262-0252	B-13	14091-1587-15T	H-6	21039-0004	D-3	27010-0099	D-3
11055-0591	H-6	13001-0087	B-5	13262-0253	B-13	14091-1587-15Z	H-6	21040-0003	D-3	27010-1094	F-8
11055-0592	H-6	13002-0007	B-5	13262-0335	B-13	14091-1587-35A	H-6	21066-1127	C-13	27010-1313	C-4
11055-0843	E-10	13008-1196	B-5	13262-0337	B-13	14091-1587-777	H-6	21163-0040	D-3	27016-1115	G-8
11055-1106	B-7	13031-0097	B-10	13262-0338	B-13	14091-1587-848	H-6	21171-0028	C-14	27016-5309	G-8
11055-1107	B-7	13042-5002	F-8	13262-0447	B-13	14091-1587-G3	H-6	21175-0187	C-11	27045-5360	G-8
11055-1115	F-4	13070-0045	F-7	13262-0498	B-13	14091-1587-H8	H-6	21176-0009	C-11	28011-0121	F-12
11055-1116	F-4	13087-0046	B-12	13271-0575	C-4	14091-1588-15Q	F-12	21176-0026	C-11	28011-0122	F-12
11055-1122	B-4	13088-1105	B-12	13271-0577	C-4	14091-1588-15S	F-12	21176-0048	C-11	28011-0157	F-12
11055-1131	E-5	13089-0016	B-12	13271-0584	C-4	14091-1588-15T	F-12	21176-0065	C-7	28011-0158	F-12
11055-1137	E-5	13095-0115	B-12	13271-0626	B-14	14091-1588-15V	F-12	21176-0105	C-11	28012-1077	G-8
11060-1952	F-10	130BA0512	C-14	13271-0952	C-13	14091-1588-15Z	F-12	21176-0111	C-11	290Q0606	C-4
11061-0029	F-5	130BA0518	C-11	13271-1187	C-4	14091-1588-35A	F-12	220AB0525	F-8	311AA0600	E-10
11061-0105	B-4	130BA0612	E-5	13272-0573	F-4	14091-1588-848	F-12	220AB0540	F-8	318AB0800	E-6
11061-0107	D-4	130BA0612	G-7	13280-0134	C-8	14091-1588-G3	F-12	224AB0408	G-6	32085-0047	E-8
11061-0164	C-7	130BA0612	G-8	13280-0183	B-14	14091-1588-H8	F-12	23007-0131	G-4	32154-0661	C-4
11061-0165	C-7	130BA0620	C-13	13280-0192	B-14	14091-1589	H-6	23008-0085	G-4	32155-0029	C-12
11061-0166	C-7	130BA0620	C-7	13280-0224	C-4	14091-1590	H-7	23008-0101	G-6	32160-0318-10	E-3
11061-0167	C-8	130BA0622	D-5	13280-0301	D-3	14091-1591	H-7	23016-0033	G-5	32160-0318-26M	E-3
11061-0170	B-4	130BB0610	E-5	13280-0306	F-8	14091-1673	C-7	23025-0054	G-5	32190-0189	E-4
11061-0171	B-5	130BB0610	F-4	13280-0307	F-8	14091-1678	E-10	23025-0066	G-5	32190-0381	E-4
11061-0278	B-7	130BB0610	H-6	132BA0614	H-6	14091-1702	B-4	23026-0015	G-5	33001-0161-10	E-6
11061-0373	C-7	130BB0625	F-10	132BA0618	B-4	14091-1713	F-12	23037-0161	G-6	33001-0161-26M	E-6
11065-0018	C-9	130BB0630	G-5	132BB0612	B-4	14092-0001	G-5	23037-0162	G-6	33032-1142	E-6
11065-0120	B-6	130CD0835	B-7	132BB0612	G-7	16007-1228	B-8	23040-0097	G-6	33040-0025	E-6
11065-0257-458	E-5	13102-0037	B-12	132BB0622	E-5	16014-0002	C-9	23040-0098	G-6	33040-0026-458	E-6
11065-0258-10	E-6	13107-0156	C-12	132BB0625	G-4	16065-0024	B-3	23048-0014	G-6	34024-0096	E-11
11065-0258-26M	E-6	13107-1106	D-3	132BB0630	C-7	16073-3707	C-9	23048-0015	G-6	34028-0127	E-8
11065-0264-458	E-5	13116-0032	F-4	13116-0032	E-4	16085-0074	D-3	25023-0046	F-12	34028-0128	E-8
11065-0281	C-7	13116-0035	B-12	132BC0630	C-7	16085-0076	D-3	25031-0222	F-12	34028-0129	E-8
11065-0286	B-4	13127-0028	B-13	132BC0630	D-4	16097-0004	C-12	25031-0229	F-12	34028-0130	E-8
112AB0645	F-8	13128-0020	B-13	132BC0670	C-7	16115-1053	C-7	25031-0295	F-12	34028-1430	E-8
12004-0015	B-8	13140-0025	B-14	13320-0019	C-3	16126-0019	B-6	25031-0296	F-12	35004-0110-15Q	E-9
12005-0035	B-8	13140-0026	B-14	14001-0140	C-4	16126-1140	E-12	26006-0001	G-7	35004-0110-15S	E-9
12009-1091	B-8	13141-0018	B-14	14013-1004	C-4	16130-1058	C-12	26006-1006	D-3	35004-0110-15T	E-9
12011-1053	B-8	13144-0024	B-13	14014-0018	B-14	16142-0024	C-12	26006-1078	G-7	35004-0110-15V	E-9

This catalog covers:

'09~'11 ER650 C9F/CAF/CBF

GRID NO.

L-14

This grid covers:

Numerical Parts Index

Part No.	Grid No.	Part No.	Grid No.	Part No.	Grid No.	Part No.	Grid No.	Part No.	Grid No.	Part No.	Grid No.
35004-0110-15Z	E-9	39178-0073	B-7	43049-1055	F-5	46075-0098	E-5	49125-0034-35A	H-7	56053-0311	G-10
35004-0110-35A	E-9	39193-0029	C-4	43049-1096	F-5	46075-1144	F-8	49125-0034-848	H-7	56053-0312	G-10
35004-0110-848	E-9	39193-0031	C-4	43049-1097	F-7	46076-0052	F-8	49125-0034-G3	H-7	56054-0293	G-13
35004-0110-G3	E-9	39193-0032	C-4	43056-1054	F-5	46091-0159	F-8	49125-0034-H8	H-7	56054-0296	G-12
35004-0110-H8	E-9	39193-0033	C-4	43056-1054	F-7	46091-0160	F-8	51044-0029	C-10	56054-0297	G-11
35004-0111	E-9	39193-0046	C-4	43057-003	F-5	46092-0031	F-8	51049-0039	F-10	56054-0482	G-12
35019-0075	E-10	41009-0190	E-12	43057-003	F-7	461DA0600	G-8	51086-5160-H8	F-10	56054-0526	G-14
35023-0142	E-10	41009-0191	E-12	43078-0052	D-6	461DB0600	D-3	51086-5168-15S	F-10	56054-0526	H-3
35023-0149	E-6	41068-0059	E-13	43078-1082	F-6	480J1300	C-3	51086-5168-15T	F-10	56054-0526	H-4
35023-0163	E-10	41068-0071	E-14	43080-0076-DJ	F-5	480J2900	B-13	51086-5273-15Q	F-10	56054-0527	H-3
35063-0522-18R	E-8	41073-0146-QT	E-14	43080-0077-DJ	F-5	482EA0100	E-8	51086-5375-35A	F-10	56054-0528	G-13
35063-0522-458	E-8	41073-0154-QT	E-13	43080-0085-DJ	F-7	482EA5000	E-8	51086-5375-777	F-10	56054-0531	G-14
35063-0523-18R	E-8	41075-0007	E-12	43082-0050	F-5	49002-1116	B-3	51086-5375-848	F-10	56054-0537	H-5
35063-0523-458	E-8	41075-0008	E-12	43082-0051	F-5	49006-1054	F-5	51086-5375-G3	F-10	56054-0661	H-5
36001-0143	F-14	41075-0009	E-12	43082-1213	F-7	49006-1054	F-7	51086-5378-15Z	F-10	56054-0662	H-4
36001-0144	F-14	41080-0161-11I	F-5	43084-003	F-5	49006-1095	F-5	52005-0071	C-7	56070-1143	G-10
36014-0043	F-14	41080-0161-32L	F-5	43084-003	F-7	49006-1095	F-7	52005-0076	F-10	59026-0018	C-14
36040-0081-15Q	G-3	41080-0162	F-7	43094-1053	F-8	49006-1212	F-7	53003-0128-MA	F-11	59256-0009	D-4
36040-0081-15S	G-3	41080-0200	F-7	43095-0193	F-6	49016-0049	D-5	53044-1174	E-5	59502-0041	D-5
36040-0081-15T	G-3	410AB0600	F-8	43095-0411	F-4	49016-0058	G-4	53044-1185	D-5	600A0500	B-13
36040-0081-15Z	G-3	410AB0800	E-6	43095-0412	F-4	49016-1044	F-4	53044-1249	F-10	601B6004UU	E-13
36040-0081-35A	G-3	411AA1200	E-7	43095-0413	F-6	49033-0011	C-9	53066-0205-MA	F-11	601B6204UU	E-14
36040-0081-777	G-3	42033-0028	E-14	44005-0066-26M	F-9	49034-0030	C-8	54010-0096	F-13	601B6205UU	E-14
36040-0081-848	G-3	42034-1143	C-13	44005-0066-32A	F-9	49040-0026	C-10	54011-0098	F-13	610A0408	B-14
36040-0081-G3	G-3	42036-0024	E-7	44006-0062-26M	F-9	49047-0029	B-14	54012-0240	F-13	610A0408	C-7
36040-0081-H8	G-3	42036-0066	E-6	44006-0062-32A	F-9	49047-0030	B-14	54012-0241	F-13	670B2012	E-7
36040-0082-15Q	G-3	42036-1251	E-14	44013-0055	F-9	49054-0001	D-6	55020-0192	E-6	670B2020	C-7
36040-0082-15S	G-3	42041-0061	E-14	44023-0072	F-9	49063-1055	D-4	55020-0220	E-10	670D1505	C-5
36040-0082-15T	G-3	42041-0087	E-14	44026-0133	F-9	49065-0011	C-12	55020-0461	E-8	670D1508	C-5
36040-0082-15Z	G-3	42045-018	E-14	44029-0005	F-9	49078-0065	B-8	55020-0462	E-8	670D1509	C-5
36040-0082-35A	G-3	43001-0104	F-3	44037-0106	F-9	49085-1078	D-5	55020-1691	F-9	670D1510	C-5
36040-0082-777	G-3	43010-1062	F-6	44039-0089	F-9	49091-0001	F-4	550AA2015	F-6	670D2014	C-5
36040-0082-848	G-3	43015-0116	F-4	44065-0014	F-9	49091-0001	F-6	550AA4035	E-14	671B2540	C-7
36040-0082-G3	G-3	43015-0122	F-6	44065-1115	F-9	49107-0074-6Z	B-7	551A0408	D-4	671B2560	E-14
36040-0082-H8	G-3	43020-0015	F-4	44071-0543-26M	F-9	49118-0042	B-9	551A0814	C-5	702A06690	F-10
36040-0083-15Q	G-3	43020-1094	F-6	44071-0543-32A	F-9	49118-0072	B-9	554DB0800	F-8	702A07100	F-10
36040-0083-15S	G-3	43020-1119	F-7	44071-0544-26M	F-9	49125-0033-15Q	H-7	555A0408	B-10	92001-1773	G-4
36040-0083-15T	G-3	43022-1010	F-4	44071-0544-32A	F-9	49125-0033-15S	H-7	56001-0125	F-8	92002-1143	B-3
36040-0083-15Z	G-3	43026-0019	F-4	45014-0223-458	E-7	49125-0033-15T	H-7	56001-0126	F-8	92002-1154	D-4
36040-0083-35A	G-3	43026-1051	F-6	45014-0298-458	E-7	49125-0033-15V	H-7	56007-0026	G-9	92002-1322	F-4
36040-0083-777	G-3	43027-0008	F-4	45014-0298-VM	E-7	49125-0033-15Z	H-7	56008-1075	G-9	92002-1323	F-4
36040-0083-848	G-3	43027-1051	F-6	46003-0152-10	F-8	49125-0033-35A	H-7	56019-120	G-9	92002-1344	C-12
36040-0083-G3	G-3	43028-0015	F-4	46003-0152-26M	F-8	49125-0033-848	H-7	56030-0046	G-7	92002-1534	C-7
36040-0083-H8	G-3	43028-1057	F-6	46012-0059	F-8	49125-0033-G3	H-7	56030-0098	G-7	92002-1582	G-8
39061-0138	D-5	43034-0037	F-7	46012-0060	F-8	49125-0033-H8	H-7	56031-1441	G-10	92002-1796	B-14
39062-0254	D-6	43034-0049	F-4	46012-0061	F-8	49125-0034-15Q	H-7	56033-0250	G-10	92002-1796	C-12
39062-0255	D-6	43044-1110	F-7	46019-0001	F-8	49125-0034-15S	H-7	56033-0251	G-10	92002-1935	E-11
39062-0265	D-6	43044-1115	F-5	46075-0078	E-5	49125-0034-15T	H-7	56033-0252	G-10	92003-208	B-9
39076-0006	D-3	43044-1116	F-5	46075-0079	E-5	49125-0034-15V	H-7	56033-0253	G-10	92004-0024	C-4
39156-0320	F-14	43048-1052	F-5	46075-0097	E-5	49125-0034-15Z	H-7	56052-0782	G-11	92004-0025	B-3

This catalog covers:

'09~'11 ER650 C9F/CAF/CBF

GRID NO.

This grid covers:

L-15

Numerical Parts Index

Part No.	Grid No.	Part No.	Grid No.	Part No.	Grid No.	Part No.	Grid No.	Part No.	Grid No.	Part No.	Grid No.
92004-0028	E-14	92027-251	D-5	92049-0115	D-4	92069-1016	G-4	92139-0119	B-11	92151-1465	C-6
92005-1238	C-4	92027-251	F-10	92049-0130	E-13	92069-1016	G-5	92139-0120	B-13	92151-1599	F-10
92009-1134	F-8	92028-1449	B-13	92049-0131	E-3	92070-0014	C-14	92140-0008	E-8	92151-1605	E-8
92009-1197	F-12	92028-1903	B-10	92049-0132	E-6	92071-0024	D-3	92143-1087	B-7	92151-1605	E-9
92009-1360	C-7	92028-1904	B-10	92049-0133	E-7	92071-1115	D-5	92143-1196	B-7	92151-1654	B-7
92009-1375	B-13	92028-1905	B-10	92049-0137	E-3	92072-0012	C-9	92143-1379	F-8	92151-1654	F-14
92009-1375	B-14	92033-015	B-13	92049-0138	E-6	92072-0108	E-5	92143-1498	C-3	92151-1703	E-5
92009-1391	F-12	92033-1036	F-9	92049-0140	E-14	92072-1197	G-7	92143-1727	E-6	92151-1755	B-7
92009-1404	E-8	92033-1037	B-13	92049-1287	E-14	92072-1203	E-5	92143-1962	H-7	92151-1930	C-7
92009-1593	F-12	92033-1041	E-6	92049-1349	B-8	92072-1414	G-7	92144-1467	F-8	92151-1930	C-8
92009-1860	C-9	92033-1043	E-14	92049-1475	C-7	92075-015	F-10	92144-1719	F-7	92151-1937	C-4
92009-1909	G-3	92033-1186	F-6	92049-1501	C-4	92075-1067	E-8	92144-1818	E-11	92151-1937	D-3
92009-1984	B-6	92033-1247	B-3	92049-1519	C-7	92075-1067	H-7	92144-1831	F-5	92152-0048	G-4
92009-1984	C-11	92036-008	B-5	92055-0006	C-4	92075-125	F-10	92144-1832	F-5	92152-0087	E-13
92009-3845	G-8	92037-1163	G-7	92055-0016	C-11	92075-1634	H-7	92144-1844	F-5	92152-0300	B-13
92015-1094	G-4	92037-147	F-10	92055-0082	D-4	92075-1690	D-5	92145-0066	B-12	92152-0302	E-14
92015-1094	G-5	92037-1827	G-7	92055-0083	D-4	92075-1690	F-10	92145-0304	C-3	92152-0306	B-9
92015-1188	E-11	92039-0023	E-6	92055-0160	D-6	92075-209	E-5	92145-0326	C-3	92152-0365	G-5
92015-1188	E-4	92039-0023	F-14	92055-0185	C-10	92081-1033	B-12	92145-0703	C-3	92152-0662	E-7
92015-1191	F-8	92039-0023	G-3	92055-0195	B-4	92081-1833	F-3	92145-0723	E-8	92152-0707	E-5
92015-1197	F-8	92039-0023	H-6	92055-0196	B-13	92086-1075	E-5	92145-0724	G-8	92152-0740	E-4
92015-1233	G-7	92039-0068	C-9	92055-086	B-9	92092-0021	E-4	92145-0813	E-11	92152-0748	E-14
92015-1311	B-10	92039-1283	E-10	92055-1011	C-7	92093-0046	B-6	92145-1319	E-8	92152-0751	E-14
92015-1476	D-3	92039-1283	G-3	92055-1155	D-4	92093-0142	B-6	92150-1114	E-8	92152-0767	F-9
92015-1487	D-5	92042-007	B-3	92055-1251	F-6	92093-1030	F-10	92150-1186	D-5	92152-0811	E-7
92015-1528	F-4	92042-014	C-12	92055-1276	D-3	92093-1472	F-9	92150-1301	C-6	92152-0910	G-5
92015-1555	B-12	92043-0026	E-8	92055-1321	F-9	92104-0004	G-9	92150-1340	D-6	92152-0946	E-13
92015-1724	E-6	92043-0182	F-6	92055-1354	C-12	92104-1064	G-9	92150-1433	C-13	92152-1075	C-3
92015-1759	E-6	92043-1037	C-4	92055-1370	D-3	92106-1001	G-9	92150-1604	F-8	92153-0339	B-3
92015-1959	E-6	92043-1263	C-7	92055-1381	D-3	92107-005	G-9	92150-1633	G-5	92153-0474	E-3
92015-1962	F-8	92043-1489	F-5	92055-1563	E-7	92107-1053	G-9	92150-1689	D-5	92153-0506	F-9
92022-077	D-4	92043-1489	F-7	92055-1600	B-3	92110-1015	G-9	92150-1771	F-5	92153-0530	C-4
92022-1088	F-8	92043-1567	B-3	92055-1622	C-9	92110-1132	G-9	92150-1771	F-7	92153-0587	F-5
92022-1298	F-9	92043-1567	B-5	92057-0098	C-12	92110-1144	G-9	92150-1884	C-7	92153-0627	F-4
92022-1401	B-5	92043-1595	E-8	92057-0100	B-9	92110-1147	G-9	92151-1131	C-7	92153-0627	F-6
92022-1405	F-12	92043-4009	B-4	92057-0163	E-14	92110-1148	G-9	92151-1131	D-4	92153-0628	F-4
92022-1496	C-3	92045-0017	E-6	92058-0018	E-14	92110-1152	G-9	92151-1133	D-4	92153-0725	F-6
92022-1601	F-6	92045-0042	B-13	92062-1086	C-4	92110-1153	G-9	92151-1135	C-7	92153-0759	B-6
92022-1827	C-12	92045-1122	B-14	92065-097	C-8	92110-3703	G-9	92151-1149	E-6	92153-0793	B-4
92022-1827	C-3	92045-1224	B-13	92066-0002	B-3	92111-1051	G-9	92151-1152	B-3	92153-0816	H-7
92022-1868	B-12	92045-1235	B-12	92066-0003	C-4	92112-1001	G-9	92151-1226	C-3	92153-0823	E-4
92022-228	F-3	92045-1384	E-3	92066-0032	F-9	92127-003	G-9	92151-1289	F-7	92153-0951	C-13
92022-326	F-3	92046-0008	E-6	92066-0056	C-4	92139-0106	B-12	92151-1305	C-7	92153-0952	C-12
92025-1455	B-13	92046-0017	C-4	92066-0061	C-4	92139-0107	B-13	92151-1357	F-9	92153-0957	B-10
92026-022	B-12	92046-1010	C-7	92066-0071	E-3	92139-0108	B-13	92151-1389	C-4	92153-0958	B-14
92026-087	D-3	92046-1148	C-4	92066-0127	B-6	92139-0114	B-10	92151-1389	C-8	92153-0959	C-6
92026-1217	C-3	92046-1148	C-7	92066-0131	C-7	92139-0115	B-10	92151-1461	C-6	92153-0960	C-6
92026-1529	B-13	92046-1185	B-13	92066-1174	C-8	92139-0116	B-10	92151-1462	C-6	92153-0962	C-4
92027-1450	E-5	92046-1272	E-7	92069-0024	G-6	92139-0117	B-11	92151-1463	C-6	92153-0963	C-4
92027-1653	B-7	92049-0073	F-9	92069-0034	G-4	92139-0118	B-11	92151-1464	C-6	92153-0964	C-4

This catalog covers:

'09~'11 ER650 C9F/CAF/CBF

GRID NO.

L-16

This grid covers:

Numerical Parts Index

Part No.	Grid No.	Part No.	Grid No.	Part No.	Grid No.	Part No.	Grid No.	Part No.	Grid No.	Part No.	Grid No.
92153-0967	G-8	92161-0301	D-5	92172-0209	B-14	92200-0221	B-13	99976-1427	H-8		
92153-0972	B-3	92161-0302	B-6	92172-0298	B-6	92200-0222	B-13	99976-1563	H-8		
92153-0995	E-4	92161-0303	E-14	92172-0320	F-4	92200-0274	C-14	99976-1564	H-8		
92153-1011	B-5	92161-0309	B-6	92172-0343	G-5	92200-0284	G-5	99976-1580	H-8		
92153-1295	C-10	92161-0354	F-12	92172-0395	G-6	92200-0291	B-13	99976-1581	H-8		
92153-1321	B-3	92161-0620	H-6	92172-0427	E-9	92200-0296	E-14	99986-1450	H-8		
92153-1394	B-9	92161-0624	G-3	92172-0427	G-5	92200-0363	B-3	99986-1555	H-8		
92153-1414	C-13	92161-0625	G-3	92172-0427	G-6	92200-0363	B-5	99986-1577	H-8		
92153-1414	C-4	92161-0630	C-11	92172-0473	E-8	92200-0430	E-10	99999-0143	C-9		
92153-1428	E-4	92161-0663	E-5	92173-0001	B-6	92200-0432	E-7	99999-0271	C-9		
92153-1446	F-13	92161-0670	E-8	92173-0005	F-13	92200-0484	E-7				
92153-1449	C-6	92161-0671	E-8	92173-0059	C-4	92200-0506	B-13				
92153-1450	C-6	92161-0726	G-3	92173-0110	B-7	92200-0519	E-7				
92153-1472	F-9	92161-0731	E-8	92173-0288	C-9	92200-1063	C-6				
92153-1517	E-5	92161-0765	G-3	92180-1014	B-8	92200-1240	B-13				
92153-1616	F-10	92161-0773	E-10	92180-1016	B-8	92200-1278	B-13				
92153-1624	F-6	92161-0776	G-5	92180-1018	B-8	92200-1302	F-9				
92153-1630	E-8	92161-0792	H-6	92180-1020	B-8	92200-1388	E-10				
92153-1766	E-7	92161-0821	G-3	92180-1022	B-8	92200-1388	E-9				
92153-1783	D-3	92161-0839	C-11	92180-1024	B-8	92200-1388	H-7				
92153-1985	E-7	92161-1300	C-3	92180-1026	B-8	92200-1480	E-9				
92154-0079	B-12	92161-1321	F-11	92180-1028	B-8	92200-1480	G-3				
92154-0083	E-4	92170-1017	B-6	92180-1030	B-8	92200-1487	B-12				
92154-0115	C-4	92170-1091	F-6	92180-1032	B-8	92210-0007	G-8				
92154-0116	B-3	92170-1114	C-9	92180-1034	B-8	92210-0188	D-3				
92154-0116	B-5	92170-1167	C-4	92180-1036	B-8	92210-0222	B-13				
92154-0117	B-9	92170-1925	F-10	92180-1038	B-8	92210-0223	B-5				
92154-0118	D-6	92171-0069	G-7	92180-1040	B-8	92210-0276	E-14				
92154-0138	E-4	92171-0261	D-6	92180-1042	B-8	92210-0300	E-7				
92154-0139	E-10	92171-0314	B-6	92180-1044	B-8	92210-0474	F-6				
92154-0182	E-10	92171-0337	D-6	92180-1046	B-8	92210-0498	E-10				
92154-0182	E-8	92171-0463	F-6	92180-1048	B-8	92210-0534	E-3				
92154-0187	C-14	92171-0640	G-7	92180-1050	B-8	92210-0535	E-3				
92154-0188	C-12	92171-0652	G-7	92180-1052	B-8	92210-1081	E-4				
92154-0189	B-7	92171-0789	B-4	92180-1054	B-8	92210-1114	B-7				
92154-0235	C-3	92171-0813	B-4	92192-0225	C-4	92210-1352	E-9				
92154-0259	E-5	92171-0836	C-14	92192-0232	B-6	92210-1397	E-6				
92154-0296	F-9	92171-0955	F-6	92192-0679	D-6	99901-0014-01	H-8				
92154-0437	E-11	92171-1089	B-3	92192-0680	B-6	99903-0014-01	H-8				
92154-0440	F-8	92171-1415	G-7	92192-0700	E-11	99924-1418-02	H-8				
92160-1116	B-7	92171-1424	G-7	92192-0709	B-6	99931-1506-01	H-8				
92160-1161	E-7	92171-1559	G-7	92192-0733	F-10	99946-1054-01	H-8				
92160-1162	G-4	92171-1584	B-6	92192-0818	B-6	99950-1061-01	H-8				
92160-1167	F-12	92171-1873	C-7	92200-0036	E-3	99951-1043-01	H-8				
92160-1613	F-14	92171-1887	F-4	92200-0043	E-8	99952-1030-01	H-8				
92160-1613	G-3	92171-1897	G-7	92200-0081	E-3	99953-1049-02	H-8				
92160-1613	H-7	92171-1973	F-10	92200-0115	C-6	99954-1063-02	H-8				
92161-0037	F-8	92171-1992	D-6	92200-0164	G-6	99955-1041-02	H-8				
92161-0163	G-5	92172-0064	C-9	92200-0165	G-6	99956-1027-02	H-8				
92161-0267	C-4	92172-0183	F-8	92200-0220	C-13	99976-1426	H-8				

This catalog covers:

'09~'11 ER650 C9F/CAF/CBF

GRID NO.

B-16

This grid covers:

Part Name Index

Air Cleaner.....	B-6
Balancer.....	B-11
Brake Pedal.....	F-3
Cables.....	F-13
Camshaft(s).....	B-9
Chain Cover.....	F-14
Chassis Electrical Equipment.....	G-7
Clutch.....	B-12
Cowling.....	H-6
Crankcase.....	C-4/C-5
Crankcase Bolt Pattern.....	C-6
Crankshaft.....	B-10
Cylinder.....	B-5
Cylinder Head.....	B-3
Cylinder Head Cover.....	B-4
Decals(C.B.Orange)(P.S.White)(C9F).....	G-11
Decals(Ebony)(CAF).....	G-13
Decals(L.Green)(CAF).....	H-3
Decals(M.D.Black)(C9F).....	G-12
Decals(M.F.S.Green)(CBF).....	H-4
Decals(M.S.Black)(CBF).....	H-5
Decals(Orange)(CAF)(P.White)(CBF).....	G-14
Engine Cover(s).....	C-7
Engine Mount.....	E-4
Footrests.....	E-8
Frame.....	E-3
Frame Fittings.....	E-5
Front Brake.....	F-5
Front Fender(s).....	E-9
Front Fork.....	F-9
Front Hub.....	E-13
Front Master Cylinder.....	F-4
Fuel Injection.....	C-11
Fuel Pump.....	C-10
Fuel Tank.....	F-10
Gear Change Drum.....	B-14
Gear Change Mechanism.....	C-3

Generator.....	C-13
Handlebar.....	F-8
Headlight(s).....	G-4
Ignition Switch.....	G-8
Ignition System.....	C-14
Labels.....	G-10
Manual.....	H-8
Meter(s).....	F-12
Muffler(s).....	B-7
Oil Pan.....	C-8
Oil Pump.....	C-12
Owner's Tools.....	G-9
Piston(s).....	B-5
Radiator.....	D-5
Rear Brake.....	F-7
Rear Fender(s).....	E-10
Rear Hub.....	E-14
Rear Master Cylinder.....	F-6
Seat.....	F-11
Seat Cover.....	G-3
Shift Fork(s).....	B-14
Shock Absorber.....	E-7
Shroud.....	H-7
Side Covers.....	F-14
Stand(s).....	E-11
Starter Motor.....	D-3
Suspension.....	E-7
Swingarm.....	E-6
Taillight(s).....	G-5
Tensioner.....	B-9
Throttle.....	C-9
Tires.....	E-12
Transmission.....	B-13
Turn Signals.....	G-6
Valve(s).....	B-8
Water Pipe.....	D-6
Water Pump.....	D-4

This catalog covers:

'09~'11 ER650 C9F/CAF/CBF

GRID NO.

C-16

This grid covers:

Part Name Index

Air Cleaner.....	B-6
Balancer.....	B-11
Brake Pedal.....	F-3
Cables.....	F-13
Camshaft(s).....	B-9
Chain Cover.....	F-14
Chassis Electrical Equipment.....	G-7
Clutch.....	B-12
Cowling.....	H-6
Crankcase.....	C-4/C-5
Crankcase Bolt Pattern.....	C-6
Crankshaft.....	B-10
Cylinder.....	B-5
Cylinder Head.....	B-3
Cylinder Head Cover.....	B-4
Decals(C.B.Orange)(P.S.White)(C9F).....	G-11
Decals(Ebony)(CAF).....	G-13
Decals(L.Green)(CAF).....	H-3
Decals(M.D.Black)(C9F).....	G-12
Decals(M.F.S.Green)(CBF).....	H-4
Decals(M.S.Black)(CBF).....	H-5
Decals(Orange)(CAF)(P.White)(CBF).....	G-14
Engine Cover(s).....	C-7
Engine Mount.....	E-4
Footrests.....	E-8
Frame.....	E-3
Frame Fittings.....	E-5
Front Brake.....	F-5
Front Fender(s).....	E-9
Front Fork.....	F-9
Front Hub.....	E-13
Front Master Cylinder.....	F-4
Fuel Injection.....	C-11
Fuel Pump.....	C-10
Fuel Tank.....	F-10
Gear Change Drum.....	B-14
Gear Change Mechanism.....	C-3

Generator.....	C-13
Handlebar.....	F-8
Headlight(s).....	G-4
Ignition Switch.....	G-8
Ignition System.....	C-14
Labels.....	G-10
Manual.....	H-8
Meter(s).....	F-12
Muffler(s).....	B-7
Oil Pan.....	C-8
Oil Pump.....	C-12
Owner's Tools.....	G-9
Piston(s).....	B-5
Radiator.....	D-5
Rear Brake.....	F-7
Rear Fender(s).....	E-10
Rear Hub.....	E-14
Rear Master Cylinder.....	F-6
Seat.....	F-11
Seat Cover.....	G-3
Shift Fork(s).....	B-14
Shock Absorber.....	E-7
Shroud.....	H-7
Side Covers.....	F-14
Stand(s).....	E-11
Starter Motor.....	D-3
Suspension.....	E-7
Swingarm.....	E-6
Taillight(s).....	G-5
Tensioner.....	B-9
Throttle.....	C-9
Tires.....	E-12
Transmission.....	B-13
Turn Signals.....	G-6
Valve(s).....	B-8
Water Pipe.....	D-6
Water Pump.....	D-4

This catalog covers:

'09~'11 ER650 C9F/CAF/CBF

GRID NO.

D-16

This grid covers:

Part Name Index

Air Cleaner.....	B-6
Balancer.....	B-11
Brake Pedal.....	F-3
Cables.....	F-13
Camshaft(s).....	B-9
Chain Cover.....	F-14
Chassis Electrical Equipment.....	G-7
Clutch.....	B-12
Cowling.....	H-6
Crankcase.....	C-4/C-5
Crankcase Bolt Pattern.....	C-6
Crankshaft.....	B-10
Cylinder.....	B-5
Cylinder Head.....	B-3
Cylinder Head Cover.....	B-4
Decals(C.B.Orange)(P.S.White)(C9F).....	G-11
Decals(Ebony)(CAF).....	G-13
Decals(L.Green)(CAF).....	H-3
Decals(M.D.Black)(C9F).....	G-12
Decals(M.F.S.Green)(CBF).....	H-4
Decals(M.S.Black)(CBF).....	H-5
Decals(Orange)(CAF)(P.White)(CBF).....	G-14
Engine Cover(s).....	C-7
Engine Mount.....	E-4
Footrests.....	E-8
Frame.....	E-3
Frame Fittings.....	E-5
Front Brake.....	F-5
Front Fender(s).....	E-9
Front Fork.....	F-9
Front Hub.....	E-13
Front Master Cylinder.....	F-4
Fuel Injection.....	C-11
Fuel Pump.....	C-10
Fuel Tank.....	F-10
Gear Change Drum.....	B-14
Gear Change Mechanism.....	C-3

Generator.....	C-13
Handlebar.....	F-8
Headlight(s).....	G-4
Ignition Switch.....	G-8
Ignition System.....	C-14
Labels.....	G-10
Manual.....	H-8
Meter(s).....	F-12
Muffler(s).....	B-7
Oil Pan.....	C-8
Oil Pump.....	C-12
Owner's Tools.....	G-9
Piston(s).....	B-5
Radiator.....	D-5
Rear Brake.....	F-7
Rear Fender(s).....	E-10
Rear Hub.....	E-14
Rear Master Cylinder.....	F-6
Seat.....	F-11
Seat Cover.....	G-3
Shift Fork(s).....	B-14
Shock Absorber.....	E-7
Shroud.....	H-7
Side Covers.....	F-14
Stand(s).....	E-11
Starter Motor.....	D-3
Suspension.....	E-7
Swingarm.....	E-6
Taillight(s).....	G-5
Tensioner.....	B-9
Throttle.....	C-9
Tires.....	E-12
Transmission.....	B-13
Turn Signals.....	G-6
Valve(s).....	B-8
Water Pipe.....	D-6
Water Pump.....	D-4

This catalog covers:

'09~'11 ER650 C9F/CAF/CBF

GRID NO.

E-16

This grid covers:

Part Name Index

Air Cleaner.....	B-6
Balancer.....	B-11
Brake Pedal.....	F-3
Cables.....	F-13
Camshaft(s).....	B-9
Chain Cover.....	F-14
Chassis Electrical Equipment.....	G-7
Clutch.....	B-12
Cowling.....	H-6
Crankcase.....	C-4/C-5
Crankcase Bolt Pattern.....	C-6
Crankshaft.....	B-10
Cylinder.....	B-5
Cylinder Head.....	B-3
Cylinder Head Cover.....	B-4
Decals(C.B.Orange)(P.S.White)(C9F).....	G-11
Decals(Ebony)(CAF).....	G-13
Decals(L.Green)(CAF).....	H-3
Decals(M.D.Black)(C9F).....	G-12
Decals(M.F.S.Green)(CBF).....	H-4
Decals(M.S.Black)(CBF).....	H-5
Decals(Orange)(CAF)(P.White)(CBF).....	G-14
Engine Cover(s).....	C-7
Engine Mount.....	E-4
Footrests.....	E-8
Frame.....	E-3
Frame Fittings.....	E-5
Front Brake.....	F-5
Front Fender(s).....	E-9
Front Fork.....	F-9
Front Hub.....	E-13
Front Master Cylinder.....	F-4
Fuel Injection.....	C-11
Fuel Pump.....	C-10
Fuel Tank.....	F-10
Gear Change Drum.....	B-14
Gear Change Mechanism.....	C-3

Generator.....	C-13
Handlebar.....	F-8
Headlight(s).....	G-4
Ignition Switch.....	G-8
Ignition System.....	C-14
Labels.....	G-10
Manual.....	H-8
Meter(s).....	F-12
Muffler(s).....	B-7
Oil Pan.....	C-8
Oil Pump.....	C-12
Owner's Tools.....	G-9
Piston(s).....	B-5
Radiator.....	D-5
Rear Brake.....	F-7
Rear Fender(s).....	E-10
Rear Hub.....	E-14
Rear Master Cylinder.....	F-6
Seat.....	F-11
Seat Cover.....	G-3
Shift Fork(s).....	B-14
Shock Absorber.....	E-7
Shroud.....	H-7
Side Covers.....	F-14
Stand(s).....	E-11
Starter Motor.....	D-3
Suspension.....	E-7
Swingarm.....	E-6
Taillight(s).....	G-5
Tensioner.....	B-9
Throttle.....	C-9
Tires.....	E-12
Transmission.....	B-13
Turn Signals.....	G-6
Valve(s).....	B-8
Water Pipe.....	D-6
Water Pump.....	D-4

This catalog covers:

'09~'11 ER650 C9F/CAF/CBF

GRID NO.

F-16

This grid covers:

Part Name Index

Air Cleaner.....	B-6
Balancer.....	B-11
Brake Pedal.....	F-3
Cables.....	F-13
Camshaft(s).....	B-9
Chain Cover.....	F-14
Chassis Electrical Equipment.....	G-7
Clutch.....	B-12
Cowling.....	H-6
Crankcase.....	C-4/C-5
Crankcase Bolt Pattern.....	C-6
Crankshaft.....	B-10
Cylinder.....	B-5
Cylinder Head.....	B-3
Cylinder Head Cover.....	B-4
Decals(C.B.Orange)(P.S.White)(C9F).....	G-11
Decals(Ebony)(CAF).....	G-13
Decals(L.Green)(CAF).....	H-3
Decals(M.D.Black)(C9F).....	G-12
Decals(M.F.S.Green)(CBF).....	H-4
Decals(M.S.Black)(CBF).....	H-5
Decals(Orange)(CAF)(P.White)(CBF).....	G-14
Engine Cover(s).....	C-7
Engine Mount.....	E-4
Footrests.....	E-8
Frame.....	E-3
Frame Fittings.....	E-5
Front Brake.....	F-5
Front Fender(s).....	E-9
Front Fork.....	F-9
Front Hub.....	E-13
Front Master Cylinder.....	F-4
Fuel Injection.....	C-11
Fuel Pump.....	C-10
Fuel Tank.....	F-10
Gear Change Drum.....	B-14
Gear Change Mechanism.....	C-3

Generator.....	C-13
Handlebar.....	F-8
Headlight(s).....	G-4
Ignition Switch.....	G-8
Ignition System.....	C-14
Labels.....	G-10
Manual.....	H-8
Meter(s).....	F-12
Muffler(s).....	B-7
Oil Pan.....	C-8
Oil Pump.....	C-12
Owner's Tools.....	G-9
Piston(s).....	B-5
Radiator.....	D-5
Rear Brake.....	F-7
Rear Fender(s).....	E-10
Rear Hub.....	E-14
Rear Master Cylinder.....	F-6
Seat.....	F-11
Seat Cover.....	G-3
Shift Fork(s).....	B-14
Shock Absorber.....	E-7
Shroud.....	H-7
Side Covers.....	F-14
Stand(s).....	E-11
Starter Motor.....	D-3
Suspension.....	E-7
Swingarm.....	E-6
Taillight(s).....	G-5
Tensioner.....	B-9
Throttle.....	C-9
Tires.....	E-12
Transmission.....	B-13
Turn Signals.....	G-6
Valve(s).....	B-8
Water Pipe.....	D-6
Water Pump.....	D-4

This catalog covers:

'09~'11 ER650 C9F/CAF/CBF

GRID NO.

G-16

This grid covers:

Part Name Index

Air Cleaner.....	B-6
Balancer.....	B-11
Brake Pedal.....	F-3
Cables.....	F-13
Camshaft(s).....	B-9
Chain Cover.....	F-14
Chassis Electrical Equipment.....	G-7
Clutch.....	B-12
Cowling.....	H-6
Crankcase.....	C-4/C-5
Crankcase Bolt Pattern.....	C-6
Crankshaft.....	B-10
Cylinder.....	B-5
Cylinder Head.....	B-3
Cylinder Head Cover.....	B-4
Decals(C.B.Orange)(P.S.White)(C9F).....	G-11
Decals(Ebony)(CAF).....	G-13
Decals(L.Green)(CAF).....	H-3
Decals(M.D.Black)(C9F).....	G-12
Decals(M.F.S.Green)(CBF).....	H-4
Decals(M.S.Black)(CBF).....	H-5
Decals(Orange)(CAF)(P.White)(CBF).....	G-14
Engine Cover(s).....	C-7
Engine Mount.....	E-4
Footrests.....	E-8
Frame.....	E-3
Frame Fittings.....	E-5
Front Brake.....	F-5
Front Fender(s).....	E-9
Front Fork.....	F-9
Front Hub.....	E-13
Front Master Cylinder.....	F-4
Fuel Injection.....	C-11
Fuel Pump.....	C-10
Fuel Tank.....	F-10
Gear Change Drum.....	B-14
Gear Change Mechanism.....	C-3

Generator.....	C-13
Handlebar.....	F-8
Headlight(s).....	G-4
Ignition Switch.....	G-8
Ignition System.....	C-14
Labels.....	G-10
Manual.....	H-8
Meter(s).....	F-12
Muffler(s).....	B-7
Oil Pan.....	C-8
Oil Pump.....	C-12
Owner's Tools.....	G-9
Piston(s).....	B-5
Radiator.....	D-5
Rear Brake.....	F-7
Rear Fender(s).....	E-10
Rear Hub.....	E-14
Rear Master Cylinder.....	F-6
Seat.....	F-11
Seat Cover.....	G-3
Shift Fork(s).....	B-14
Shock Absorber.....	E-7
Shroud.....	H-7
Side Covers.....	F-14
Stand(s).....	E-11
Starter Motor.....	D-3
Suspension.....	E-7
Swingarm.....	E-6
Taillight(s).....	G-5
Tensioner.....	B-9
Throttle.....	C-9
Tires.....	E-12
Transmission.....	B-13
Turn Signals.....	G-6
Valve(s).....	B-8
Water Pipe.....	D-6
Water Pump.....	D-4

This catalog covers:

'09~'11 ER650 C9F/CAF/CBF

GRID NO.

H-16

This grid covers:

Part Name Index

Air Cleaner.....	B-6
Balancer.....	B-11
Brake Pedal.....	F-3
Cables.....	F-13
Camshaft(s).....	B-9
Chain Cover.....	F-14
Chassis Electrical Equipment.....	G-7
Clutch.....	B-12
Cowling.....	H-6
Crankcase.....	C-4/C-5
Crankcase Bolt Pattern.....	C-6
Crankshaft.....	B-10
Cylinder.....	B-5
Cylinder Head.....	B-3
Cylinder Head Cover.....	B-4
Decals(C.B.Orange)(P.S.White)(C9F).....	G-11
Decals(Ebony)(CAF).....	G-13
Decals(L.Green)(CAF).....	H-3
Decals(M.D.Black)(C9F).....	G-12
Decals(M.F.S.Green)(CBF).....	H-4
Decals(M.S.Black)(CBF).....	H-5
Decals(Orange)(CAF)(P.White)(CBF).....	G-14
Engine Cover(s).....	C-7
Engine Mount.....	E-4
Footrests.....	E-8
Frame.....	E-3
Frame Fittings.....	E-5
Front Brake.....	F-5
Front Fender(s).....	E-9
Front Fork.....	F-9
Front Hub.....	E-13
Front Master Cylinder.....	F-4
Fuel Injection.....	C-11
Fuel Pump.....	C-10
Fuel Tank.....	F-10
Gear Change Drum.....	B-14
Gear Change Mechanism.....	C-3

Generator.....	C-13
Handlebar.....	F-8
Headlight(s).....	G-4
Ignition Switch.....	G-8
Ignition System.....	C-14
Labels.....	G-10
Manual.....	H-8
Meter(s).....	F-12
Muffler(s).....	B-7
Oil Pan.....	C-8
Oil Pump.....	C-12
Owner's Tools.....	G-9
Piston(s).....	B-5
Radiator.....	D-5
Rear Brake.....	F-7
Rear Fender(s).....	E-10
Rear Hub.....	E-14
Rear Master Cylinder.....	F-6
Seat.....	F-11
Seat Cover.....	G-3
Shift Fork(s).....	B-14
Shock Absorber.....	E-7
Shroud.....	H-7
Side Covers.....	F-14
Stand(s).....	E-11
Starter Motor.....	D-3
Suspension.....	E-7
Swingarm.....	E-6
Taillight(s).....	G-5
Tensioner.....	B-9
Throttle.....	C-9
Tires.....	E-12
Transmission.....	B-13
Turn Signals.....	G-6
Valve(s).....	B-8
Water Pipe.....	D-6
Water Pump.....	D-4